



MERCURY

ELECTRONIC

瑪居禮電波

MERCURY ELECTRONIC

2025_A Catalog

Crystal Oscillators
Crystal Units / Crystal Filters
Frequency Control Products

Contents

Mercury company profile	1
How to specify Mercury products	[Crystal Unit]	2
	[Clock Oscillators]	3
	[Spread Spectrum Low EMI Oscillator]	4
	[VCXO]	5
	[VC / TCXO]	6
	[OCXO]	7
	[M.C.F.]	8

Specifications

Crystal Units

SMD --- Ceramic Leadless	9 ~ 10
SMD --- Metal Housing Gull wing	11
Thru - Hole --- Metal Housing Type	12 ~ 13
32.768 KHz SMD --- Ceramic Leadless , Dip --- Tuning fork Crystal	14

Clock Oscillators [Product Code " H " Including CMOS , Differential Type : (LVPECL , LVDS , HCSSL , LPHCSL and CML) Output]

	SMD --- Ceramic Type [50 KHz ~ 160.0 MHz] --- SWO , H53 , H32 , H22 and H21_ series	16
	Dip --- Thru - Hole Type [H8 , H14_ series] , 50 KHz ~ 160.0 MHz	17
	(uA low current , 32.768 KHz , 27.3 ~ 100.0 KHz) Clock Oscillators [AT-cut crystal for it's high frequency stability] --- HA_ series	18
	(uA low current , 32.768 KHz) Clock Oscillators [AT-cut crystal for it's high frequency stability] --- HEA_ series	19
	(Low 1.0V to 1.2V supply voltage) Clock Oscillators [0.625 MHz ~ 50 MHz] --- HU_ series	20
	(Wide Operating Temperature) Clock Oscillators [Over - 40 °C to +125 °C] --- HY_ series	21
CMOS	(Ultra Low Jitter) Clock Oscillators [57 fsec (typ.) @ 3.3V , 49.152 MHz] , 0.625 MHz ~ 50 MHz --- HJN_ series	24 ~ 25
	(Quick Turn) (Low Jitter) Clock Oscillators [1.0 MHz ~ 200 MHz] --- HTF_ series	26 ~ 27
	(Low Phase Jitter , High Frequency Range) Clock Oscillators [50 MHz ~ 250 MHz , 0.6 ps (typ.)] --- HTQN_ series	34 ~ 35
	(Quick Turn) (High Frequency Range) Clock Oscillators [10 MHz ~ 250 MHz , 0.8 ps (typ.)] --- HTQF_ series	36 ~ 37
	(Ultra Low Jitter) Clock Oscillators [RMS Jitter 150 fsec] , 50 MHz ~ 250 MHz --- HTJFN_ series	38 ~ 40
	(Spread Spectrum Low EMI) Clock Oscillators , B types , 3 MHz ~ 200 MHz --- HMB_ series	42
	(Spread Spectrum Low EMI) Clock Oscillators , C types , 16 MHz ~ 40 MHz --- HMC_ series	43
	(Dual Frequencies Switchable) Clock Oscillators [Select f1 or f2 by Toggling Pin 2] , 10 MHz ~ 250 MHz --- HCTQF_ series	45 ~ 46
	(4 Frequencies Switchable) Clock Oscillators [150fs RMS Jitter typ.] --- HCTJFN578_ series	47 ~ 48
	LVPECL	(Non - PLL) [Frequency Range: 13.5 MHz ~ 200 MHz] --- HPK_ series
(Non - PLL) [Frequency Range: 10 MHz ~ 250 MHz] --- HPRK_ series		32 ~ 33
(Superb phase noise) Differential Oscillator [RMS Jitter 98 fsec. (typ.)] , 13.5 MHz ~ 220 MHz --- HPEK_ series		29
(Ultra Low Jitter) Differential Oscillator [RMS Jitter 50 fsec. (typ.)] , 100 MHz ~ 250 MHz --- HPJK_ series		30
(Low Phase Jitter , High Frequency Range) [50 MHz ~ 1,500 MHz , 0.6 ps (typ.)] --- HPQN_ series		34 ~ 35
(Quick Turn) (High Frequency Range) Clock Oscillators [10 MHz ~ 1,500 MHz , 0.8 ps (typ.)] --- HPQF_ series		36 ~ 37
(Ultra Low Jitter) (High Frequency Range) Clock Oscillators [RMS Jitter 150 fsec] , 50 MHz ~ 2,100 MHz --- HPJFN_ series		38 ~ 40
(Dual Frequencies Switchable) Clock Oscillators [Select f1 or f2 by Toggling Pin 2] , 10 MHz ~ 1,500 MHz --- HCPQF_ series		45 ~ 46
LVDS	(4 Frequencies Switchable) Clock Oscillators [150fs RMS Jitter typ.] --- HCPJFN578_ series	47 ~ 48
	(Non - PLL) [Frequency Range: 13.5 MHz ~ 200 MHz] --- HDK_ series	28
	(Non - PLL) [Frequency Range: 10 MHz ~ 250 MHz] --- HDRK_ series	32 ~ 33
	(Superb phase noise) Differential Oscillator [RMS Jitter 98 fsec. (typ.)] , 13.5 MHz ~ 220 MHz --- HDEK_ series	29
	(Ultra Low Jitter) Differential Oscillator [RMS Jitter 50 fsec. (typ.)] , 100 MHz ~ 250 MHz --- HDJK_ series	30
	(Low Phase Jitter , High Frequency Range) Clock Oscillators [50 MHz ~ 1,500 MHz , 0.6 ps (typ.)] --- HDQN_ series	34 ~ 35
	(Quick Turn) (High Frequency Range) Clock Oscillators [10 MHz ~ 1,500 MHz , 0.8 ps (typ.)] --- HDQF_ series	36 ~ 37
	(Ultra Low Jitter) (High Frequency Range) Clock Oscillators [RMS Jitter 150 fsec] , 15 MHz ~ 2,100 MHz --- HDJFN_ series	38 ~ 40
HCSSL	(Dual Frequencies Switchable) Clock Oscillators [Select f1 or f2 by Toggling Pin 2] , 10 MHz ~ 1,500 MHz --- HCDQF_ series	45 ~ 46
	(4 Frequencies Switchable) Clock Oscillators [150fs RMS Jitter typ.] --- HCDJFN578_ series	47 ~ 48
	(Non - PLL) [Frequency Range: 13.5 MHz ~ 200 MHz] --- HCK_ series	28
	(Non - PLL) [Frequency Range: 10 MHz ~ 250 MHz] --- HCRK_ series	32 ~ 33
	(Superb phase noise) Differential Oscillator [RMS Jitter 98 fsec. (typ.)] , 13.5 MHz ~ 220 MHz --- HCEK_ series	29
LPHCSL	(Ultra Low Jitter) Differential Oscillator [RMS Jitter 50 fsec. (typ.)] , 100 MHz ~ 250 MHz --- HCJK_ series	30
	(Ultra Low Jitter) (High Frequency Range) Clock Oscillators [RMS Jitter 150 fsec] , 50 MHz ~ 700MHz --- HCJFN_ series	38 ~ 40
	(4 Frequencies Switchable) Clock Oscillators [150 fs RMS Jitter typ.] --- HCCJFN578_ series	47 ~ 48
CML	(Low Power HCSSL) [Frequency Range: 95 MHz ~ 180 MHz] --- HCLK_ series	28
	(Ultra Low Jitter) (High Frequency Range) Clock Oscillators [RMS Jitter 150 fsec] , 50 MHz ~ 2,100MHz --- HQJFN_ series	38 ~ 40
	(4 Frequencies Switchable) Clock Oscillators [150fs RMS Jitter typ.] --- HCQJFN578_ series	47 ~ 48
True Sine	True Sine Wave Clock Oscillators (50 ohm load) --- HS_ series	49 ~ 50

Contents

VCXOs (Voltage Controlled Crystal Oscillators) [product code " G "]		51
CMOS	1.25 MHz ~ 50 MHz VCXO --- G_series 52 ~ 54	
	(Low Phase Jitter , High Frequency Range) [10 MHz ~ 250 MHz , 0.6 ps (typ.)] --- GTQN_series 55	
	(Quick Turn) (High Frequency Range) VCXO [10 MHz ~ 250 MHz , 1.2 ps (typ.)] --- GTQF_series 56	
	(Dual Frequencies Switchable) Clock Oscillators [Select f1 or f2 by Toggling Pin 2] --- GCTQF_series 58 ~ 59	
	(Ultra Low Jitter) VCXO [RMS Jitter 150 fsec] , 15 MHz ~ 250 MHz --- GTJFN_series 60 ~ 61	
LVPECL	(Low Phase Jitter , High Frequency Range) [10 MHz ~ 1,500 MHz , 0.6 ps (typ.)] --- GPQN_series 55	
	(Quick Turn) (High Frequency Range) VCXO [10 MHz ~ 1,500 MHz , 1.2 ps (typ.)] --- GPQF_series 56	
	(Dual Frequencies Switchable) Clock Oscillators [Select f1 or f2 by Toggling Pin 2] --- GCPQF_series 58 ~ 59	
	(Ultra Low Jitter) (High Frequency Range) Clock Oscillators [RMS Jitter 150 fsec] , 15 MHz ~ 2,100 MHz --- GPJFN_series 60 ~ 61	
LVDS	(Low Phase Jitter , High Frequency Range) [10 MHz ~ 1,500 MHz , 0.6 ps (typ.)] --- GDQN_series 55	
	(Quick Turn) (High Frequency Range) VCXO [10 MHz ~ 1,500 MHz , 1.2 ps (typ.)] --- GDQF_series 56	
	(Dual Frequencies Switchable) Clock Oscillators [Select f1 or f2 by Toggling Pin 2] --- GCDQF_series 58 ~ 59	
	(Ultra Low Jitter) (High Frequency Range) Clock Oscillators [RMS Jitter 150 fsec] , 15 MHz ~ 2,100 MHz --- GDJFN_series 60 ~ 61	
HCSL	(Ultra Low Jitter) (High Frequency Range) Clock Oscillators [RMS Jitter 150 fsec] , 15 MHz ~ 700 MHz --- GCJFN_series 60 ~ 61	
CML	(Ultra Low Jitter) (High Frequency Range) Clock Oscillators [RMS Jitter 150 fsec] , 15 MHz ~ 2,100 MHz --- GQJFN_series 60 ~ 61	
TCXOs (Temperature Compensated Crystal Oscillators) [product code " M "] VCTCXOs (Voltage Controlled TCXOs) [product code " VM "]		62 , 68
Clipped Sine	SMD (VC)TCXO --- Ceramic Leadless [6.4 MHz ~ 52.0 MHz] --- (V) M__S__series 63 ~ 64	
	Dip TCXO --- Thru - Hole Type [6.4 MHz ~ 52.0 MHz] --- (V) M__S__series 65 ~ 66	
CMOS	KHz range (VC)TCXO (15pF) --- [20.0 KHz ~ 52.7 KHz , 32.768 KHz] --- (V)M__T__series 69 ~ 70	
	MHz range (VC)TCXO (15pF) --- [6.4 MHz ~ 52.0 MHz] --- (V)M__T__series 71 ~ 75	
	32.768 KHz TCXO [uA Current Consumption] --- ME21T / ME32T_series 76 ~ 77	
	(High Frequency Range) (VC)TCXO [10 MHz ~ 250 MHz , 0.8 ps (typ.)] --- (V)MQN__T__series 78	
	(Quick Turn) (High Frequency Range) TCXO [10 MHz ~ 250 MHz , 1.0 ps (typ.)] --- (V)MQF__T__series 79	
	Miniature CMOS TCXO [Frequency Range: 9.5 MHz ~ 60 MHz] --- M__1T__series 83 ~ 84	
	Programmable low cost CMOS TCXO [Frequency Range: 1.0 MHz ~ 200 MHz] --- (V) MTF__T__series 85 ~ 86	
LVPECL	(High Frequency Range) (VC)TCXO [10 MHz ~ 1,500 MHz , 0.8 ps (typ.)] --- (V)MQN__P__series 78	
	(Quick Turn) (High Frequency Range) TCXO [10 MHz ~ 1,500 MHz , 1.0 ps (typ.)] --- (V)MQF__P__series 79	
	(Ultra Low Jitter) (High Frequency Range) , 15 MHz ~ 2,100MHz --- (V)MJF326P , (V)MJF538P_series: 81 ~ 82	
LVDS	(High Frequency Range) (VC)TCXO [10 MHz ~ 1,500 MHz , 0.8 ps (typ.)] --- (V)MQN__D__series 78	
	(Quick Turn) (High Frequency Range) TCXO [10 MHz ~ 1,500 MHz , 1.0 ps (typ.)] --- (V)MQF__D__series 79	
	(Ultra Low Jitter) (High Frequency Range) , 15 MHz ~ 2,100MHz --- (V)MJF326D , (V)MJF538D_series 81 ~ 82	
HCSL	(Ultra Low Jitter) (High Frequency Range) , 15 MHz ~ 700MHz --- (V)MJF326C , (V)MJF538C_series 81 ~ 82	
CML	(Ultra Low Jitter) (High Frequency Range) , 15 MHz ~ 2,100MHz --- (V)MJF326Q , (V)MJF538Q_serie 81 ~ 82	
OCXOs (Oven Controlled Crystal Oscillators) [product code " OC "]		87
	SMD - Ceramic Type --- OC12 , OC41 , OC51 88 , 93 ~ 94	
	Thru - Hole Metal - can Type --- OC13 , OC14 , OC18 , OC19 , OC32 89 ~ 92	
M. C. F. (Monolithic Crystal Filters)		96
	SMD - Ceramic Type 97	
	Thru - Hole --- Metal - can Type 98 ~ 100	
	Part Number Formats and Product Marking Rules 101 ~ 110	
	Embossed Tape and Reel Specifications 111 ~ 113	



MERCURY

ELECTRONIC

瑪居禮電波

Mercury Company Profile

Taiwan Plant

Mercury Electronic Ind. Co., Ltd
瑪居禮電波工業股份有限公司

台灣新北市瑞芳區瑞芳工業區頂坪路31號

No. 31, Ting Ping Rd., Shui-Fong Ind. Park, Shui-Fong District, New Taipei City, Taiwan, 224012

Tel : 886-2-2406-2779

Fax : 886-2-2496-0769

E-mail : sales-tw@mercury-crystal.com

Web site : www.mercury-crystal.com

- Established in 1973 .
- Proud to be a pioneer of the crystal industry in Taiwan .
- Corporate headquarters and volume production facility
- IATF 16949 + ISO9001 and 14001 certified .



Kunshan Office

Mercury Crystal Technology (Kun Shan) Inc.
瑪居禮石英晶體科技 (昆山) 有限公司

中國江蘇省昆山市開發區春旭路258號東安大廈401室

Room 401 Dongan Building Chunxu Road 258 ,

Development Zone Kunshan City

Tel : 86-(512)-5763-8100

Fax : 86-(512)-5763-8103

E-mail : sales-cn@mercury-crystal.com

- Established in 2002.
- The Sales Office.



WeChat



How To Specify A Quartz Crystal

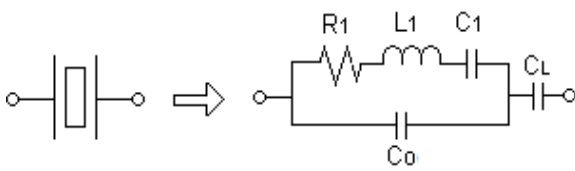

C_0 : Shunt Capacitance
C_1 : Motional Capacitance
L_1 : Motional Inductance
R_1 : Equivalent Series Resistance
C_L : Load Capacitance

Holder Type

SMD Type

unit : mm

unit : mm

<input type="checkbox"/> X11 (1.65*1.25*0.30)	<input type="checkbox"/> MQ (7.0*5.0*1.0)
<input type="checkbox"/> X21 (2.05*1.65*0.50)	<input type="checkbox"/> M49 (12.4*4.5*4.0)
<input type="checkbox"/> X22 (2.55*2.05*0.60)	<input type="checkbox"/> ML49 (12.4*4.5*3.0)
<input type="checkbox"/> X32 (3.2*2.5*0.7)	<input type="checkbox"/> MP4 (12.9*4.5*4.0)
<input type="checkbox"/> MJ (5.0*3.2*0.8)	<input type="checkbox"/> MP5 (12.9*4.5*5.0)
<input type="checkbox"/> X2012 (2.05*1.2*0.55)	<input type="checkbox"/> MP24 (11.4*5.0*4.0)
<input type="checkbox"/> X3215 (3.2*1.5*0.8)	<input type="checkbox"/> MP25 (11.4*5.0*5.0)

Thru - Hole Type

unit : mm

<input type="checkbox"/> H49 (10.7*4.5*13.2)
<input type="checkbox"/> HUS (10.7*4.3*3.5)
<input type="checkbox"/> HUSL (10.7*4.3*4.3)
<input type="checkbox"/> U1 (7.8*3.2*8.0)
<input type="checkbox"/> U5 (7.8*3.2*6.0)
<input type="checkbox"/> T38 (3.0 ϕ *8.0)
<input type="checkbox"/> T26 (2.0 ϕ *6.0)

A Basic Spec. must be specified

- A-1 : Holder type: _____ Thru-Hole type SMD Leadless
- A-2 : Frequency : _____ MHz or _____ KHz
- A-3 : Circuit Condition : Series Parallel
 If **Series** resonance : Assign " **S** " as circuit load .
 If **Parallel** : Specify CL (Load Capacitance) _____ pF (Typical range is 8 to 32 pF) .
- A-4 : Calibration Tolerance: \pm _____ ppm (max.) at 25°C
- A-5 : Frequency Stability: \pm _____ ppm (max.) over _____ °C to _____ °C
- A-6 : Maximum Equivalent Series Resistance (ESR): _____ ohms (max.)

B Other Spec. If not specified MEC standards will be applied.

- B-1 : Shunt Capacitance (Co) : _____ pF (max.)
- B-2 : Motional Capacitance (C1) : _____ fF \pm _____ %
- B-3 : Motional Inductance (L1) : _____ mH \pm _____ %
- B-4 : Capacitance Ratio (Co/C1) : _____ \pm _____ %
- B-5 : Trim Sensitivity : _____ ppm / pF
- B-6 : Frequency Pull Ability : When CL= _____ pF, _____ ppm (max.) ; When CL= _____ pF, _____ ppm (min.)
- B-7 : Drive Level : _____ micro Watts (uW) (max.) .
- B-8 : Crystal cutting angle type : AT - cut SL - cut XT - cut
- B-9 : Mode of Oscillation : Fundamental mode 3rd overtone 5th overtone
- B-10 : Spurious: _____ dB (or ohms) (min.) in \pm _____ kHz range of the main mode
- B-11 : Crystal Q: _____ (min.)
- B-12 : Aging: _____ ppm per year (max.)
- B-13 : Shock: _____ ; Vibration: _____

Part Number Format and Example

Example: X32 - 16.000 - 10 - 15 / 20 / -30+75 /100R ✍ = User to specify

✍		✍		✍		✍		✍		✍		✍
X32	-	16.000	-	10	-	15	/	20	/	-30+75	/	100R
(1)		(2)		(3)		(4)		(5)		(6)		(7)

(1) Package code ; (2) Frequency in MHz ; (3) Load Capacitance in pF or "S" for series resonance ; (4) Frequency tolerance at 25°C ; (5) Frequency stability ;
 (6) Operating temperature range -30°C to +75°C in this example. Use " X " for -10°C ~ 60°C ; Use " Y " for -20°C ~ 70°C ; Use " I " for -40°C ~ 85°C ; (7) ESR max.

How To Specify A Crystal Oscillator

Output Wave Forms and Logics

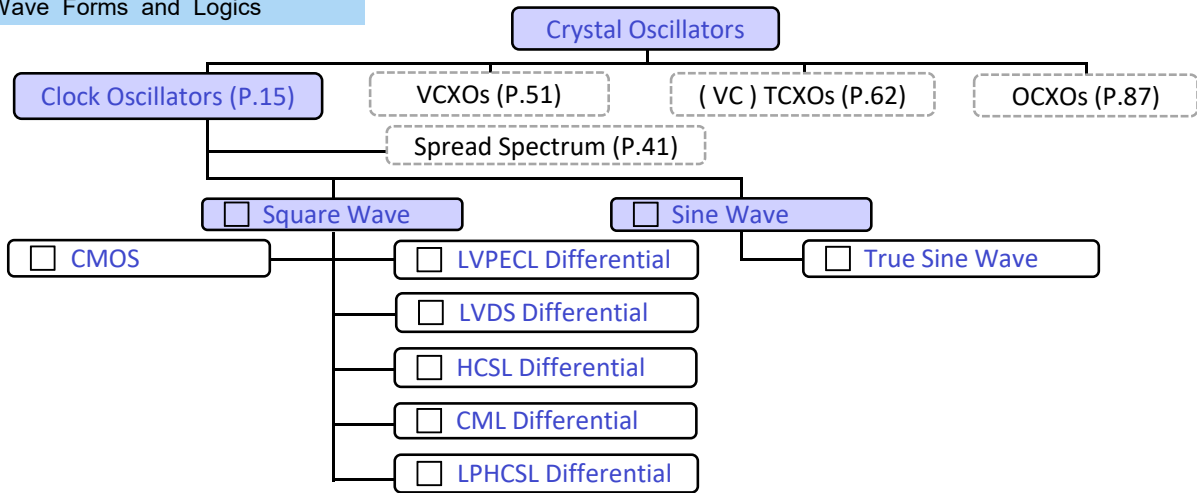

Part Number Format : " H " --- for Oscillators

" _ " --- represents PRODUCT SERIES selections in table 1 and 2 below .

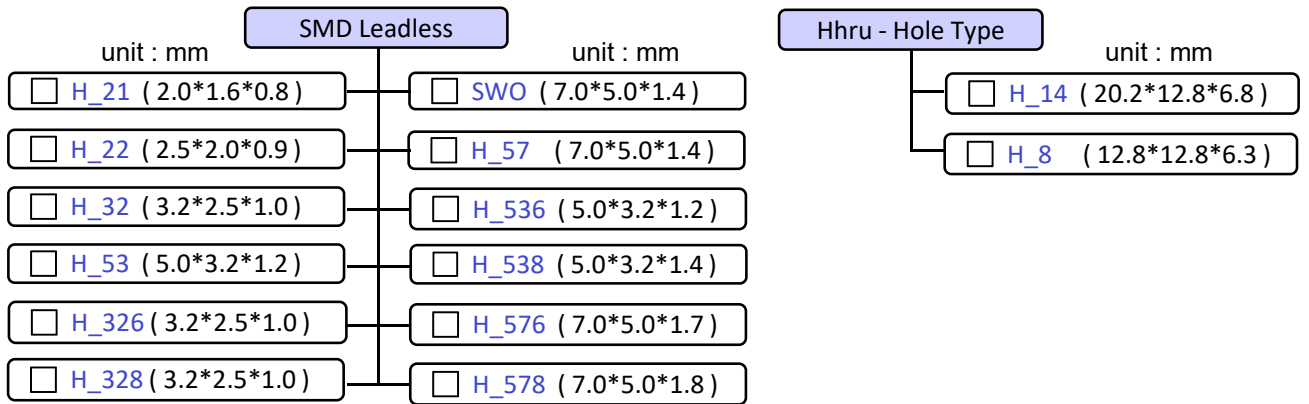

Basic Spec. must be specified

1 : Holder type with output wave : _____ Thru-Hole type SMD type

Output Wave	General Clock Oscillators	Switchable Output
<input type="checkbox"/> CMOS	H_ , SWO, HA, HM, HTF, HU, HW, HTJFN	HCTQF
<input type="checkbox"/> LVPECL	HPK, HPQN, HPQF, HPJK, HPEK, HPRK, HPJFN	HCPQF
<input type="checkbox"/> LVDS	HDK, HDQN, HDQF, HDJK, HDEK, HDRK, HDJFN	HCDQF
<input type="checkbox"/> HCSL	HCK, HCJK, HCEK, HCRK, HCJFN	
<input type="checkbox"/> CML	HQJF, HQJFN	
<input type="checkbox"/> LPHCSL	HCLK	

Output Wave	Product Series
<input type="checkbox"/> True Sine Wave	HS

2 : Frequency : _____ MHz or _____ KHz

3 : Input Voltage : +5.0V +3.3V +3.0V +2.5V +1.8V +1.2V +1.0V others : _____

4 : Frequency Stability :

Stability / Temp .	Commercial: -20°C ~ +70°C	Industrial: -40°C ~ +85°C	Extended Industrial: -40°C ~ +105°C
± 25ppm	<input type="checkbox"/> A	<input type="checkbox"/> D	<input type="checkbox"/> G
± 50ppm	<input type="checkbox"/> B	<input type="checkbox"/> E	<input type="checkbox"/> H
± 100ppm	<input type="checkbox"/> C	<input type="checkbox"/> F	<input type="checkbox"/> J
<input type="checkbox"/> Custom (± _____ ppm over _____ to _____ °C)			

5 : Output Logic " 1 " _____ V (min.) ; Output Logic " 0 " _____ V (max.)

6 : Rise time (Tr) and Fall time (Tf) : _____ nano seconds (max.)

7 : Start-up time : _____ mini seconds (max.)

8 : Current Consumption : _____ mA (max.) or _____ uA (max.)

9 : Symmetry (Duty Cycle) : Standard (50%±10%) Option (50%±5%) [Add " S " at the end of part number]

10 : Pin 1 options : No Connection Tri - state (Output Enable) Power-down (Note : Tri-state is standard for SWO , H53 and H32 series)

Part Number Format and Example

Example: 3H14 - DT - 33.000 - S						✍ = User to specify	★ = Option
✍	✍		✍	★		✍	★
3	H14	-	D	T	-	33.000	S
(1)	(2)		(3)	(4)		(5)	(6)
(1) Supply voltage code : " 3 " for "+3.3V" ; " 5 " for "+5.0V" ;							
(2) Package code ; (3) Frequency Stability ; (4) Tri-state option. Omit "T" if not required							
(5) Center Frequency in MHz ; (6) Add " S " for 50% ± 5% duty cycle . Omit " S " if not required .							

How To Specify A EMI Reduction Spread Spectrum Clock Oscillator

Holder Type

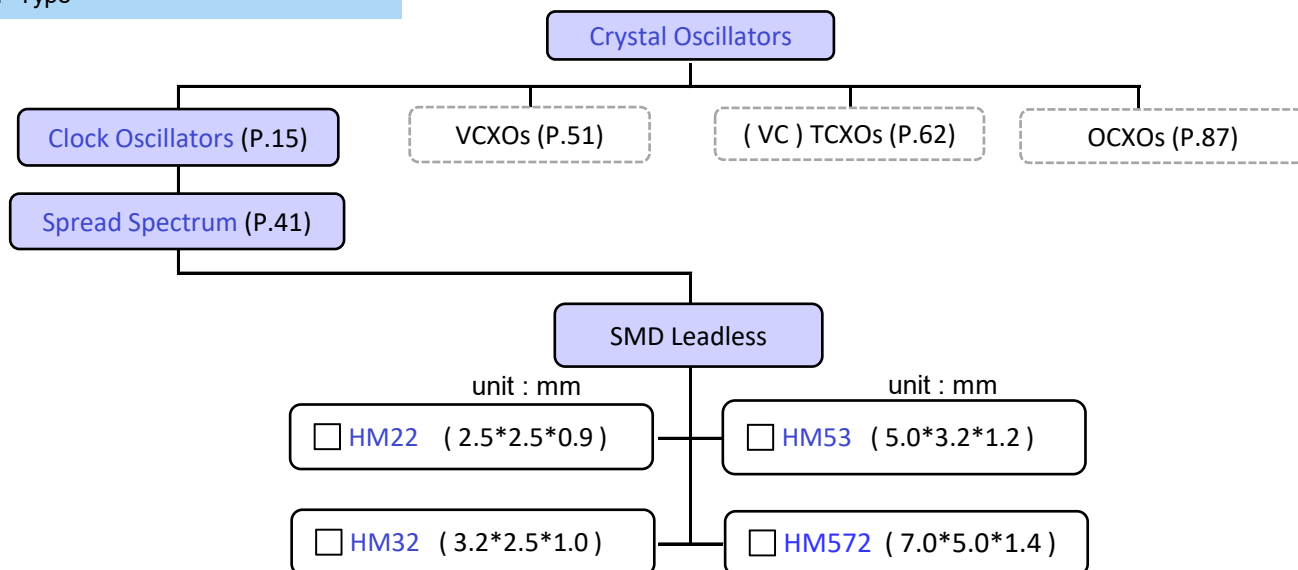

Basic Spec. must be specified

1 : Holder type: _____ Thru-Hole type SMD type

2 : Frequency : _____ MHz

3 : Input Voltage : +1.8V , +2.5V , +3.3V

4 : Output Wave : Square Wave (CMOS)

5 : Frequency Stability :

(Exclude frequency modulation)

Stability / Temp .	Commercial -20°C ~ +70 °C	Industrial -40°C ~ +85 °C
<input type="checkbox"/> ± 25ppm	<input type="checkbox"/> A	<input type="checkbox"/> D
<input type="checkbox"/> ± 50ppm	<input type="checkbox"/> B	<input type="checkbox"/> E
<input type="checkbox"/> ± 100ppm	<input type="checkbox"/> C	<input type="checkbox"/> F
<input type="checkbox"/> Custom (± _____ ppm over _____ to _____ °C)		

6 : Group & Spread type :

(1) Group B

- Center spread : ±0.125 % ±0.375 % ±0.625 % ±0.875 % ±1.125 % ±1.375 % ±1.625 %
 ±0.875 % ±1.125 % ±1.375 % ±1.625 % ±1.875 % ±2.0 %
 Down spread : -0.25 % -0.75 % -1.25 % -1.75 % -2.25 % -2.75 % -3.25 %
 -3.75 % -4.0 %

(2) Group C

- Center spread : C0.25 : ± 0.25 % C0.75 : ± 0.75 % C1.0 : ± 1.0 %
 Down spread : D0.5 : -0.5 % D1.5 : - 1.5 % D2.0 : -2.0 %

Part Number Format and Example

Examples of Low EMI Oscillator : 3HM572-DT-33.000B-C0.5

= User to specify ★ = Option

			★						
3	HM572	-	D	T	-	33.000	B	-	C0.5
(1)	(2)	(3)	(4)	(5)	(6)	(7)			

(1) Supply voltage code : " 3 " for +3.3V ; (2) Package code ; (3) Frequency stability ;
 (4) Tri-state ; (5) Frequency in MHz ; (6) Group ;
 (7) Spread type & percentage : " C " for center spread , " D " for down spread. C0.5 represents center spread ± 0.5% (total 1%).

How To Specify A VCXO

Holder Type

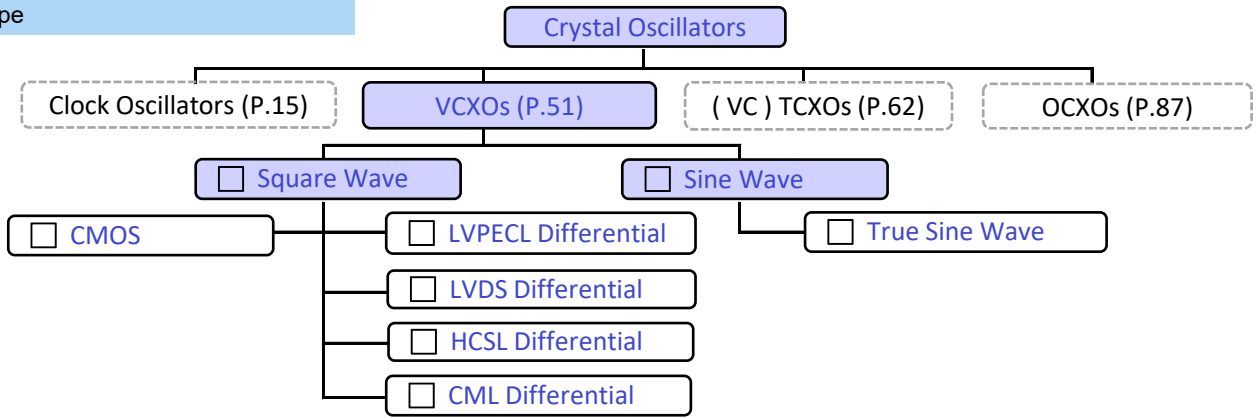

Part Number Format : " G " --- for VCXO

" _ " --- represents PRODUCT SERIES selections in table 1 and 2 below .

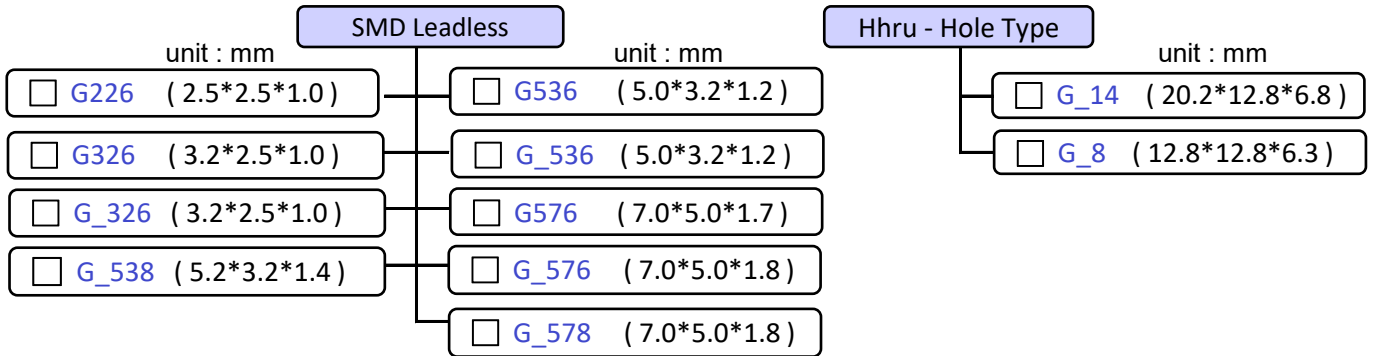

Basic Spec. must be specified

1 : Holder type : _____ Thru-Hole type Leadless SMD type

Output Wave	General VCXOs	Switchable Output
<input type="checkbox"/> CMOS	G_ , GTQN , GTQF , GTJFN	GCTQF
<input type="checkbox"/> LVPECL	GPQN , GPQF , GPJFN	GCPQF
<input type="checkbox"/> LVDS	GDQN , GDQF , GDJFN	GCDQF
<input type="checkbox"/> HCSL	GCJFN	GCPQF
<input type="checkbox"/> CML	GQJFN	GCDQF

Output Wave	Product Series
<input type="checkbox"/> True Sine Wave	GS

2 : Frequency : _____ MHz

3 : Input Voltage :

<input type="checkbox"/> +3.3V	<input type="checkbox"/> +1.8V
+1.65V ± 1.35V (0.3V ~ 3.0V)	+0.9V ± 0.9V (0V ~ 1.8V)

4 : Control Voltage center and range :

5 : Frequency Stability :

Stability / Temp .	Commercial: -20°C ~ +70°C	Industrial: -40°C ~ +85°C	Extended Industrial: -40°C ~ +105°C
± 25ppm	<input type="checkbox"/> A	<input type="checkbox"/> D	<input type="checkbox"/> G
± 50ppm	<input type="checkbox"/> B	<input type="checkbox"/> E	<input type="checkbox"/> H
± 100ppm	<input type="checkbox"/> C	<input type="checkbox"/> F	<input type="checkbox"/> J
<input type="checkbox"/> Custom (± _____ ppm over _____ to _____ °C)			

6 : Frequency deviation range : ± _____ ppm min. max. typical (± 20%) .

7 : Linearity : _____ % (max.)

8 : Input Impedance : _____ KΩ (min.)

9 : Modulation band width : ± _____ KHz (min.)

Part Number Format and Example

Examples of VCXO : 3G576 - D - 150M - 27.000							= User to specify
3	G576	-	D	-	150M	-	27.000
(1)	(2)		(3)		(4)		(5)
(1) Supply Voltage code : " 18 " for +1.8V , " 3 " for +3.3V ; (2) Package code ; (3) Frequency stability ;							
(4) Pulling range in ppm (" N " : minimum , " M " : maximum , " T " : typical) ; (5) Center Frequency in MHz							

How To Specify A (VC)TCXO

Holder Type

Crystal Oscillators

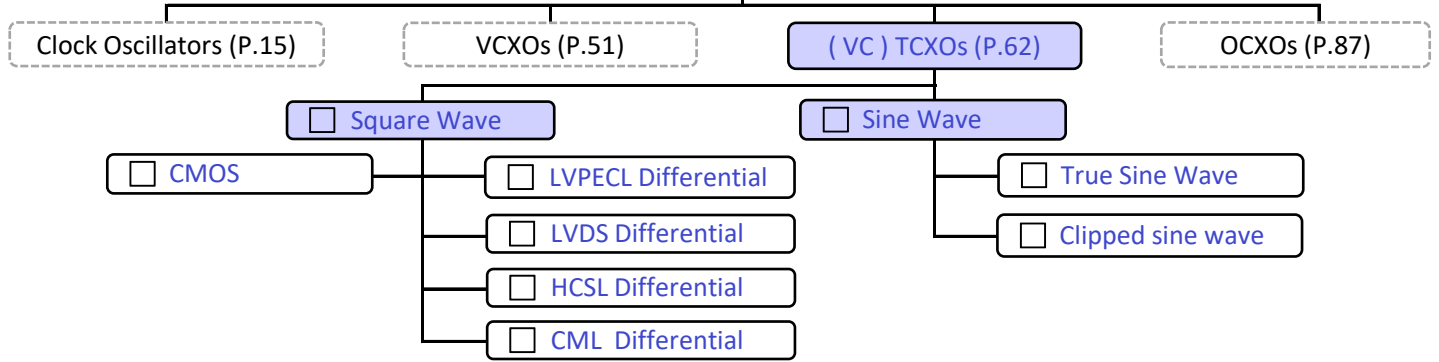

Part Number Format : " M " for TCXO ; " VM " for VCTCXO (TCXO with voltage control function)

" _ " --- represents PRODUCT SERIES selections in table 1 and 2 below .

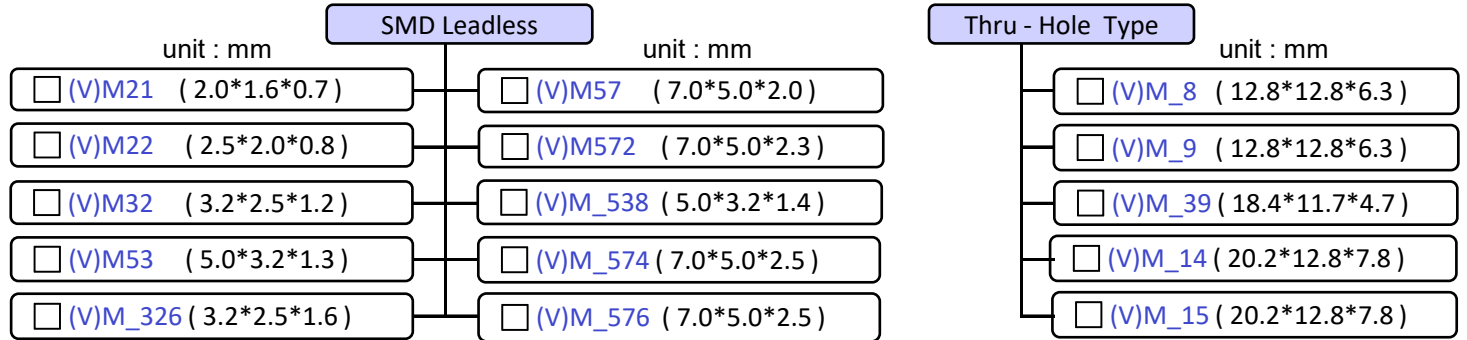

Basic Spec. must be specified

- 1: TCXO (code " M " series) VCTCXO (code " VM " series)
 2: Holder type: _____ Thru-Hole type SMD type
 Output Wave type :

Clipped Sine Wave	
TCXO	VCTCXO
M_ S	VM_ S

Output Wave	Square Wave	
	Product Series	
	TCXO --- " M "	VCTCXO --- " VM "
<input type="checkbox"/> CMOS	M_T , MTF_T , ME_T , MQN_T , MQF_T	VM_T , VMTF_T , VMQN_T , VMQF_T
<input type="checkbox"/> LVPECL	MQN_P , MQF_P , MJF_P	VMQN_P , VMQF_P , VMJF_P
<input type="checkbox"/> LVDS	MQN_D , MQF_D , MJF_D	VMQN_D , VMQF_D , VMJF_D
<input type="checkbox"/> HCSSL	MJF_C	VMJF_C
<input type="checkbox"/> CML	MJF_Q	VMJF_Q

- 3: Frequency : _____ MHz or _____ KHz
 4: Input Voltage : +3.3V +3.0V +2.5V +1.8V others : _____
 5: Frequency Stability : ± 1.0ppm ± 1.5ppm ± 2.0ppm
 ± 2.5ppm ± 3.0ppm ± 5.0ppm
 6: Operating Temp. : 0 °C ~ +60 °C 0 °C ~ +70 °C -10 °C ~ +60 °C -20 °C ~ +70 °C
 -30 °C ~ +60 °C -30 °C ~ +70 °C -40 °C ~ +85 °C
 7: ● [" T " series , Square Wave] : Output Voltage " 1 " : _____ V (min.) ; Output Voltage " 0 " : _____ V (max.)
 ● [" S " series , Clipped Sine Wave] : Output Voltage Level : _____ Vp-p (min.)
 8: Start-up time : _____ mini seconds (max.) .
 9: Current Consumption : _____ mA (max.)
 10: ● Mechanical frequency tuning (MFT) range : ± _____ ppm (min.) . For TCXOs and VCTCXOs.
 ● Electrical frequency tuning range (EFT) : ± _____ ppm (min.) . For VCTCXOs only.
 ● Control voltage center and range : **1.5V ± 1.0V** is standard for 3.3V, 1.5V supply voltages .

Part Number Format and Example

Examples of VCTCXO : VM32S33-12.800-2.5/-30+85 = User to specify

										customer to specify
V	M32	S	33	-	12.800	-	2.5	/	-30+85	
(1)	(2)	(3)	(4)		(5)		(6)		(7)	

(1) " V " for VCTCXO ; Omit " V " if TCXO ; (2) Package code
 (3) Wave form code " S " for clipped sine wave ; (4) Supply voltage code: " 25 " for +2.5V , " 3 " for +3.0V , " 33 " for +3.3V
 (5) Frequency in MHz ; (6) Frequency stability in ±ppm ; (7) Operating temperature range in °C. "-30+85" represents -30°C to +85°C operating temperature range.

How To Specify A OCXO

Holder Type

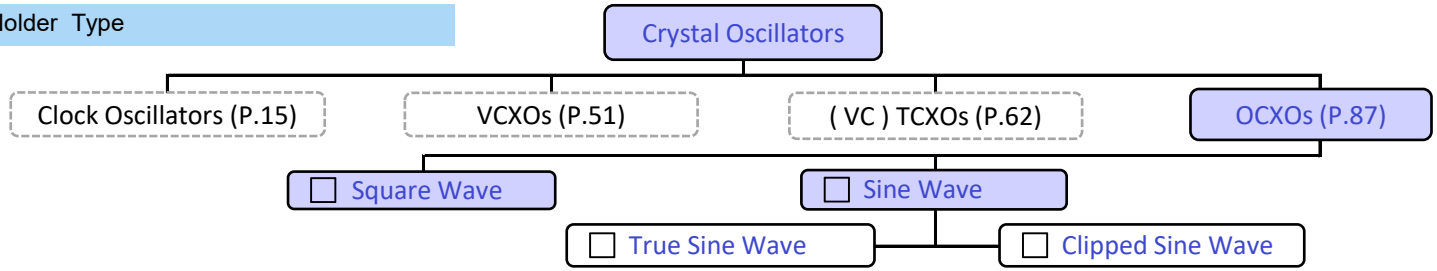

Part Number Format : " OC " for OCXO

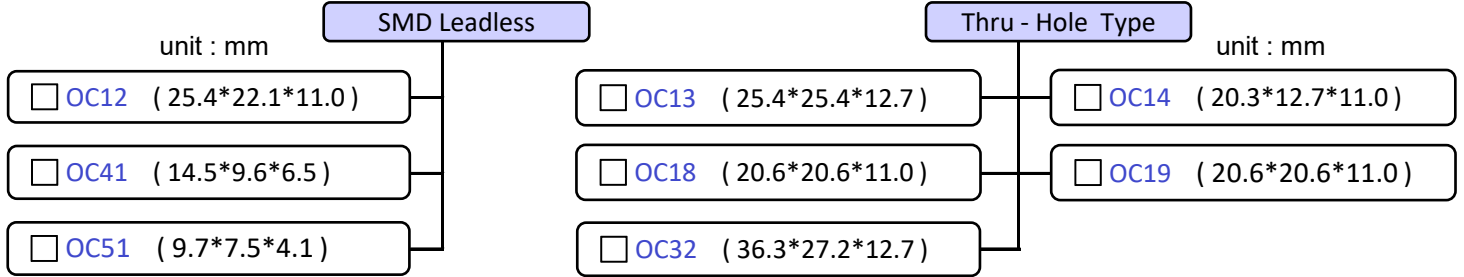

Basic Spec. must be specified

- 1: Holder type: _____ SMD type Thru-Hole type
- 2: Frequency : _____ MHz
- 3: Input Voltage : +3.3V +5.0V
- 4: Frequency Stability :

<input type="checkbox"/> ± 3.0ppm	<input type="checkbox"/> ± 5.0ppm	<input type="checkbox"/> ± 10.0ppm
<input type="checkbox"/> ± 20.0ppm	<input type="checkbox"/> ± 30.0ppm	<input type="checkbox"/> ± 50.0ppm
<input type="checkbox"/> ± 100.0ppm		
- 5: Operating Temp. :

<input type="checkbox"/> 0 °C ~ +70 °C	<input type="checkbox"/> -20 °C ~ +70 °C	<input type="checkbox"/> -30 °C ~ +70 °C	<input type="checkbox"/> -40 °C ~ +85 °C
--	--	--	--
- 6: ● [" T " series , Square Wave] : Output Voltage " 1 " : _____ V (min.) ; Output Voltage " 0 " : _____ V (max.)
- [" E " series , True Sine Wave] : Output Voltage Level : _____ dBm (typ.)
- [" S " series , Clipped Sine Wave] : Output Voltage Level : _____ Vp-p (min.)
- 8: Power Dissipation : _____ Watts (max.) at Steady-State ; _____ mA (max.) at Turn-On
- 9: Electrical frequency tuning range (EFT) : ± _____ ppm (min.).

Part Number Format and Example

Examples of OCXO : OC51T3-10.000-20/-40+85										= User to specify	
											customer to specify
OC	51	T	3	-	10.000	-	20	/	-40+85		
(1)	(2)	(3)	(4)		(5)		(6)		(7)		
(1) " OC " for OCXO ; (2) Package code ; (3) Wave form code " T " for square wave (4) Supply voltage code : " 3 " for +3.3V ; (5) Frequency in MHz (6) Frequency stability in ±ppb ; (7) Operating temperature range in °C. "-40+85" represents -40°C to +85°C operating temperature range.											

How To Specify A Monolithic Crystal Filter

Holder Type

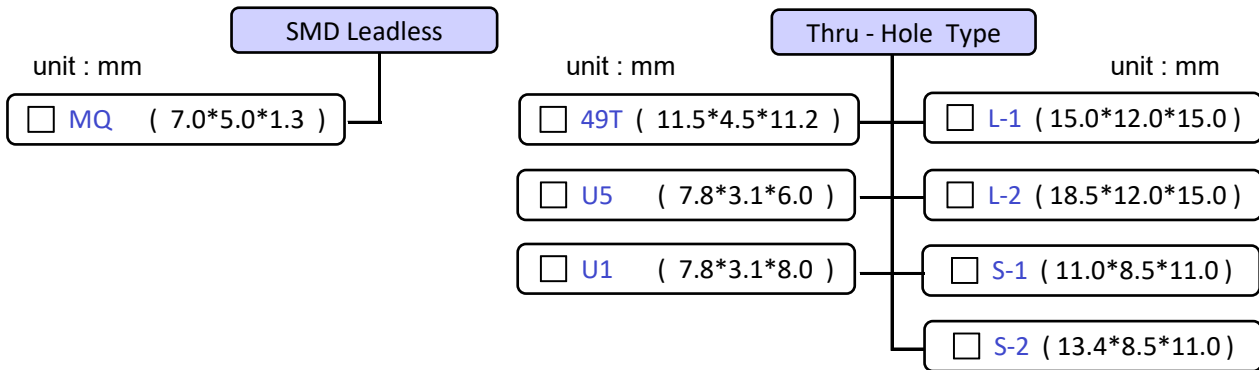

Basic Spec. must be specified

A-1 : Holder type: _____ SMD Leadless Thru-Hole type

A-2 : Frequency : _____ MHz 10.7 MHz (10.5 MHz ~ 11.000 MHz available only in 49T series)

21.400 MHz 21.700 MHz 45.000 MHz 50.850 MHz

A-3 : No. of poles : 2 poles 4 poles 6 poles 8 poles

A-4 : Pass Bandwidth : ±3.75 KHz ±6.0 KHz ±7.5 KHz ±15.0 KHz min at 3 dB

A-5 : Stop Bandwidth : ± _____ KHz max at _____ dB and ± _____ KHz max at _____ dB

A-6 : Ripple : _____ dB (max.)

A-7 : Insertion Loss : _____ dB (max.)

A-8 : Guaranteed Attenuation : fo + _____ KHz to fo - _____ KHz min. at _____ dB

A-9 : Terminating Impedance : _____ Ω // _____ pF

A-10 : Operating Temperature : _____ °C to _____ °C

Part Number Format and Example

Examples of quartz crystal : 21.7M15DU5				= User to specify	★ = Option
					User to specify
21.7 M	15	D	U5		
(1)	(2)	(3)	(4)		
(1) Frequency code ;					
(2) Pass Bandwidth code (" 7.5 " for ±3.75 KHz band width, " 15 " for ±7.5 KHz band width, " 30 " for ±15.0 KHz band width) ;					
(3) No. of poles (" A " for 2 poles , " B " for 4 poles , " C " for 6 poles , " D " for 8 poles) ;					
(4) Package code					

Quartz Crystals

X11	X21	X22	X32	Surface Mount	X11, X21, X22, X32 Fundamental	X22, X32 3rd Overtone
1.65 * 1.25 * 0.30	2.05 * 1.65 * 0.50	2.55 * 2.05 * 0.60	3.20 * 2.50 * 0.70			

Features

Specifications

- The entire package can be grounded via the top metal lid and the two bottom pads
- Small footprint. Ideal for space constrained applications
- Exhibits extremely low aging with a high shock & vibration resistance



General Specifications

Item / Type	X11	X21	X22	X32
Package Dimensions	(1.65 * 1.25 * 0.30 mm)	(2.05 * 1.65 * 0.50 mm)	(2.55 * 2.05 * 0.60 mm)	(3.20 * 2.50 * 0.70 mm)
Frequency Range	24.0 ~ 96.0 MHz (Fund.)	16.0 ~ 64.0 MHz (Fund.)	12.0 ~ 80.0 MHz (Fund.) 50 ~ 200 MHz (3rd Overtone)	8 ~ 96.0 MHz (Fund.) 50 ~ 200 MHz (3rd Overtone)
Crystal Cut // Load Capacitance	AT - Cut // Series or Parallel (8 to 32 pF) resonance			
Drive Level	10 μW (typ.) 100 μW (max.)			
Frequency Tolerance	± 10 ppm , ± 20 ppm or ± 30 ppm (max.) at 25°C			
Aging	ΔF / F : ± 3 ppm / year (max.)			
Storage Temperature Range	- 50°C to 125°C			

ESR (Equivalent Series Resistance)

X11		X21		X22			X32		
Frequency Range	E. S. R.	Frequency Range	E. S. R.	Frequency Range	E. S. R.	Oscillator Mode	Frequency Range	E. S. R.	Oscillator Mode
24.0 ~ 29.9 MHz	120 Ω max.	16.0 ~ 23.9 MHz	120 Ω max.	12.0 ~ 15.9 MHz	150 Ω max.	Fund. Mode	8.0 ~ 9.9 MHz	500 Ω max.	Fund. Mode
30.0 ~ 39.9 MHz	100 Ω max.	24.0 ~ 29.9 MHz	100 Ω max.	16.0 ~ 29.9 MHz	80 Ω max.		10.0 ~ 11.9 MHz	200 Ω max.	
40.0 ~ 96.0 MHz	80 Ω max.	30.0 ~ 37.9 MHz	80 Ω max.	30.0 ~ 80.0 MHz	60 Ω max.		12.0 ~ 29.9 MHz	80 Ω max.	
		38.0 ~ 64.0 MHz	60 Ω max.	50.0 ~ 200.0 MHz	80 Ω max.	3rd Overtone	30.0 ~ 96.0 MHz	40 Ω max.	
							50.0 ~ 200.0 MHz	60 Ω max.	3rd Overtone

Frequency stability Vs Operating temperature range

Frequency stability Vs Operating temperature range							
Stability code	Temp. (°C) \ ppm	± 5	± 10	± 15	± 20	± 25	± 30
X	-10 to 60°C	▲	○	○	○	○	○
Y	-20 to 70°C		○	○	○	○	○
I	-40 to 85°C			○	○	○	○

○ : available

▲ : contact Mercury

Outline Dimensions (Unit : mm)

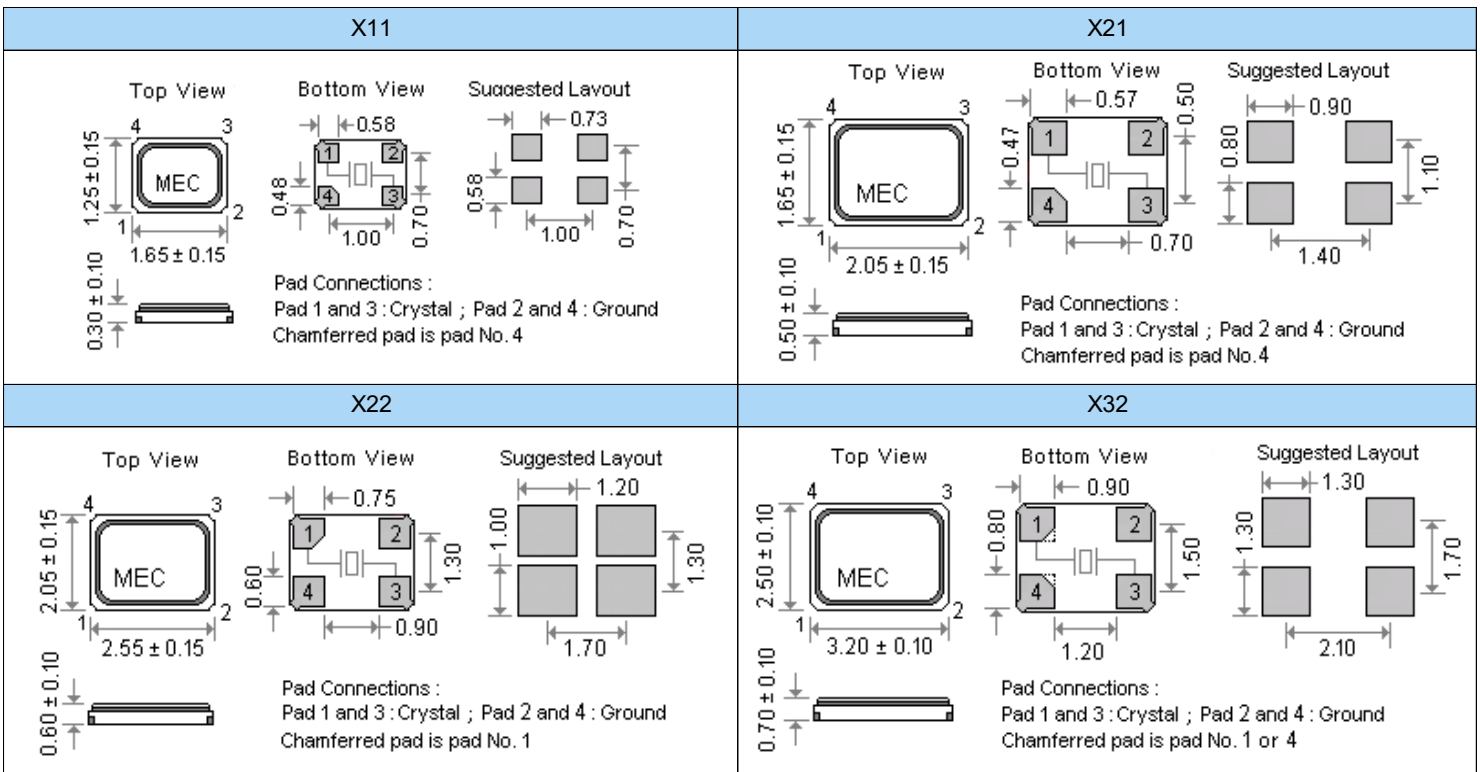

Quartz Crystals

MJ

5.0 * 3.2 * 0.9

MQ

7.0 * 5.0 * 1.0

Surface Mount

MJ , MQ

Fundamental

MJ , MQ

3rd Overtone

Features

Specifications

- Exhibits extremely low aging with a high shock and vibration resistance
- The entire package can be grounded via the top metal lid and the two bottom pads
- This low 0.7mm package height is ideal for height constrained applications

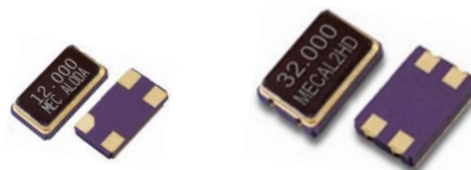

General Specifications

Item / Type	MJ series	MQ series
Package Dimensions	(5.0 * 3.2 * 0.9 mm)	(7.0 * 5.0 * 1.0 mm)
Frequency Range	8.0 ~ 52.0 MHz (Fund.)	6.0 ~ 50.0 MHz (Fund.)
	50.0 ~ 200.0 MHz (3rd)	45.0 ~ 200.0 MHz (3rd)
Crystal Cut	AT - Cut ; 3rd overtone	
Load Capacitance	Series or Parallel (8 to 32 pF) resonance	
Drive Level	10 μW (typ.) 100 μW (max.)	
Frequency Tolerance	± 10 ppm , ± 20 ppm or ± 30 ppm (max.) at 25°C	
Aging	ΔF / F : ± 3 ppm / year (max.)	
Storage Temp. Range	- 50°C to 125°C	

ESR (Equivalent Series Resistance)

MJ			MQ		
Freq. (MHz)	E.S.R.	Mode	Freq. (MHz)	E.S.R.	Mode
8.0 ~ 9.9	100 Ω	Fund.	6.0 ~ 8.0	80 Ω	Fund.
10.0 ~ 14.9	60 Ω		8.1 ~ 11.0	60 Ω	
15.0 ~ 19.9	50 Ω		11.1 ~ 14.0	50 Ω	
20.0 ~ 52.0	40 Ω		14.1 ~ 50.0	40 Ω	
50.0 ~ 200.0	80 Ω	3rd	40.1 ~ 45.0	60 Ω	3rd
			45.1 ~ 200.0	80 Ω	

Frequency stability Vs Operating temperature range

Frequency stability vs Operating temperature range							
Stability code	Temp. (°C) \ ppm	± 5	± 10	± 15	± 20	± 25	± 30
X	-10 to 60°C	○	○	○	○	○	○
Y	-20 to 70°C	▲	○	○	○	○	○
I	-40 to 85°C			○	○	○	○

○ : available

▲ : contact Mercury

Outline Dimensions (Unit : mm)

MJ			MQ		
<p>Top View</p>	<p>Bottom View</p>	<p>Suggested Layout</p>	<p>Top View</p>	<p>Bottom View</p>	<p>Suggested Layout</p>
<p>Pad connections : Pad 1 , 3 : Crystal ; Pad 2 , 4 : Ground Chamfered pad is pad No. 1 or 3</p>			<p>Pad connections : Pad 1 , 3 : Crystal ; Pad 2 , 4 : Ground Chamfered pad is pad No. 1 or 4</p>		

Quartz Crystals

M49 , ML49

12.4 * 4.5 * 4.0 (3.0) mm

MP4 , MP5

12.9 * 4.5 * 5.0 (4.0) mm

MP24 , MP25

11.4 * 5.0 * 5.0 (4.0) mm

SMD

Fundamental

3rd Overtone

Min.
3.2 MHz

Max.
100 MHz

Features

Specifications

- Withstands solder reflow and available in EIA-481A tape and reel
- AT-strip crystal inside. Optimized for low spurious.
- Lowest cost among all Mercury SMD crystals
- Designed for top board assembly and an one time solder reflow only
- Do not mount with the metal housing downward



General Specifications

Item / Type	M49 (12.4 * 4.5 * 4.0 mm) series	MP4 (12.9 * 4.5 * 4.0 mm) series	MP5 (12.9 * 4.5 * 5.0 mm) series
	ML49 (12.4 * 4.5 * 3.0 mm) series	MP24 (11.4 * 5.0 * 4.0 mm) series	MP25 (11.4 * 5.0 * 5.0 mm) series
Frequency Range & Crystal Cut	3.200 ~ 48.000 MHz , AT-cut , Fundamental Mode (see Table 1) 30.000 ~ 100.000 MHz , AT-cut , 3rd overtone (see Table 1)		
Load Capacitance	Series or Parallel (8 to 32 pF) resonance		
Drive Level	100 μ W (typ.) 500 μ W (max.)		
Frequency Tolerance	\pm 10 ppm , \pm 20 ppm or \pm 30 ppm (max.) at 25°C		
Frequency Stability	See Table 2		
Aging	Δ F / F : \pm 3 ppm / year (max.)		
Storage Temperature Range	- 50°C to 105°C		

Table 1

ESR (Equivalent Series Resistance)					
Freq.(MHz)	E.S.R.	Osc. Mode	Freq.(MHz)	E.S.R.	Osc. Mode
3.2 ~ 3.4	300 Ω	AT , Fund.	30.1 ~ 50.0	100 Ω	AT , 3rd
3.5 ~ 6.0	120 Ω		50.1 ~ 100.0	80 Ω	
6.1 ~ 10.0	60 Ω				
10.1 ~ 48.0	40 Ω				

Table 2

Frequency stability Vs Operating temperature range						
Stability code	Temp. (°C) \ ppm	\pm 10	\pm 15	\pm 20	\pm 25	\pm 30
X	-10 to 60°C	○	○	○	○	○
Y	-20 to 70°C	▲	○	○	○	○
I	-40 to 85°C		○	○	○	○

○ : available ; ▲ : contact Mercury

Outline Dimensions (Unit : mm)

[M49] ; [ML49]	[MP4] ; [MP5]	[MP24] ; [MP25]																		
<p>Side View 9.9 ± 0.2 1.0 max.</p> <p>Top View 12.4 ± 0.2 MEC</p> <p>Bottom View 11.2 ± 0.2 4.5 ± 0.2 4.3 ± 0.2 0.75 max.</p> <p>Suggested Layout 5.5 3.0 1.5</p> <p>Poly Phenylene Sulfide Insulator</p>	<p>Side View 10.2 1.8</p> <p>Top View 12.9 ± 0.2 4.5 ± 0.2 MEC</p> <p>Bottom View 1.3 2.1 9.0</p> <p>Suggested Layout 2.2 2.3 3.6 9.0</p> <p>Plastic molded base Lead frame contacts</p>	<p>Side View 10.2 1.8</p> <p>Top View 11.4 ± 0.2 5.0 ± 0.2 MEC</p> <p>Bottom View 1.6 3.0 4.88</p> <p>Suggested Layout 2.2 2.4 3.6 4.0 4.88</p> <p>Plastic molded base Lead frame contacts</p>																		
<table border="1"> <thead> <tr> <th>MEC P/N</th> <th>H (height)</th> </tr> </thead> <tbody> <tr> <td>M 49</td> <td>4.0 mm (max.)</td> </tr> <tr> <td>ML 49</td> <td>3.0 mm (max.)</td> </tr> </tbody> </table>	MEC P/N	H (height)	M 49	4.0 mm (max.)	ML 49	3.0 mm (max.)	<table border="1"> <thead> <tr> <th>MEC P/N</th> <th>H (height)</th> </tr> </thead> <tbody> <tr> <td>MP 5</td> <td>5.0 mm (max.)</td> </tr> <tr> <td>MP 4</td> <td>4.0 mm (max.)</td> </tr> </tbody> </table>	MEC P/N	H (height)	MP 5	5.0 mm (max.)	MP 4	4.0 mm (max.)	<table border="1"> <thead> <tr> <th>MEC P/N</th> <th>H (height)</th> </tr> </thead> <tbody> <tr> <td>MP 25</td> <td>5.0 mm (max.)</td> </tr> <tr> <td>MP 24</td> <td>4.0 mm (max.)</td> </tr> </tbody> </table>	MEC P/N	H (height)	MP 25	5.0 mm (max.)	MP 24	4.0 mm (max.)
MEC P/N	H (height)																			
M 49	4.0 mm (max.)																			
ML 49	3.0 mm (max.)																			
MEC P/N	H (height)																			
MP 5	5.0 mm (max.)																			
MP 4	4.0 mm (max.)																			
MEC P/N	H (height)																			
MP 25	5.0 mm (max.)																			
MP 24	4.0 mm (max.)																			

Quartz Crystals

H49
10.7 * 4.5 * 13.2 mm

HUS
10.7 * 4.3 * 3.5 mm

HUSL
10.7 * 4.3 * 2.5 mm

Thru - Hole

Fund.

3rd O.T.

Min.
1.8 MHz

Max.
100 MHz

Features

Specifications

- Tight tolerance and stability. Ideal for communication equipment
- RoHS complian
- H49 (13.2mm height) & HUS (3.5mm height) & HUSL (2.5mm height)
- Low cost and light weight

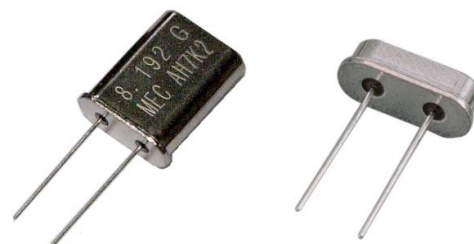

General Specifications

Item / Type	H49 (10.7 * 4.5 * 13.2 mm) series	HUS (10.7 * 4.3 * 3.5 mm) series	HUSL (10.7 * 4.3 * 2.5 mm) series
Frequency Range & Crystal Cut	1.8432 ~ 100.000 MHz (see Table 1)	3.200 ~ 48.000 MHz , AT-cut , Fundamental Mode (see Table 2) 30.000 ~ 100.000 MHz , AT-cut , 3rd overtone (see Table 2)	
	For specific details , please feel free to contact us.		
Load Capacitance	Series or Parallel (8 to 32 pF) resonance		
Drive Level	100 μW (typ.) 500 μW (max.)		
Frequency Tolerance	± 10 ppm , ± 20 ppm or ± 30 ppm (max.) at 25°C		
Frequency Stability	See Table 3		
Aging	ΔF / F : ± 5 ppm & ± 3 ppm year (max.)		
Storage Temperature Range	- 55°C to 125°C		

Table 1

H49 ESR (Equivalent Series Resistance)					
Freq.(MHz)	E.S.R.	Osc. Mode	Freq.(MHz)	E.S.R.	Osc. Mode
1.8 ~ 1.9	650 Ω	AT , Fund.	4.0 ~ 4.9	70 Ω	AT , Fund.
2.0 ~ 2.4	450 Ω		5.0 ~ 7.9	60 Ω	
2.5 ~ 2.9	350 Ω		8.0 ~ 9.9	30 Ω	
3.0 ~ 3.9	90 Ω		10.0 ~ 50.0	30 Ω	
			30.0 ~ 100.0	60 Ω	AT , 3rd

Table 2

HUS & HUSL ESR (Equivalent Series Resistance)					
Freq.(MHz)	E.S.R.	Osc. Mode	Freq.(MHz)	E.S.R.	Osc. Mode
3.2 ~ 3.4	300 Ω	AT , Fund.	30.0 ~ 50.0	100 Ω	AT , 3rd
3.5 ~ 6.0	120 Ω		50.1 ~ 100.0	80 Ω	
6.1 ~ 10.0	60 Ω				
10.1 ~ 48.0	40 Ω				

Table 3

Frequency stability vs Operating temperature range								
Stability code	Temp. (°C) \ ppm	± 5	± 10	± 15	± 20	± 25	± 30	± 50
X	-10 to 60°C	○	○	○	○	○	○	○
Y	-20 to 70°C	▲	○	○	○	○	○	○
I	-40 to 85°C		▲	○	○	○	○	○

○ : available ; ▲ : contact Mercury

Outline Dimensions (Unit : mm)

H49	HUS / HUSL						
<p>glass insulator</p>	<p>glass insulator</p> <table border="1" style="margin-left: auto; margin-right: auto;"> <thead> <tr> <th>MEC P/N</th> <th>H (height)</th> </tr> </thead> <tbody> <tr> <td>HUSL</td> <td>2.5 ± 0.2 mm</td> </tr> <tr> <td>HUS</td> <td>3.5 ± 0.2 mm</td> </tr> </tbody> </table>	MEC P/N	H (height)	HUSL	2.5 ± 0.2 mm	HUS	3.5 ± 0.2 mm
MEC P/N	H (height)						
HUSL	2.5 ± 0.2 mm						
HUS	3.5 ± 0.2 mm						

Quartz Crystals

U1	U5
7.8 * 3.2 * 8.0 mm	7.8 * 3.2 * 6.0 mm

Thru - Hole

Fund.

3rd O.T.

Min.
3.2 MHz

Max.
100 MHz

Features

Specifications

- Round shaped AT-Cut crystal plate inside
- Annealed and pre-aged for low frequency drift over long-term operation



General Specifications

Item / Type	U1	U5
Frequency Range	3.2 ~ 100 MHz	8.0 ~ 100 MHz
Load Capacitance	Series or Parallel (8 to 32 pF) resonance	
Drive Level	100 μW (typ.) 500 μW (max.)	
Frequency Tolerance	AT-cut : ± 10 ppm , ± 20 ppm or ± 30 ppm (max.) at 25°C	
Frequency Stability	See Table 2	
Aging	ΔF / F : ±3 ppm / year (max.)	
Storage Temperature Range	- 55°C to 125°C	

Table 1

U1 ESR (Equivalent Series Resistance)		
Freq.(MHz)	E.S.R.	Osc. Mode
3.2 ~ 10.0	50 Ω	AT , Fund.
10.1 ~ 50.0	30 Ω	
30.0 ~ 100.0	40 Ω	AT , 3rd

U5 ESR (Equivalent Series Resistance)		
Freq.(MHz)	E.S.R.	Osc. Mode
8.0 ~ 45.0	30 Ω	AT , Fund.
45.1 ~ 74.125	60 Ω	
30.0 ~ 100.0	40 Ω	AT , 3rd

Table 2

Frequency stability vs Operating temperature range								
Stability code	Temp. (°C) \ ppm	± 5	± 10	± 15	± 20	± 25	± 30	± 50
X	-10 to 60°C	○	○	○	○	○	○	○
Y	-20 to 70°C	▲	○	○	○	○	○	○
I	-40 to 85°C		▲	○	○	○	○	○

○ : available

▲ : contact Mercury

Outline Dimensions (Unit : mm)

Thru - Hole type (U1 , U5)

	H	T1	T2
U1	8.0 ± 0.2	2.2 ± 0.2	3.2 ± 0.2
U5	6.0 ± 0.2	2.2 ± 0.2	3.2 ± 0.2

Quartz Crystals

Surface Mount

X2012

[2.05 * 1.2 * 0.55 mm]

X3215

[3.2 * 1.5 * 0.8 mm]

Thru - Hole type

T26

[2.0 ϕ * 6.0 mm]

T38

[3.0 ϕ * 8.0 mm]

32.768 KHz

Frequency Tolerance options

± 5 ppm

± 10 ppm

± 20 ppm

Features

Specifications

Ultra compact, thin, and light weight tuning fork crystal unit

- Excellent heat resistance and environmental characteristics
- Excellent electrical performance optimum for mobile communications, OA (office automation) and AV (audiovisual) applications
- RoHS Compliant. Meets the re-flow profiling requirements using lead-free solder



General Specifications

Frequency Range	32.768 KHz			
Hold type	Surface Mount Type		Thru - Hole Type	
Item / Type	X2012	X3215	T26	T38
Package sizes	[2.05 * 1.2 * 0.55 mm]	[3.2 * 1.5 * 0.8 mm]	[2.0 ϕ * 6.0 mm]	[3.0 ϕ * 8.0 mm]
Shunt Capacitance	1.3 pF (typ.) / 1.5 pF (max.)	1.0 pF (typ.) / 1.6 pF (max.)	1.5 pF (max.)	0.9 pF (max.)
Equivalent series resistance	80 K Ω (max.)		40 K Ω (max.)	35 K Ω (max.)
Temperature coefficient	$-0.04 \times 10^{-6} / ^\circ\text{C}^2$ (max.)		$-0.035 \times 10^{-6} / ^\circ\text{C}^2$ (max.)	
Drive Level	0.1 μW (typ.) 0.5 μW (max.)		1.0 μW (typ.)	
Operating Temperature Range	- 40 $^\circ\text{C}$ to 85 $^\circ\text{C}$		- 10 $^\circ\text{C}$ to 60 $^\circ\text{C}$	
Storage Temperature Range	- 40 $^\circ\text{C}$ to 125 $^\circ\text{C}$		- 40 $^\circ\text{C}$ to 85 $^\circ\text{C}$	
Crystal Cut	XT - Cut			
Load Capacitance	7 pF , 9 pF or 12.5 pF			
Frequency Tolerance	± 5 ppm , ± 10 ppm , ± 20 ppm (max.) at 25 $^\circ\text{C}$			
Turning POINT	+ 25 $^\circ\text{C}$ \pm 5 $^\circ\text{C}$			
Insulation resistance	500 M Ω min.			

Outline Dimensions (Unit : mm)

X2012		X3215	
T26		T38	
Frequency (Hz)		Frequency (Hz)	

Mercury Crystal Oscillators (XOs) Products Lineup

General Clock Oscillators Selection Guide

Output Wave Output Logic	Product Series	Supply Voltage	Frequency Range	Product Description / Features	
Square Wave CMOS	H (SMD)	1.8 V / 2.5 V / 3.3 V / 5.0 V	0.05 ~ 160 MHz	General Purpose Clock Oscillators.	
	H (Dip)				
	HA	1.8 V / 2.5 V / 3.3 V / 5.0 V	27.3 ~ 100.0 KHz	Standard Frequency 32.768 KHz , uA Current Consumption	
	HEA	1.8 V / 2.5 V / 3.3 V	32.768 KHz	Ultra Low Current Consumption	
	HU	1.0 V / 1.2 V	0.625 ~ 50 MHz	Low Supply Voltage	
	HY	1.8 V / 2.5 V / 3.3 V	1.25 ~ 50 MHz	Wide Operating Temperature Over : -40 °C to +125 °C	
	HJN	1.8 V / 2.5 V / 3.3 V	0.625 ~ 60 MHz	Ultra Low Jitter	
	HTF	1.8 V / 2.5 V / 3.3 V	1.0 ~ 200 MHz	Programmable Quick Turn XO	
	HTQN	2.5 V / 3.3 V	50 ~ 250 MHz	Low Jitter Oscillators , RMS Jitter : 0.6 psec (typ.)	
	HTQF	2.5 V / 3.3 V	10 ~ 250 MHz	Quick - Turn Clock Oscillators , RMS Jitter : 0.8 psec (typ.)	
	HTJFN	1.8 V / 2.5 V / 3.3 V	50 ~ 250 MHz	Quick - Turn Oscillators , Ultra Low Jitter : 150 fsec (typ.)	
	HM	B	2.5 V / 3.3 V	3.0 ~ 200 MHz	Spread Spectrum Oscillators , Programmable Quick Turn XO
		C	1.8 V / 2.5 V / 3.3 V	16 ~ 40 MHz	Spread Spectrum Oscillators , Reduce EMI More Than 3 dB
		HCTQF	2.5 V / 3.3 V	10 ~ 250 MHz	2 Frequency Switchable Oscillators
	HCTJFN	1.8 V / 2.5 V / 3.3 V	15 ~ 250 MHz	4 Frequencies Switchable Oscillators	
Square Wave LVPECL	HPK	2.5 V / 3.3 V	13.5 ~ 220 MHz	Differential XO with NO PLL , RMS Jitter : 0.2 psec (typ.)	
	HPRK	2.5 V / 3.3 V	100 ~ 250 MHz	Differential XO with NO PLL , RMS Jitter : 0.1 psec (typ.)	
	HPEK	3.3 V	13.5 ~ 220 MHz	Superb phase noise Differential XO , RMS Jitter : 98 fsec (typ.)	
	HPJK	2.5 V / 3.3 V	100 ~ 250 MHz	Ultra Low Jitter Differential XO , RMS Jitter : 50 fsec (typ.)	
	HPQN	2.5 V / 3.3 V	50 ~ 1,500 MHz	Low Jitter Oscillators , RMS Jitter : 0.6 psec (typ.)	
	HPQF	2.5 V / 3.3 V	10 ~ 1,500 MHz	Quick - Turn Clock Oscillators , RMS Jitter : 0.8 psec (typ.)	
	HPJFN	2.5 V / 3.3 V	50 ~ 2,100 MHz	Quick - Turn Oscillators , Ultra Low Jitter : 150 fsec (typ.)	
	HCPQF	2.5 V / 3.3 V	10 ~ 1,500 MHz	2 Frequencies Switchable XO	
	HCPJFN	2.5 V / 3.3 V	15 ~ 2,100 MHz	4 Frequencies Switchable XO	
Square Wave LVDS	HDK	1.8 V / 2.5 V / 3.3 V	13.5 ~ 220 MHz	Differential XO with NO PLL , RMS Jitter : 0.2 psec (typ.)	
	HDRK	1.8 V / 2.5 V / 3.3 V	10 ~ 250 MHz	Differential XO with NO PLL , RMS Jitter : 0.1 psec (typ.)	
	HDEK	2.5 V / 3.3 V	13.5 ~ 220 MHz	Superb phase noise Differential XO , RMS Jitter : 98 fsec (typ.)	
	HDJK	1.8 V / 2.5 V / 3.3 V	100 ~ 250 MHz	Ultra Low Jitter Differential XO , RMS Jitter : 50 fsec (typ.)	
	HDQN	2.5 V / 3.3 V	50 ~ 1,500 MHz	High Frequency Oscillators , RMS Jitter : 0.6 psec (typ.)	
	HDQF	2.5 V / 3.3 V	10 ~ 1,500 MHz	Quick - Turn Clock Oscillators , RMS Jitter : 0.8 psec (typ.)	
	HDJFN	1.8 V / 2.5 V / 3.3 V	50 ~ 2,100 MHz	Quick - Turn Oscillators , Ultra Low Jitter : 150 fsec (typ.)	
	HCDQF	2.5 V / 3.3 V	10 ~ 1,500 MHz	2 Frequencies Switchable XO	
		HCDJFN	1.8 V / 2.5 V / 3.3 V	15 ~ 2,100 MHz	4 Frequencies Switchable XO
Square Wave HCSL	HCK	1.8 V / 2.5 V / 3.3 V	13.5 ~ 220 MHz	Differential XO with NO PLL , RMS Jitter : 0.2 psec (typ.)	
	HCRK	1.8 V / 2.5 V / 3.3 V	20 ~ 220 MHz	Differential XO with NO PLL , RMS Jitter : 0.1 psec (typ.)	
	HCEK	2.5 V / 3.3 V	13.5 ~ 220 MHz	Superb phase noise Differential XO , RMS Jitter : 98 fsec (typ.)	
	HCJK	1.8 V / 2.5 V / 3.3 V	100 ~ 175 MHz	Ultra Low Jitter Differential XO , RMS Jitter : 50 fsec (typ.)	
	HCJFN	1.8 V / 2.5 V / 3.3 V	50 ~ 700 MHz	Quick - Turn Oscillators , Ultra Low Jitter : 150 fsec (typ.)	
		HCCJFN	1.8 V / 2.5 V / 3.3 V	15 ~ 700 MHz	4 Frequencies Switchable XO
Low Power HCSL	HCLK	1.8 V / 2.5 V / 3.3 V	95 ~ 180 MHz	Differential XO with NO PLL , RMS Jitter : 0.2 psec (typ.)	
Square Wave CML	HQJFN	1.8 V / 2.5 V / 3.3 V	50 ~ 2,100 MHz	Quick - Turn Oscillators , Ultra Low Jitter : 150 fsec (typ.)	
	HCQJFN	1.8 V / 2.5 V / 3.3 V	15 ~ 2,100 MHz	4 Frequencies Switchable XO	
Sine Wave	HS	3.3 V	10 ~ 200 MHz	Output level is greater than 0 dBm into 50 Ω load .	
		5.0 V	10 ~ 156 MHz	Output level is greater than 0 dBm into 50 Ω load .	

Surface Mount type

H21	H22	H32	H53	SWO	CMOS	1.8 V	3.3 V	Min.	Max.
2.0 * 1.6 * 0.8	2.5 * 2.0 * 0.9	3.2 * 2.5 * 1.0	5.0 * 3.2 * 1.2	7.0 * 5.0 * 1.4		2.5 V	5.0 V	50 KHz	160 MHz

Applications

- CPU , Graphics , Multimedia A / V clocks
- MPEG / DVD / HDTV clocks
- Laser engine pixel / set - top clocks
- SONET / SDH / ATM clocks
- Fast Ethernet and Gigabit Ethernet clocks
- NTSC / PAL encoder / decoder clocks
- PLL / synthesizer clocks
- Fibre channel and ADSL clocks

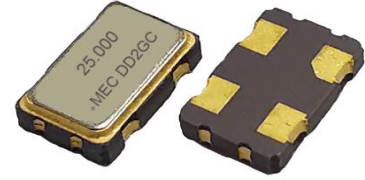

General Specifications [Ta = +25°C , V_{DD}= at specified voltage , Load : 15 pF]

Model	" H21 " ; " H22 " ; " H32 " ; " H53 " and " SWO " series				
Type	" H21 " series	" H22 " series	" H32 " series	" H53 " series	" SWO " series
Dimensions	2.0 x 1.6 x 0.8 mm	2.5 x 2.0 x 0.9 mm	3.2 x 2.5 x 1.0 mm	5.0 x 3.2 x 1.2 mm	7.0 x 5.0 x 1.4 mm
Available Frequency Range by Voltage	1.8 V	1 MHz ~ 60 MHz	0.0625 MHz ~ 160 MHz	0.0625 MHz ~ 160 MHz	0.05 MHz ~ 160 MHz
	2.5 V				
	3.3 V				
	5.0 V	----	1 MHz ~ 50 MHz	1 MHz ~ 50 MHz	0.05 MHz ~ 135 MHz

Supply Voltage (V _{DD})	+1.8 V ± 10%	+2.5 V ± 10%	+3.3 V ± 10%	+5.0 V ± 10%
	code is " 18 "	code is " 25 "	code is " 3 "	code is " 5 "
Output Logic " High " , " 1 "	1.62 V (min.)	2.25 V (min.)	2.97 V (min.)	4.5 V (min.)
Output Logic " Low " , " 0 "	0.18 V (max.)	0.25 V (max.)	0.33 V (max.)	0.5 V (max.)
Current Consumption	< 25 MHz	5 mA (max.)	5 mA (max.)	5 mA (max.)
	25 ~ 50 MHz	8 mA (max.)	10 mA (max.)	12 mA (max.)
	51 ~ 100 MHz	10 mA (max.)	15 mA (max.)	30 mA (max.)
	101 ~ 160 MHz	15 mA (max.)	20 mA (max.)	40 mA (max.)
Rise Time (Tr) / Fall Time (Tf)	6 nsec. (max.)			
	Measured between 10% ↔ 90% of wave form (CL = 15pF)			

Frequency Stability Codes	Frequency Stability over Operating Temperature Range	± 25 ppm	± 50 ppm	± 100 ppm	If non-standard , please enter the desired stability after the " C " or " F " For example : " C20 " ± 20 ppm over -20°C to +70°C ; " F30 " ± 30 ppm over -40°C to +85°C
	Commercial (-20°C to +70°C)	A	B	C	
	Industrial (-40°C to +85°C)	D	E	F	

Output Load	15 pF ; (30 pF and 50 pF load are also available for +3.3V and +5.0V V _{DD})
Duty Cycle	Standard: 50% ± 10% ; Option: 50% ± 5%. Please add "-S" at the end of the part number for ± 5% .
Start-up Time	1.0 ~ 32.0 MHz : 5 msec. (max.) ; 32.1 ~ 160.0 MHz : 10 msec. (max.)
Storage Temperature	-55°C to +125°C
Aging at Ta=+25°C	± 3 ppm per year (max.)
Output Enable / Disable Function	70% of V _{DD} (min.) to enable output.
	30% of V _{DD} (max.) to disable output.
	Disable current : 10 uA max. for OE ≤ 0.3V

Thru - Hole

H8

H14

CMOS

1.8 V

2.5 V

3.3 V

5.0 V

Min.

50 KHz

Max.

160 MHz

12.8 * 12.8 * 6.3

20.2 * 12.8 * 5.8

Applications

- CPU , Graphics , Multimedia A / V clocks
- MPEG / DVD / HDTV clocks
- Laser engine pixel / set - top clocks
- SONET / SDH / ATM clocks
- Fast Ethernet and Gigabit Ethernet clocks
- NTSC / PAL encoder / decoder clocks
- PLL / synthesizer clocks
- Fibre channel and ADSL clocks



General Specifications [Ta = +25°C]

Type	Thru - Hole type				
Model (Dimensions)	H8 (12.8 * 12.8 * 6.3 mm)		H14 (20.2 * 12.8 * 5.8 mm)		
Supply Voltage (V _{DD})	+ 1.8 V ± 10%	+ 2.5 V ± 10%	+ 3.3 V ± 10%	+ 5.0 V ± 10%	
	code is " 18 "	code is " 25 "	code is " 3 "	code is " 5 "	
Frequency Range	0.05 ~ 160 MHz	0.05 ~ 160 MHz	0.05 ~ 160 MHz	0.05 ~ 135 MHz	
Output Logic " High " , " 1 "	1.62 V (min.)	2.25 V (min.)	2.97 V (min.)	4.5 V (min.)	
Output Logic " Low " , " 0 "	0.18 V (max.)	0.25 V (max.)	0.33 V (max.)	0.5 V (max.)	
Current Consumption	< 25 MHz	5 mA (max.)	5 mA (max.)	5 mA (max.)	
	50 MHz	8 mA (max.)	10 mA (max.)	16 mA (max.)	
	100 MHz	10 mA (max.)	15 mA (max.)	30 mA (max.)	
	160 MHz	15 mA (max.)	20 mA (max.)	40 mA (max.)	
Disable Current	10 uA (max.) at OE ≤ 0.3V				
Frequency Stability Codes	Frequency Stability over Operating Temperature Range	± 25 ppm	± 50 ppm	± 100 ppm	If non-standard , please enter the desired stability after the " C " or " F " For example : " C20 " ± 20 ppm over -20°C to +70°C ; " F30 " ± 30 ppm over -40°C to +85°C
	Commercial (-20°C to +70°C)	A	B	C	
	Industrial (-40°C to +85°C)	D	E	F	
Output Load	15 pF (max.) ; 30 pF load for frequencies up to 70 MHz ; Contact Mercury for 50 pF load				
Rise Time (Tr)	10 nsec.(max.) ; 3 nsec.(typ.) . Measured between 10% to 90% waveform (CL=15pF)				
Fall Time (Tf)	10 nsec.(max.) ; 3 nsec.(typ.) . Measured between 10% to 90% waveform (CL=15pF)				
Duty Cycle	50% ± 10 % of waveform [50% ± 5% is also available , add " S " at the end of the part number]				
Start - Up Time	10 msec. (max.) ; 5 msec. (typ.)				
Storage Temperature	-55°C to +125°C				
Aging at Ta=+25°C	± 5.0 ppm per year (max.)				
Output Enable / Disable Function on pin1	70% of V _{DD} (min.) to enable output.				
	30% of V _{DD} (max.) to disable output.				
	Add " T " in part number for OE option				

Outline Dimensions (Unit : mm) , Suggested pad Layout for SMDs

[H8 ; H_8]	[H14 ; H_14]
<p>Top View: 12.8 ± 0.2 x 12.8 ± 0.2 mm, MEC, 10.8 mm diameter, 0.8 mm height, Ø0.45 mm hole, 5.5 mm max. height.</p> <p>Side View: 6.3 ± 0.2 mm height, 0.8 mm thickness, Ø0.45 mm hole, 5.5 mm max. height.</p> <p>Bottom View: 3-Ø1.6 glass stand-off, Pin Connections: Pin1: (1) No connection (2) OE, Pin4: Ground, Pin5: Output, Pin8: Supply voltage.</p>	<p>Top View: 20.2 ± 0.2 x 12.8 ± 0.2 mm, MEC, 10.7 mm diameter, 0.8 mm height, Ø0.45 mm hole, 6.3 mm max. height.</p> <p>Side View: 5.8 ± 0.2 mm height, 0.8 mm thickness, Ø0.45 mm hole, 6.3 mm max. height.</p> <p>Bottom View: 4-Ø1.8 glass stand-off, Pin Connections: Pin 1: (1) No connection (2) Output disabled when low, Pin 7: Ground, Pin 8: Output, Pin 14: Supply voltage.</p>

HA __

32.768 KHz

uA Current Consumption

SMD

CMOS

1.8 V

2.5 V

3.3 V

5.0 V

Min.

27.3 KHz

Max.

100.0 KHz

Features

- Features an AT-Cut crystal for high frequency stability, while providing a low micro Amp (μ A) current consumption that would normally only be available from an X-Cut tuning fork crystal
- 32.768 KHz is popular for Real Time Clocks and other timing applications
- For even tighter frequency stability (± 5 ppm over -40 to 85 °C) and lower current consumption (1.2 μ A at 3.3V) , please contact Mercury

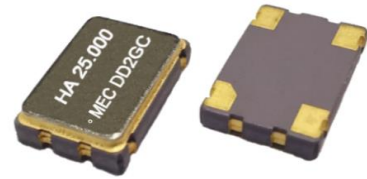

General specifications of all available packages , at Ta=+25°C , CL=15pF

Type	" HA " series [SMD Type]				
Model	HA22	HA32	HA53	HA57	
Dimensions	2.5 * 2.0 * 0.9 mm	3.2 * 2.5 * 1.0 mm	5.0 * 3.2 * 1.2 mm	7.0 * 5.0 * 1.4 mm	
Frequency Output Range	32.768 KHz (standard)				
	27.3 KHz ~ 100 KHz	27.3 KHz ~ 100 KHz	27.3 KHz ~ 100 KHz	27.3 KHz ~ 52 KHz	
Supply Voltage	1.8 V \pm 10% Voltage code is " 18 "	2.5 V \pm 10% Voltage code is " 25 "	3.3 V \pm 10% Voltage code is " 3 "	5.0 V \pm 10% Voltage code is " 5 "	
Current Consumption (32.768 KHz , Load 15pF)	32 μ A (typ.) 50 μ A (max.)	32 μ A (typ.) 50 μ A (max.)	33 μ A (typ.) 50 μ A (max.)	36 μ A (typ.) 60 μ A (max.)	
Output Logic " High " , " 1 "	1.62 V (min.)	2.25 V (min.)	2.97 V (min.)	4.5 V (min.)	
Output Logic " Low " , " 0 "	0.18 V (max.)	0.25 V (max.)	0.33 V (max.)	0.5 V (max.)	
Rise Time (Tr) / Fall Time (Tf) (10 % \longleftrightarrow 90 % waveform)	20 nsec (max.)	20 nsec (max.)	12 nsec (max.)	12 nsec (max.)	
Frequency Stability Codes	Frequency Stability over Operating Temperature Range	± 25 ppm	± 50 ppm	± 100 ppm	If non-standard , please enter the desired stability after the " C " or " F " For example : " C20 " ± 20 ppm over -20 °C to $+70$ °C ; " F30 " ± 30 ppm over -40 °C to $+85$ °C
	Commercial (-20 °C to $+70$ °C)	A	B	C	
	Industrial (-40 °C to $+85$ °C)	D	E	F	
Output Load	15 pF				
Start-up Time	1.0 msec. (typ.) ; 5.0 msec. (max.)				
Duty Cycle	50% \pm 5%				
Output Enable / Disable Function	70% of V _{DD} (min.) to enable output. 30% of V _{DD} (max.) to disable output. Disable current : 3 μ A (max.) for OE \leq 0.3V				
Storage Temperature	-55 °C to $+125$ °C				
Aging at Ta=+25°C	± 3 ppm (max.) first year ; ± 2 ppm (max.) per year thereafter				

HEA _ _

32.768 KHz

Ultra Low Current Consumption

SMD

CMOS

15pF

1.8 V

2.5 V

3.3 V

Features

- Suitable for wearable devices, clock counting use.
- Small package size for 2.5 x 2.0 mm
- If you require products with lower current consumption, please contact Mercury.

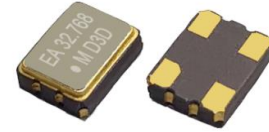

General specifications of all available packages , at Ta=+25°C , CL=15pF

Type	" HEA " series [SMD Type]				
Model	HEA22	HEA32	HEA53	HEA57	
Dimensions	2.5 * 2.0 * 0.9 mm	3.2 * 2.5 * 1.0 mm	5.0 * 3.2 * 1.2 mm	7.0 * 5.0 * 1.4 mm	
Frequency Output	32.768 KHz				
Supply Voltage	1.8 V ± 10% Voltage code is " 18 "	2.5 V ± 10% Voltage code is " 25 "	3.3 V ± 10% Voltage code is " 3 "		
Current Consumption (32.768 KHz , No Load)	6 uA (typ.) 10 uA (max.)	6 uA (typ.) 10 uA (max.)	6 uA (typ.) 10 uA (max.)		
Output Logic " High " , " 1 "	1.62 V (min.)	2.25 V (min.)	2.97 V (min.)		
Output Logic " Low " , " 0 "	0.18 V (max.)	0.25 V (max.)	0.33 V (max.)		
Rise Time (Tr) / Fall Time (Tf) (10 % ↔ 90 % waveform)	7 nsec (typ.) 20 nsec (max.)	7 nsec (typ.) 20 nsec (max.)	6 nsec (typ.) 20 nsec (max.)		
Frequency Stability Codes	Frequency Stability over Operating Temperature Range	± 25 ppm	± 50 ppm	± 100 ppm	If non-standard , please enter the desired stability after the " C " or " F " For example : " C20 " ± 20 ppm over -20°C to +70°C ; " F30 " ± 30 ppm over -40°C to +85°C
	Commercial (-20°C to +70°C)	A	B	C	
	Industrial (-40°C to +85°C)	D	E	F	
Output Load	15 pF				
Start-up Time	5.0 msec. (typ.) ; 10.0 msec. (max.)				
Duty Cycle	50% ± 5%				
Output Enable / Disable Function	70% of V _{DD} (min.) to enable output.				
	30% of V _{DD} (max.) to disable output.				
	Disable current : 5 uA (max.) for OE = GND				
Storage Temperature	-55°C to +150°C				
Aging at Ta=+25°C	± 3 ppm (max.) first year ; ± 2 ppm (max.) per year thereafter				

Low Supply Voltage Crystal Oscillators

CMOS Output

HU _ _

Low Supply Voltage

SMD

CMOS

1.0 V

1.2 V

Min.
0.625 MHz

Max.
50 MHz

Features

- Low 1.0V to 1.2V supply voltage
- Low current consumption
- 2.5 x 2.0 mm small size package

General specifications of all available packages , at Ta=+25°C , CL=15pF

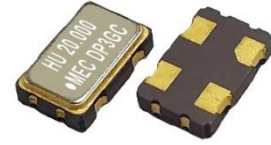

Oscillators

Model [Output Logic]	" HU " series [CMOS]								
Type	HU22			HU32			HU53		HU57
Dimensions	2.5 * 2.0 * 0.9 mm			3.2 * 2.5 * 1.0 mm			5.0 * 3.2 * 1.2 mm		7.0 * 5.0 * 1.4 mm
Frequency Range	0.625 ~ 50.0 MHz								
Supply Voltage (V _{DD})	+1.0 V ± 5%						+1.2 V ± 5%		
	Voltage code is " 10 "						Voltage code is " 12 "		
Current Consumption	1.0 mA (typ.) ; 3.0 mA (max.)						1.3 mA (typ.) ; 3.0 mA (max.)		
Current With Output Disable	10 uA (max.)						10 uA (max.)		
Output Logic " High " , " 1 "	0.8 V (min.)						0.96 V (min.)		
Output Logic " Low " , " 0 "	0.2 V (max.)						0.24 V (max.)		
Rise Time (Tr) / Fall Time (Tf)	8.0 nsec. (max.)						6.0 nsec. (max.)		
	Measured between 20 % ↔ 80 % of V _{DD}								
Frequency Stability Codes	Frequency Stability over	± 25 ppm		± 50 ppm		± 100 ppm		If non-standard , please enter the desired stability after the " C " or " F " For example : " C20 " ± 20 ppm over -20°C to +70°C ; " F30 " ± 30 ppm over -40°C to +85°C	
	Operating Temperature Range								
	Commercial (-20°C to +70°C)	A		B		C			
	Industrial (-40°C to +85°C)	D		E		F			
Supply Voltage vs Freq. Sensitivity	± 1.0 ppm (max.)								
Output Load	15 pF								
Start-up Time	0.8 msec (typ.) ; 5.0 msec (max.)								
Duty Cycle	50% ± 5%								
Output Enable / Disable Function on pin1	70% of V _{DD} (min.) to enable output.								
	30% of V _{DD} (max.) to disable output.								
Enable / Disable Time	Enable : 5.0 msec. (max.)								
	Disable : 100 nsec. (max.)								
Storage Temperature	-55°C to +150°C								
Aging at Ta=+25°C	± 3 ppm (max.) first year								
RMS Jitter [12 kHz ~ 20 MHz]	0.75 ps (typ.)								
SSB Phase Noise	Offset	10 Hz	100 Hz	1 KHz	10 KHz	100 KHz	1 MHz	5 MHz	20 MHz
25.000MHz [1.0V]	dBc/Hz (typ.)	-75	-107	-128	-138	-141	-149	-153	---
50.000MHz [1.2V]	dBc/Hz (typ.)	-83	-112	-136	-140	-147	-155	-155	-156

HY --

Wide Operating Temperature

Over -40 °C to +125 °C

SMD

CMOS

1.8 V

2.5 V

3.3 V

Min.

1.25 MHz

Max.

50.0 MHz

Features

- Femtosecond RMS phase jitter. 150 fs typical (12 KHz ~ 5 MHz)
- Superior phase noise: -155 dBc/Hz at 10 KHz and -160 dBc/Hz at 100 KHz offset
- Wide Operating Temperature range from -40 °C to +125 °C

General specifications of all available packages , at Ta=+25°C , CL=15pF

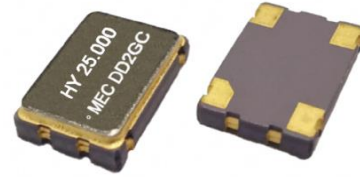

Model [Output Logic]		" HY " series [CMOS]						
Type		HY22	HY32	HY53	HY57			
Dimensions		2.5 * 2.0 * 0.9 mm	3.2 * 2.5 * 1.0 mm	5.0 * 3.2 * 1.2 mm	7.0 * 5.0 * 1.4 mm			
Available Frequency Range		1.25 ~ 50.0 MHz						
Supply Voltage (V _{DD})		+1.8 V ± 10%	+2.5 V ± 10%			+3.3 V ± 10%		
Supply Voltage Code		" 18 "	" 25 "			" 3 "		
Current Consumption [15pF load]	1.25 ~ 19.99 MHz	2.0 mA (max.)	3.0 mA (max.)			4.0 mA (max.)		
	20.0 ~ 50.00 MHz	4.0 mA (max.)	5.0 mA (max.)			6.0 mA (max.)		
Frequency Stability Codes		Frequency Stability over	± 25 ppm	± 50 ppm	± 100 ppm	If non-standard , please enter the desired stability after the " K " For example : " K40 " ± 40 ppm over -40°C to +125°C		
		Car Grade (-40°C to +125°C)	---	K50	K100			
Rise Time (Tr) / Fall Time (Tf)		10 nsec. (max.)						
		Measured between 10% ↔ 90% of waveform (CL = 15pF)						
Output Load		15 pF						
Start-up Time		5.0 msec. (max.)						
Duty Cycle		Standard: 50% ± 10% ; Option: 50% ± 5%. Please add "-S" at the end of the part number for ± 5% .						
Output Enable / Disable Function		70% of V _{DD} (min.) to Enable Output.						
		30% of V _{DD} (max.) to Disable Output.						
Phase Jitter (RMS) [26 MHz , 3.3V]		150 fsec (typ.) [12 KHz to 5 MHz integrated]						
SSB Phase Noise [26 MHz , 3.3V]	Offset	10 Hz	100 Hz	1 KHz	10 KHz	100KHz	1 MHz	5 MHz
	dBc / Hz (typ.)	-94	-127	-142	-156	-161	-163	-163
Storage Temperature		-65°C to +150°C						
Aging at Ta=+25°C		± 2 ppm (max.) for first year						

3225 HY-series 25.000MHz Refer at 25°C

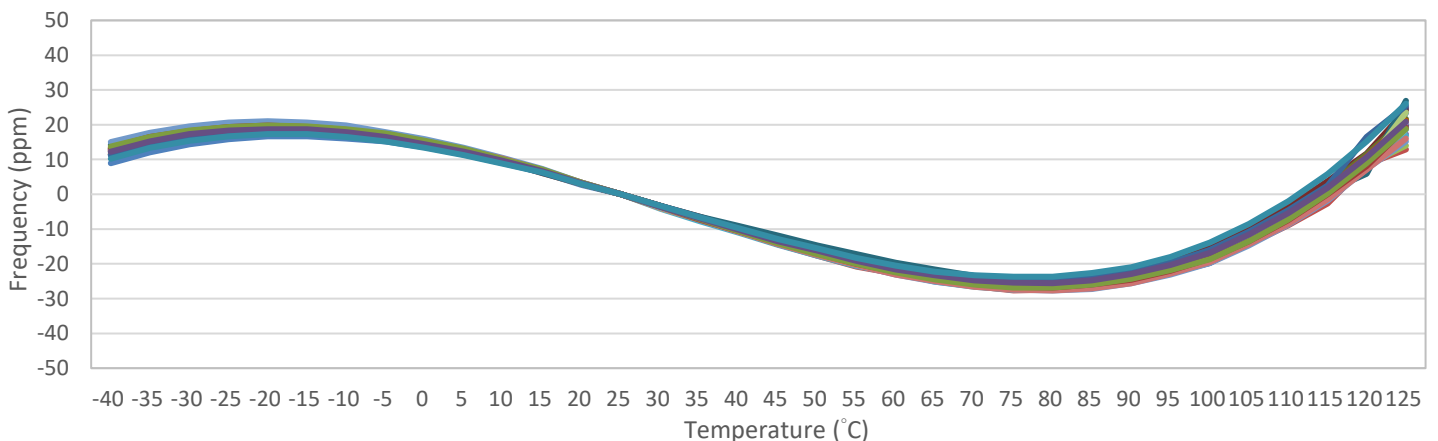

Outline Dimensions (Unit : mm) , Suggested pad Layout for SMDs

Oscillators

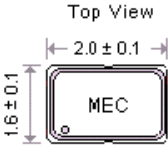
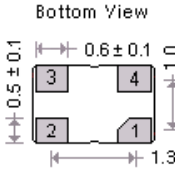
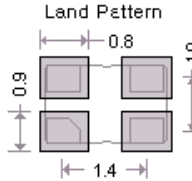
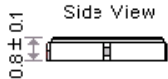
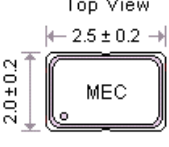
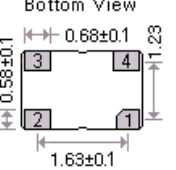
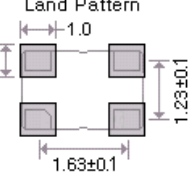
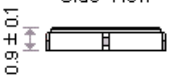
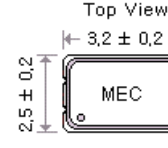
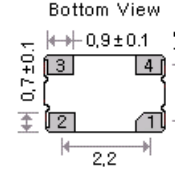
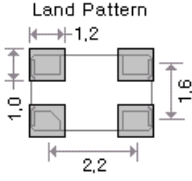
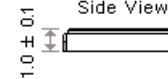
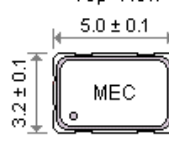
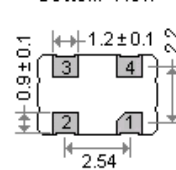
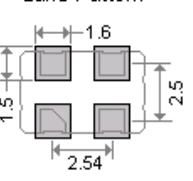
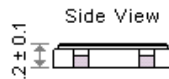
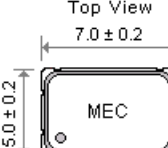
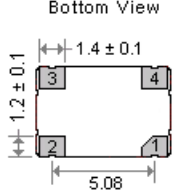
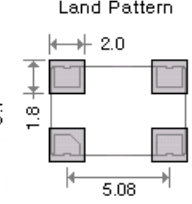
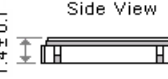
[H21]	[H22 ; H_22]
    <p>Pad Connections : Pad 1 : OE Pad 3 : Output Pad 2 : Ground Pad 4 : Supply Voltage</p>	    <p>Pad Connections : Pad 1 : OE Pad 3 : Output Pad 2 : Ground Pad 4 : Supply Voltage</p>
[H32 ; H_32]	[H53 ; H_53]
    <p>Pad Connections : Pad 1 : OE Pad 3 : Output Pad 2 : Ground Pad 4 : Supply Voltage</p>	    <p>Pad Connections : Pad 1 : OE Pad 3 : Output Pad 2 : Ground Pad 4 : Supply Voltage</p>
[SWO ; H_57]	
    <p>Pad Connections : Pad 1 : OE Pad 3 : Output Pad 2 : Ground Pad 4 : Supply Voltage</p>	

Part Number Format and Examples

	[1]	[2]	-	[3]	[4]	-	[5]	
	Supply Voltage	Holder Type		Frequency Stability	OE Function		Center Frequency	
Examples	(1)	3	SWO	-	D	T	-	25.000
	(2)	3	HY32	-	K50	T	-	24.000
	(3)	18	HA32	-	B	T	-	32.768K
	(4)	3	H22	-	E	T	-	49.152

Ex (1): 3SWO - DT - 25.000 [3.3V , H seires 7050 type , ±25ppm from -40°C to +85°C , OE Function , 25.000MHz]

Ex (2): 3HY32 - K50T - 24.000 [3.3V , HY seires 3225 type , ±50ppm from -40°C to +125°C , OE Function , 24.000MHz]

Ex (3): 18HA32 - BT - 32.768K [1.8V , HA seires 3225 type , ±50ppm from -20°C to +70°C , OE Function , 32.768KHz]

Ex (4): 3H22 - ET - 49.152 [3.3V , H seires 2520 type , ±50ppm from -40°C to +85°C , OE Function , 49.152 MHz]

[1]	Supply voltage " 10 " for +1.0V ; " 12 " for +1.2V ; " 18 " for +1.8V ; " 25 " for +2.5V ; " 3 " for +3.3V ; " 5 " for +5.0V	
[2]	Holder Type	
[3]	-20°C ~ 70°C	" A " ± 25ppm ; " B " ± 50ppm ; " C " ± 100ppm ; If non-standard please enter the desired stability after " C " , example " C15 " : represents ±15ppm over -20 to +70°C
	-40°C ~ 85°C	" D " ± 25ppm ; " E " ± 50ppm ; " F " ± 100ppm ; If non-standard please enter the desired stability after " F " , example " F30 " : represents ± 30ppm over -40 to +85°C
[4]	" T " for OE Function , Leave this space blank if no connection on pad 1.	
[5]	Frequency in MHz	

Test Circuit & Test Waveform

H ; H₋ - series CMOS Test Circuit

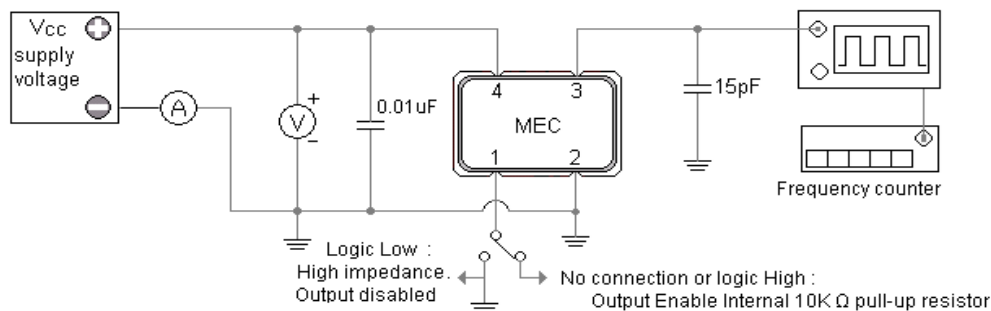

CMOS Output Waveform

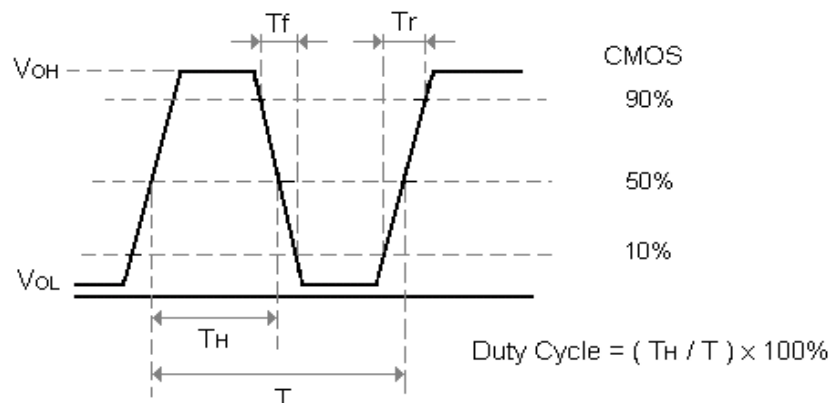

HJN _ _

Ultra Low Jitter

SMD

CMOS

1.8 V

2.5 V

3.3 V

Min.

0.625 MHz

Max.

60 MHz

Features

- The HJN series is Low jitter crystal oscillators.
- Compared with standard oscillator, Mercury's HJN series has much better phase noise and jitter. HJN series with output frequency 49.152MHz has phase jitter 57 fsec (RMS, 12 KHz to 20 MHz) when V_{DD} at 3.3V.

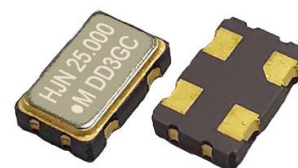
General specifications of all available packages , at $T_a=+25^{\circ}\text{C}$, $CL=15\text{pF}$

Model [Output Logic] " HJN " series [CMOS]

Type	HJN22	HJN32	HJN53	HJN57
Dimensions	2.5 * 2.0 * 0.9 mm	3.2 * 2.5 * 1.0 mm	5.0 * 3.2 * 1.2 mm	7.0 * 5.0 * 1.4 mm

Supply Voltage (V_{DD})	1.8 V \pm 10% Voltage code is " 18 "	2.5 V \pm 10% Voltage code is " 25 "	3.3 V \pm 10% Voltage code is " 3 "
Frequency Range	0.625 ~ 50.0 MHz	0.625 ~ 60.0 MHz	0.625 ~ 60.0 MHz
Current Consumption	2 mA (typ.) ; 5 mA (max.)	3 mA (typ.) ; 7 mA (max.)	5 mA (typ.) ; 10 mA (max.)
Current With Output Disable	20 μ A (max.)	20 μ A (max.)	20 μ A (max.)
Output Logic " High " , " 1 "	1.62 V (min.)	2.25 V (min.)	2.97 V (min.)
Output Logic " Low " , " 0 "	0.18 V (max.)	0.25 V (max.)	0.33 V (max.)
Rise Time (T_r) / Fall Time (T_f) (10 % \longleftrightarrow 90 % waveform)	2.0 nsec. (typ.) 5.0 nsec. (max.)	1.0 nsec. (typ.) 4.0 nsec. (max.)	1.0 nsec. (typ.) 3.0 nsec. (max.)

Frequency Stability Codes	Frequency Stability over Operating Temperature Range	\pm 25 ppm	\pm 50 ppm	\pm 100 ppm	If non-standard , please enter the desired stability after the " C " ; " F " ; " J " represents . For example : " C20 " \pm 20 ppm over -20°C to $+70^{\circ}\text{C}$; " F30 " \pm 30 ppm over -40°C to $+85^{\circ}\text{C}$; " J40 " \pm 40 ppm over -40°C to $+105^{\circ}\text{C}$
	Commercial (-20°C to $+70^{\circ}\text{C}$)	A	B	C	
	Industrial (-40°C to $+85^{\circ}\text{C}$)	D	E	F	
	Extended Industrial (-40°C to $+105^{\circ}\text{C}$)	G	H	J	

Output Load	15 pF									
Start-up Time	0.4 msec (typ.) ; 1.0 msec (max.)									
Duty Cycle	50% \pm 5%									
Output Enable / Disable Function on pin1	70% of V_{DD} (min.) to enable output.									
	30% of V_{DD} (max.) to disable output.									
Enable / Disable Time	Enable : 1.0 msec. (max.)									
	Disable : 200 nsec. (max.)									
Storage Temperature	-55°C to $+150^{\circ}\text{C}$									
Aging at $T_a=+25^{\circ}\text{C}$	\pm 3 ppm (max.) first year									
RMS Jitter [12 kHz ~ 20 MHz]	57 fsec (typ.) @ 3.3V , 49.152MHz									
SSB Phase Noise	Offset	10 Hz	100 Hz	1 KHz	10 KHz	100 KHz	1 MHz	5 MHz	20 MHz	
	24.000MHz [3.3V]	dBc/Hz (typ.)	-78	-111	-142	-154	-167	-171	-171	---
	49.152MHz [3.3V]	dBc/Hz (typ.)	-83	-113	-137	-151	-166	-171	-171	-171

Part Number Format and Examples

[1]	[2]	-	[3]	[4]	-	[5]
Supply Voltage	Holder Type		Frequency Stability	OE Function		Center Frequency

Examples	(1)	(2)	(3)	(4)	(5)	
	18	HJN57	-	D	T	25.000
	25	HJN32	-	A	T	24.000
	3	HJN22	-	H	T	32.000

- Ex (1) : 18HJN57 - DT - 25.000 [1.8V, HJN series 7050 type, ±25ppm from -40°C to +85°C, OE Function, 25.000MHz]
 Ex (2) : 25HJN32 - AT - 24.000 [2.5V, HJN series 3225 type, ±25ppm from -20°C to +70°C, OE Function, 24.000MHz]
 Ex (3) : 3HJN22 - HT - 32.000 [3.3V, HJN series 2520 type, ±50ppm from -40°C to +105°C, OE Function, 32.000MHz]

[1]	Supply voltage " 18 " for +1.8V ; " 25 " for +2.5V ; " 3 " for +3.3V
[2]	Holder Type
[3]	-20°C ~ 70°C " A " ± 25ppm ; " B " ± 50ppm ; " C " ± 100ppm ; If non-standard please enter the desired stability after " C ", for example " C15 " : represents ±15ppm over -20 to +70°C
	-40°C ~ 85°C " D " ± 25ppm ; " E " ± 50ppm ; " F " ± 100ppm ; If non-standard please enter the desired stability after " F ", for example " F30 " : represents ±30ppm over -40 to +85°C
	-40°C ~ 105°C " G " ± 25ppm ; " H " ± 50ppm ; " J " ± 100ppm ; If non-standard please enter the desired stability after " J ", for example " J40 " : represents ±40ppm over -40 to +105°C
[4]	" T " for OE Function , Leave this space blank if no connection on pad 1.
[5]	Frequency in MHz

Outline Dimensions (Unit : mm) , Suggested pad Layout for SMDs

[HJN22]	[HJN32]

Test Circuit & Test Waveform

H ; H₋ - series CMOS Test Circuit

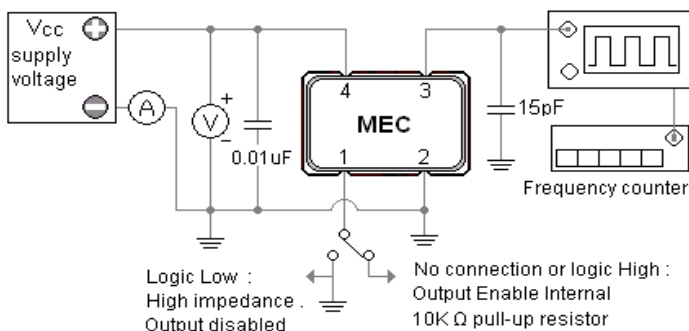

CMOS Output Waveform

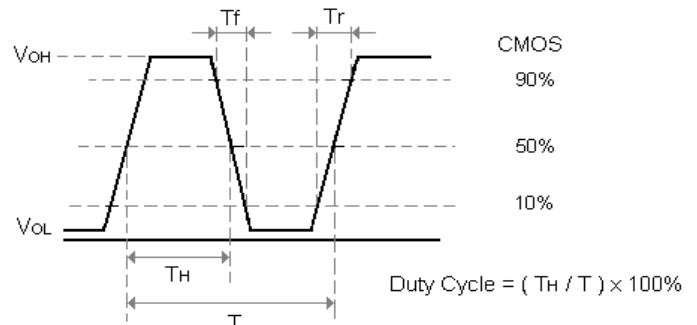

Crystal Oscillators [Programmable Quick Turn]

HTF --

**Quick - Turn
Clock Oscillators**

SMD

CMOS

1.8 V

2.5 V

3.3 V

**Min.
1.0 MHz**

**Max.
200 MHz**

Features

- Short lead time. From 1 day to 1 week
- Low jitter , RMS jitter is 0.9 ps typical
- Custom frequencies can easily be configured
- 1.8V, 2.5V or 3.3V supply voltages.

0.9 ps Phase Jitter (typical)

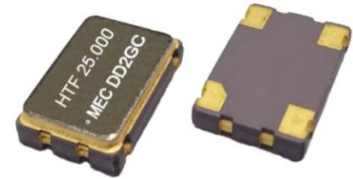

General specifications of all available packages , at Ta=+25°C , CL=15pF

Oscillators

Model [Output Logic]	" HTF " series [CMOS]									
Type	HTF21		HTF22		HTF32		HTF53		HTF57	
Dimensions	2.0 * 1.6 * 0.8 mm		2.5 * 2.0 * 0.8 mm		3.2 * 2.5 * 1.0 mm		5.0 * 3.2 * 1.2 mm		7.0 * 5.0 * 1.3 mm	
Supply Voltage (V _{DD})	+1.8 V ± 5%		+2.5 V ± 10%		+2.5 V ± 10%		+3.3 V ± 10%			
Available Frequency Range	1.0 ~ 125.0 MHz		1.0 ~ 200.0 MHz		1.0 ~ 200.0 MHz		1.0 ~ 200.0 MHz			
Current Consumption	20 mA (typ.) 30 mA (max.)		28 mA (typ.) 35 mA (max.)		28 mA (typ.) 35 mA (max.)		30 mA (typ.) 40 mA (max.)			
Rise Time (Tr) / Fall Time (Tf) 10% ↔ 90% Waveform	2.0 ns (typ.) 5.0 ns (max.)		1.4 ns (typ.) 3.0 ns (max.)		1.4 ns (typ.) 3.0 ns (max.)		1.1 ns (typ.) 3.0 ns (max.)			
Frequency Stability Codes	Frequency Stability over Operating Temperature Range		± 25 ppm	± 50 ppm	± 100 ppm	If non-standard , please enter the desired stability after the " C " or " F " represents. For example : " C20 " ± 20 ppm over -20°C to +70°C ; " F30 " ± 30 ppm over -40°C to +85°C				
	Commercial (-20°C to +70°C)		A	B	C					
	Industrial (-40°C to +85°C)		D	E	F					
Output Logic " High " , " 1 "	V _{DD} - 0.4V (min.)									
Output Logic " Low " , " 0 "	0.4V (max.)									
Duty Cycle	1 MHz to 150 MHz : 50% ± 5% 151 MHz to 200 MHz : 50% ± 10%									
Output Load	15 pF									
Start-up Time	4.5 msec (typ.) ; 10 msec (max.)									
Storage Temperature	-55°C to +150°C									
Aging at Ta=+25°C	± 3 ppm (max.) first year ; ± 2 ppm (max.) per year thereafter									
SSB Phase Noise	Offset	10 Hz	100 Hz	1 kHz	10 kHz	100 kHz	1 MHz	10 MHz		
125.000 MHz @ 3.3 V	dBc/Hz	-61	-89	-110	-119	-119	-142	-149		
RMS Jitter (12kHz ~ 20 MHz)	0.9 psec (typ.)									
Output Enable / Disable Function										
Output Enable / Disable		70% of V _{DD} (min.) to Enable. 30% of V _{DD} (max.) to Disable.								
Pad 1 Options	Power Down Mode (code : PD)	Disable Current : 300 uA (typ.) ; 400 uA (max.) Output Enable Time : 4.5 msec (typ.) ; 10 msec (max.)								
	OE Mode. High Enable (code : OE)	Disable Current : 18 mA (typ.) ; 22 mA (max.) Output Enable Time : 10 nsec (max.)								

Crystal Oscillators [Programmable Quick Turn]

HTF --

**Quick - Turn
Clock Oscillators**

SMD

CMOS

1.8 V

2.5 V

3.3 V

**Min.
1.0 MHz**

**Max.
200 MHz**

Part Number Format and Examples

0.9 ps Phase Jitter (typical)

	[1]	[2]	-	[3]	[4]	-	[5]	-	[6]		
	Supply Voltage	Holder Type	-	Frequency Stability	T	-	Center Frequency	-	Disable Options		
Examples	(1)	18		HTF57	-	B	T	-	25.000	-	PD
	(2)	25		HTF53	-	C30	T	-	100.000	-	OE
	(3)	3		HTF32	-	E	T	-	200.000	-	PD

Ex (1) : 18HTF57 - BT - 25.000 - PD [1.8V , HTF57 type , ±50ppm @ -20°C to +70°C , E/D , 25.000MHz , Power Down Mode]

Ex (2) : 25HTF53 - C30T - 100.000 - OE [2.5V , HTF53 type , ±30ppm @ -20°C to +70°C , E/D , 100.000MHz , OE Mode]

Ex (3) : 3HTF32 - ET - 200.000 - PD [3.3V , HTF32 type , ±50ppm @ -40°C to +85°C , E/D , 200.000MHz , Power Down Mode]

[1]	Supply voltage , " 18 " for +1.8V ; " 25 " for +2.5V ; " 3 " for +3.3V
[2]	Holder Type
[3]	-20°C ~ 70°C " A " ± 25ppm ; " B " ± 50ppm ; " C " ± 100ppm ; If non-standard please enter the desired stability after " C " ; example " C15 " : represents ±15ppm over -20 to +70°C
	-40°C ~ 85°C " D " ± 25ppm ; " E " ± 50ppm ; " F " ± 100ppm ; If non-standard please enter the desired stability after " F " ; example " F30 " : represents ± 30ppm over -40 to +85°C
[4]	" T " for Output Enable/Disable Function
[5]	Frequency in MHz
[6]	Pad 1 Options , " PD " Power Down Mode ; " OE " OE Mode. High Enable

Outline Dimensions (Unit : mm) , Suggested pad Layout for SMDs

HTF21	HTF22
HTF32	HTF53
HTF57	

Differential Crystal Oscillators with No PLL

Differential

HPK LVPECL Differential	HDK LVDS Differential	HCK HCSL Differential	HCLK LPHCSL Differential	SMD	1.8 V	2.5 V	3.3 V	Min. 13.5 MHz	Max. 220 MHz
-----------------------------------	---------------------------------	---------------------------------	------------------------------------	-----	-------	-------	-------	------------------	-----------------

Features

Jitter 0.2 pS (typical)

- Femtosecond integrated phase jitter (200 fs (typ.) , 12 KHz to 20 MHz)
- Superior phase noise (-138 dBc/Hz at 10 KHz and -144 dBc/Hz at 100 KHz offset)

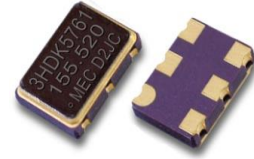

General specifications , at Ta=+25°C

Model	HPK	HDK	HCK	HCLK
Output Logic	LVPECL	LVDS	HCSL	LPHCSL
Package (dimensions) unit : mm	HPK2261 (2.5 * 2.0 * 1.0) HPK3261 (3.2 * 2.5 * 1.0) HPK5361 (5.0 * 3.2 * 1.2) HPK5761 (7.0 * 5.0 * 1.7)	HDK2261 (2.5 * 2.0 * 1.0) HDK3261 (3.2 * 2.5 * 1.0) HDK5361 (5.0 * 3.2 * 1.2) HDK5761 (7.0 * 5.0 * 1.7)	HCK2261 (2.5 * 2.0 * 1.0) HCK3261 (3.2 * 2.5 * 1.0) HCK5361 (5.0 * 3.2 * 1.2) HCK5761 (7.0 * 5.0 * 1.7)	HCLK2261 (2.5 * 2.0 * 1.0) HCLK3261 (3.2 * 2.5 * 1.0) HCLK5361 (5.0 * 3.2 * 1.2) HCLK5761 (7.0 * 5.0 * 1.7)
Available Frequency Range	13.5 MHz ~ 220 MHz	13.5 MHz ~ 220 MHz	13.5 MHz ~ 220 MHz	95 MHz ~ 180.0 MHz
Supply Voltage (V _{DD})	--	+1.8 V ± 5%	+1.8 V ± 5%	+1.8 V ± 5%
	+2.5 V ± 5%	+2.5 V ± 5%	+2.5 V ± 5%	+2.5 V ± 5%
	+3.3 V ± 10%	+3.3 V ± 10%	+3.3 V ± 10%	+3.3 V ± 10%
Current Consumption (V _{DD} = + 3.3V)	30 mA (typ.) 50 mA (max.)	16 mA (typ.) 27 mA (max.)	17 mA (typ.) 30 mA (max.)	11 mA (typ.) 20 mA (max.)
Output Logic " High " , " 1 "	V _{DD} - 1.03 (min.) V _{DD} - 0.6 (max.)	1.4 V (typ.) 1.6 V (max.)	550 mV (min.) 850 mV (max.)	550 mV (min.) 900 mV (max.)
Output Logic " Low " , " 0 "	V _{DD} - 1.85 (min.) V _{DD} - 1.6 (max.)	0.9 V (min.) 1.1 V (typ.)	-150 mV (min.) 150 mV (max.)	-150 mV (min.) 150 mV (max.)
Rise Time / Fall Time (20%↔80% of waveform)	0.3 nsec. (typ.) 0.6 nsec. (max.)	0.3 nsec. (typ.) 0.5 nsec. (max.)	0.3 nsec. (typ.) 0.6 nsec. (max.)	0.4 nsec. (typ.) 0.7 nsec. (max.)
Output Voltage Swing	595 mV (min.) , 750 mV (typ.) , 930 mV (max.)	250 mV (min.) , 350 mV (typ.) , 450 mV (max.)	400 mV (min.)	550 mV (min.)
Output Load	50 Ω into V _{CC} - 2V or Thevenin equivalent	100 Ω between output and complimentary output	50 Ω to ground on each output	None

Start-up Time	5.0 msec. (typ.) , 10 msec. (max.)						
Duty Cycle	50% ± 5%						
Storage Temperature	-55°C to +150°C						
Aging at Ta = +25°C	± 3 ppm (max.) first year ; ± 2 ppm (max.) per year thereafter						
RMS Jitter (12 KHz to 20 MHz)	0.2 psec (typ.) ; 0.5 psec (max.) [For 156.250 MHz] ; 0.18 psec (typ.) [For HCLK]						
SSB Phase Noise [dBc / Hz (typ.)]	Offset	10 Hz	100 Hz	1 KHz	10 KHz	100 KHz	1 MHz
	62.5 MHz	-50	-82	-116	-138	-144	-149
	156.250 MHz	-50	-80	-115	-135	-142	-147
Frequency Stability Codes	Frequency Stability over Operating Temperature Range		± 25 ppm	± 50 ppm	± 100 ppm	If non-standard , please enter the desired stability after the " C " or " F " represents . For example : " C20 " ± 20 ppm over -20°C to +70°C ; " F30 " ± 30 ppm over -40°C to +85°C	
	Commercial (-20°C to +70°C)		A	B	C		
	Industrial (-40°C to +85°C)		D	E	F		
Output Enable / Disable Function	Enable	When 70% min. of V _{DD} to Enable Output. Enable time : 10 msec (max.)					
	Disable	When 30% max. of V _{DD} to Disable Output. Disable current : 10 uA (max.)(OE ≤ 0.3V) , Disable time : 0.2 usec. (max.)					

Superb phase noise differential oscillators

Differential

HPEK

HDEK

HCEK

SMD

2.5 V

3.3 V

Min.

13.5 MHz

Max.

220 MHz

Features

- Noise improved version for H_EK-series
- Femtosecond integrated phase jitter (98 fs typical , 12 KHz to 20 MHz)
- Superior phase noise (-149 dBc/Hz at 100 KHz and -157 dBc/Hz at 10 MHz offset)

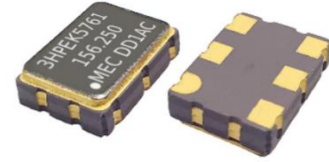

General specifications , at Ta=+25°C

Model	HPEK	HDEK	HCEK
Output Logic	LVPECL	LVDS	HCSL
Available Frequency Range	13.5 MHz ~ 60 MHz 90 MHz ~ 220 MHz	13.5 MHz ~ 60 MHz 90 MHz ~ 220 MHz	13.5 MHz ~ 60 MHz 90 MHz ~ 220 MHz
Supply Voltage (V _{DD})	---	+ 2.5 V ± 10% + 3.3 V ± 10%	+ 2.5 V ± 10% + 3.3 V ± 10%
Output Load	50 Ω into V _{DD} - 2.0V or Thevenin equivalent	100 Ω between output and complimentary output	50 Ω to ground on each output
Rise Time / Fall Time (20%↔80% of waveform)	0.2 nsec (typ.) 0.4 nsec (max.)	0.2 nsec (typ.) 0.4 nsec (max.)	0.5 nsec (typ.) 0.8 nsec (max.)
Current Consumption	38 mA (typ.) , 60 mA (max.)	15 mA (typ.) , 35 mA (max.)	32 mA (typ.) , 40 mA (max.)
Output Logic " High " , " 1 "	V _{DD} - 1.03 (min.) , V _{DD} - 0.88 (max.)	1.4 V (typ.) , 1.6 V (max.)	0.5 V (min.) , 0.9 V (max.)
Output Logic " Low " , " 0 "	V _{DD} - 1.81 (min.) , V _{DD} - 1.62 (max.)	0.9 V (min.) , 1.1 V (typ.)	- 0.15 V (min.) , 0.15 V (max.)
Output Swing (single-end)	400 mV (min.)	250 mV (min.)	500 mV (min.)

Frequency Stability Codes	Frequency Stability over Operating Temperature Range	± 25 ppm	± 50 ppm	± 100 ppm	If non-standard , please enter the desired stability after the " C " or " F " represents . For example : " C20 " ± 20 ppm over -20°C to +70°C ; " F30 " ± 30 ppm over -40°C to +85°C
	Commercial (-20°C to +70°C)	A	B	C	
	Industrial (-40°C to +85°C)	D	E	F	

Start-up Time	1.0 msec. (typ.) , 5.0 msec (max.)						
Duty Cycle	50% ± 5%						
Storage Temperature	-55°C to +150°C						
Aging at Ta = +25°C	± 3 ppm (max.) first year						
RMS Jitter (12 KHz to 20 MHz)	Freq. output < 100MHz : 350 fsec (typ.) , [50MHz , 3.3V , LVDS]						
	Freq. output > 100MHz : 98 fsec (typ.) , [156.250MHz , 3.3V , LVDS]						
Phase Noise [dBc / Hz (typ.)]	Offset	100 Hz	1 KHz	10 KHz	100 KHz	1 MHz	10 MHz
	50 MHz	-104	-134	-147	-153	-152	-157
	156.250 MHz	-93	-123	-140	-149	-152	-157
Output Enable / Disable Function	Enable	70% (min.) of V _{DD} to enable output. Enable time : 5 msec (max.)					
	Disable	30% (max.) of V _{DD} to disable output. Disable current : 10 uA (max.) [OE ≤ 0.3V] , Disable time : 0.2 usec (max.)					

Ultra Low Jitter Differential Oscillator

Differential

HPJK

LVPECL Differential

HDJK

LVDS Differential

HCJK

HCSL Differential

SMD

1.8 V

2.5 V

3.3 V

Min.

100 MHz

Max.

250 MHz

Features

- Femtosecond integrated phase jitter (50 fs typical , 12 KHz to 20 MHz)
- Superior phase noise (-157 dBc/Hz at 100 KHz and -164 dBc/Hz at 10 MHz offset)
- Small size for 2.5 x 2.0 mm package

Jitter 50 fsec (typical)

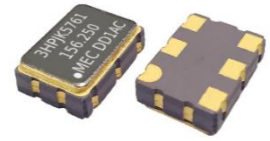

General specifications , at Ta=+25°C

Model		HPJK	HDJK	HCJK			
Output Logic		LVPECL	LVDS	HCSL			
Available Frequency Range by Voltage (V _{DD})	1.8 V ± 5%	--	100 MHz ~ 175 MHz	100 MHz ~ 175 MHz			
	2.5 V ± 10%	100 MHz ~ 250 MHz	100 MHz ~ 250 MHz	100 MHz ~ 175 MHz			
	3.3 V ± 10%	100 MHz ~ 250 MHz	100 MHz ~ 250 MHz	100 MHz ~ 175 MHz			
If you have frequency requirements below 100MHz, please contact Mercury.							
Output Load		50 Ω into V _{DD} - 2.0V or Thevenin equivalent	100 Ω between output and complimentary output	50 Ω to ground on each output			
Rise Time / Fall Time (20%↔80% of waveform)		0.15 nsec (typ.) 0.4 nsec (max.)	0.15 nsec (typ.) 0.3 nsec (max.)	0.2 nsec (typ.) 0.6 nsec (max.)			
Current Consumption		52 mA (typ.) , 65 mA (max.)	22 mA (typ.) , 30 mA (max.)	38 mA (typ.) , 48 mA (max.)			
Output Logic " High " , " 1 "		V _{DD} - 1.085 (min.) , V _{DD} - 0.86 (max.)	1.4 V (typ.) , 1.6 V (max.)	0.55 V (min.) , 1.0 V (max.)			
Output Logic " Low " , " 0 "		V _{DD} - 1.81 (min.) , V _{DD} - 1.62 (max.)	0.9 V (min.) , 1.1 V (typ.)	- 0.15 V (min.) , 0.15 V (max.)			
Output Swing (single-end)		400 mV (min.)	200 mV (min.)	450 mV (min.)			
Frequency Stability Codes	Frequency Stability over Operating Temperature Range	± 25 ppm	± 50 ppm	± 100 ppm	If non-standard , please enter the desired stability after the " C " or " F " represents . For example : " C20 " ± 20 ppm over -20°C to +70°C ; " F30 " ± 30 ppm over -40°C to +85°C		
	Commercial (-20°C to +70°C)	A	B	C			
	Industrial (-40°C to +85°C)	D	E	F			
Start-up Time		1.0 msec. (typ.) , 5.0 msec. (max.)					
Duty Cycle		50% ± 5%					
Storage Temperature		-55°C to +150°C					
Aging at Ta = +25°C		± 3 ppm (max.) first year ; ± 2 ppm (max.) per year thereafter					
RMS Jitter (12 KHz to 20 MHz)		50 fsec (typ.) , 300 fsec (max.) [For 156.250 MHz , LVDS , 3.3V]					
Phase Noise [dBc / Hz (typ.)]	Offset	100 Hz	1 KHz	10 KHz	100 KHz	1 MHz	10 MHz
	125.0 MHz	-114	-135	-147	-157	-163	-164
	156.250 MHz	-108	-132	-141	-152	-160	-161
Output Enable / Disable Function		Enable	70% (min.) of V _{DD} to enable output. Enable time : 10 msec (max.)				
		Disable	30% (max.) of V _{DD} to disable output. Disable current : 30 uA (max.) [OE = GND] , Disable time : 0.2 usec (max.)				

Oscillators

Crystal Oscillators

HP_ [LVPECL Differential] HD_ [LVDS Differential] HC_ [HCSSL Differential] HCL_ [LPHCSL Differential]

Part Number Format and Example

[1]	[2]	[3]	-	[4]	-	[5]
Supply Voltage	Holder Type	1 or 2		Frequency Stability		Center Frequency

Example	(1)	25	HCK536	1	-	C15	-	125.000
	(2)	18	HDJK576	2	-	D	-	156.250

Ex (1) : **25HCK5361 - C15 - 125.000** [+2.5V , HCK type , HCSSL output , 5.0 x 3.2 mm size , OE on pad 1 , ±15 ppm from -20°C to 70°C , 125.000MHz]
 Ex (2) : **18HDJK5762 - D - 156.250** [+1.8V , HDJK type , LVDS output , 7.0 x 5.0 mm size , OE on pad 2 , ±25 ppm from -40°C to 85°C , 156.250MHz]

[1]	Supply voltage , " 18 " for +1.8V ; " 25 " for +2.5V ; " 3 " for +3.3V	
[2]	Holder Type	
[3]	" 1 " : OE function on pad # 1 , " 2 " : OE function on pad # 2	
[4]	-20°C ~ 70°C	" A " ± 25ppm ; " B " ± 50ppm ; " C " ± 100ppm ; If non-standard please enter the desired stability after " C " , for example " C15 " : represents ±15ppm over -20 to +70°C
	-40°C ~ 85°C	" D " ± 25ppm ; " E " ± 50ppm ; " F " ± 100ppm ; If non-standard please enter the desired stability after " F " , for example " F30 " : represents ± 30ppm over -40 to +85°C
[5]	Frequency in MHz	

Outline Dimensions (Unit : mm) , Suggested pad Layout for SMDs , Test Circuits

<p style="text-align: center;">H_K226</p> <p>Pad Connections : Pad 1 : OE Pad 2 : No Connection Pad 3 : Ground Pad 4 : Output Pad 5 : Complementary Pad 6 : Supply Voltage</p>	<p style="text-align: center;">H_K326</p> <p>Pad Connections : Pad 1 : OE Pad 2 : No Connection Pad 3 : Ground Pad 4 : Output Pad 5 : Complementary Pad 6 : Supply Voltage</p>
<p style="text-align: center;">H_K536</p> <p>Pad Connections : Pad 1 : OE Pad 2 : No Connection Pad 3 : Ground Pad 4 : Output Pad 5 : Complementary Pad 6 : Supply Voltage</p>	<p style="text-align: center;">H_K576</p> <p>Pad Connections : Pad 1 : OE Pad 2 : No Connection Pad 3 : Ground Pad 4 : Output Pad 5 : Complementary Pad 6 : Supply Voltage</p>
<p style="text-align: center;">LVPECL Test Circuit</p> <p>$V_{DD} = 3.3V ; R_1 = R_3 = 127 \Omega ; R_2 = R_4 = 82.5 \Omega$ $V_{DD} = 2.5V ; R_1 = R_3 = 250 \Omega ; R_2 = R_4 = 62.5 \Omega$</p>	<p style="text-align: center;">LVDS Test Circuit</p>
<p style="text-align: center;">HCSSL Test Circuit</p> <p>$R_s = 0 \text{ to } 33\Omega \text{ to minimize ringing in application.}$</p>	<p style="text-align: center;">LPHCSL Test Circuit for HCLK only</p>

Differential Crystal Oscillators with No PLL

Differential

HPRK	HDRK	HCRK	SMD	1.8 V	2.5 V	3.3 V	Min.	Max.
LVPECL Differential	LVDS Differential	HCSL Differential					10.0 MHz	250 MHz

Features

Jitter 0.1 pS (typical)

- Femtosecond integrated phase jitter (84 fs (typ.) , 12 KHz to 20 MHz)
- Superior phase noise (-139 dBc/Hz at 10 KHz and -148 dBc/Hz at 100 KHz offset)
- Package size : 2.5x2.0mm , 3.2x2.5mm , 5.0x3.2mm , 7.0x5.0mm

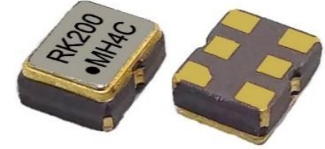

General specifications , at Ta=+25°C

Model	HPRK	HDRK		HCRK	
Output Logic	LVPECL	LVDS		HCSL	
Available Frequency Range	10 MHz ~ 250 MHz	10 MHz ~ 250 MHz	10 MHz ~ 160 MHz 180 MHz ~ 250 MHz	20 MHz ~ 50 MHz 60 MHz ~ 220 MHz	100 MHz ~ 160 MHz
Supply Voltage (V _{DD})	--	--	+1.8 V ± 5%	--	+1.8 V ± 5%
	+2.5 V ± 10%	+2.5 V ± 10%	--	+2.5 V ± 10%	--
	+3.3 V ± 10%	+3.3 V ± 10%	--	+3.3 V ± 10%	--
Current Consumption (V _{DD} = + 3.3V)	32 mA (typ.) 60 mA (max.)	10 mA (typ.) 25 mA (max.)	8 mA (typ.) 16 mA (max.)	17 mA (typ.) 35 mA (max.)	
Output Logic " High " , " 1 "	V _{DD} - 1.03 (min.) V _{DD} - 0.6 (max.)	1.4 V (typ.) 1.6 V (max.)	0.8 V (typ.) 1.0 V (max.)	550 mV (min.) 1.0 V (max.)	
Output Logic " Low " , " 0 "	V _{DD} - 1.85 (min.) V _{DD} - 1.6 (max.)	0.9 V (min.) 1.1 V (typ.)	0.3 V (min.) 0.5 V (typ.)	-150 mV (min.) 150 mV (max.)	
Rise Time / Fall Time (20%↔80% of waveform)	0.3 nsec. (typ.) 0.5 nsec. (max.)	0.2 nsec. (typ.) 0.35 nsec. (max.)	0.2 nsec. (typ.) 0.35 nsec. (max.)	0.2 nsec. (typ.) 0.35 nsec. (max.)	
Output Voltage Swing	500 mV (min.) 750 mV (typ.)	300 mV (min.) , 400 mV (typ.) , 480 mV (max.)	200 mV (min.) , 300 mV (typ.) , 400 mV (max.)	500 mV (min.)	
Output Load	50 Ω into V _{CC} - 2V or Thevenin equivalent	100 Ω between output and complimentary output		50 Ω to ground oneach output	

Start-up Time	0.75 msec. (typ.) , 2.0 msec. (max.)						
Duty Cycle	50% ± 5%						
Storage Temperature	-55°C to +150°C						
Aging at Ta = +25°C	± 3 ppm (max.) first year ; ± 2 ppm (max.) per year thereafter						
RMS Jitter (12 KHz to 20 MHz)	84 fsec (typ.) ; For 156.250 MHz , LVPECL 3.3V						
SSB Phase Noise [dBc / Hz (typ.)]	Offset	10 Hz	100 Hz	1 KHz	10 KHz	100 KHz	1 MHz
	156.250 MHz	-63	-97	-134	-139	-148	-153
Frequency Stability Codes	Frequency Stability over Operating Temperature Range	± 25 ppm	± 50 ppm	± 100 ppm	If non-standard , please enter the desired stability after the " C " ; " F " ; " J " represents . For example : " C20 " ± 20 ppm over -20°C to +70°C ; " F30 " ± 30 ppm over -40°C to +85°C ; " J40 " ± 40 ppm over -40°C to +105°C		
	Commercial (-20°C to +70°C)	A	B	C			
	Industrial (-40°C to +85°C)	D	E	F			
	Extended Industrial (-40°C to +105°C)	G	H	J			
Output Enable / Disable Function	Enable	When 70% min. of V _{DD} to Enable Output. Enable time : 2 msec (max.)					
	Disable	When 30% max. of V _{DD} to Disable Output. Disable current : 30 uA (max.)(OE ≤ 0.3V) , Disable time : 0.2 usec. (max.)					

Oscillators

HPRK [LVPECL Differential]

HDRK [LVDS Differential]

HCRK [HCSL Differential]

Part Number Format and Example

Example	[1]	[2]	[3]	-	[4]	-	[5]
	Supply Voltage	Holder Type	1 or 2		Frequency Stability		Center Frequency
(1)	25V3	HDRK576	1	-	E	-	100.000
(2)	18	HPRK326	1	-	D	-	156.250

Ex (1) : **25V3HDRK5761 - E - 100.000** [+2.5 ~ +3.3V, HDRK type, LVDS output, 7.0 x 5.0mm size, OE on pad 1, ±50 ppm from -40°C to 85°C, 100.000MHz]

Ex (2) : **18HPRK3261 - D - 156.250** [+1.8V, HPRK type, LVPECL output, 3.2 x 2.5mm size, OE on pad 1, ±25 ppm from -40°C to 85°C, 156.250MHz]

[1]	Supply Voltage , " 18 " for +1.8V ; " 25 " for +2.5V ; " 3 " for +3.3V ; " 25V3 " for +2.5 ~ +3.3V ±10%	
[2]	Holder Type	
[3]	" 1 " : OE function on pad # 1 , " 2 " : OE function on pad # 2	
[4]	-20°C ~ 70°C	" A " ± 25ppm ; " B " ± 50ppm ; " C " ± 100ppm ; If non-standard please enter the desired stability after " C " , for example " C20 " : represents ±20ppm over -20 to +70°C
	-40°C ~ 85°C	" D " ± 25ppm ; " E " ± 50ppm ; " F " ± 100ppm ; If non-standard please enter the desired stability after " F " , for example " F30 " : represents ±30ppm over -40 to +85°C
	-40°C ~ 105°C	" G " ± 25ppm ; " H " ± 50ppm ; " J " ± 100ppm ; If non-standard please enter the desired stability after " J " , for example " J40 " : represents ±40ppm over -40 to +105°C
[5]	Frequency in MHz	

Outline Dimensions (Unit : mm) , Suggested pad Layout for SMDs , Test Circuits

<h4>H_RK226</h4> <p>Pad Connections : Pad 1 : OE Pad 2 : No Connection Pad 3 : Ground Pad 4 : Output Pad 5 : Complementary Pad 6 : Supply Voltage</p>		<h4>H_RK326</h4> <p>Pad Connections : Pad 1 : OE Pad 2 : No Connection Pad 3 : Ground Pad 4 : Output Pad 5 : Complementary Pad 6 : Supply Voltage</p>	
<h4>H_RK536</h4> <p>Pad Connections : Pad 1 : OE Pad 2 : No Connection Pad 3 : Ground Pad 4 : Output Pad 5 : Complementary Pad 6 : Supply Voltage</p>		<h4>H_RK576</h4> <p>Pad Connections : Pad 1 : OE Pad 2 : No Connection Pad 3 : Ground Pad 4 : Output Pad 5 : Complementary Pad 6 : Supply Voltage</p>	
<h4>LVPECL Test Circuit</h4> <p>$V_{DD} = 3.3V ; R1 = R3 = 127 \Omega ; R2 = R4 = 82.5 \Omega$ $V_{DD} = 2.5V ; R1 = R3 = 250 \Omega ; R2 = R4 = 62.5 \Omega$</p>		<h4>LVDS Test Circuit</h4>	
<h4>HCSL Test Circuit</h4> <p>$R_s = 0 \text{ to } 33\Omega \text{ to minimize ringing in application.}$</p>			

Low Jitter Crystal Oscillators

HTQN

CMOS Waveform

HPQN

LVPECL Differential

HDQN

LVDS Differential

0.6 ps
RMS Jitter

SMD

2.5 V 3.3 V

Min.

50 MHz

Max.

1,500 MHz

Features

- The HTQN, HPQN and HDQN Series are members of Mercury's Low Jitter Crystal Oscillators
- Output frequency range : 50 MHz to 1,500 MHz
- Low RMS Jitter 0.6 ps typical (12kHz to 20MHz)
- Package size : 3.2x2.5mm , 5.0x3.2mm , 7.0x5.0mm

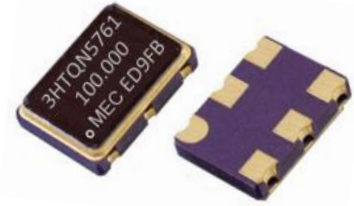

General specifications , at Ta=+25°C

Model	HTQN	HPQN	HDQN					
Output Logic	CMOS	LVPECL	LVDS					
Supply Voltage V _{DD} (code)	+ 2.5 V ± 5% (voltage code " 25 ") + 3.3 V ± 10% (voltage code " 3 ")	+ 2.5 V ± 5% (voltage code " 25 ") + 3.3 V ± 10% (voltage code " 3 ")	+ 2.5 V ± 5% (voltage code " 25 ") + 3.3 V ± 10% (voltage code " 3 ")					
Available Frequency Range	50 ~ 250 MHz	50 ~ 1,500 MHz	50 ~ 1,500 MHz					
Output Load	15 pF	50 Ω into V _{CC} - 2V or Thevenin equivalent	100 Ω					
Output Logic " High " , " 1 "	90 % V _{DD}	V _{DD} - 1.03 (min.) , V _{DD} - 0.6 (max.)	1.4 V (typ.) , 1.6 V (max.)					
Output Logic " Low " , " 0 "	10 % V _{DD}	V _{DD} - 1.85 (min.) , V _{DD} - 1.6 (max.)	1.1 V (typ.) , 0.9 V (min.)					
Current with Output Disable	16 mA (typ.)	16 mA (typ.)	16 mA (typ.)					
Current Consumption (max.) (V _{DD} = + 3.3V)	50 ~ 100 MHz : 30 mA	150 ~ 250 MHz : 50 mA	150 ~ 250 MHz : 30 mA					
	101 ~ 150 MHz : 38 mA	251 ~ 750 MHz : 55 mA	251 ~ 750 MHz : 34 mA					
	151 ~ 200 MHz : 43 mA	751 ~ 1000 MHz : 57 mA	751 ~ 1,000 MHz : 38 mA					
	201 ~ 250 MHz : 48 mA	1001 ~ 1500 MHz : 60 mA	1001 ~ 1,500 MHz : 40 mA					
Rise Time / Fall Time	1.5 nsec. (typ.) , 3.0 nsec. (max.) Tr / Tf : 10% ↔ 90% waveform	0.2 nsec. (typ.) , 0.5 nsec. (max.) Tr / Tf : 20% ↔ 80% waveform	0.2 nsec. (Typ.) , 0.5 nsec. (max.) Tr / Tf : 20% ↔ 80% waveform					
Start-up Time	10 msec. (max.)	5.0 msec. (typ.) , 10 msec. (max.)	5.0 msec. (typ.) , 10 msec. (max.)					
Aging at Ta = +25°C	± 5 ppm (max.) for first year	± 3 ppm (max.) first year ; ± 2 ppm (max.) per year thereafter	± 3 ppm (max.) first year ; ± 2 ppm (max.) per year thereafter					
Duty Cycle	50% ± 5%							
Storage Temperature	-55°C to +150°C							
RMS Jitter (12 KHz to 20 MHz)	0.6 psec (typ.)							
SSB Phase Noise [dBc / Hz (typ.)]	Offset	10 Hz	100 Hz	1 KHz	10 KHz	100 KHz	1 MHz	10 MHz
	156.250 MHz	-55	- 85	-109	-116	-118	-139	-146
	622.08 MHz	-48	- 85	-101	-102	-103	-124	-133
Frequency Stability Codes	Frequency Stability over Operating Temperature Range	± 25 ppm	± 50 ppm	± 100 ppm	If non-standard , please enter the desired stability after the " C " or " F " represents . For example : " C20 " ± 20 ppm over -20°C to +70°C ; " F30 " ± 30 ppm over -40°C to +85°C			
	Commercial (-20°C to +70°C)	A	B	C				
	Industrial (-40°C to +85°C)	D	E	F				
Output Enable / Disable Function	Enable	When 70% (min.) of V _{DD} to Enable Output. Enable time : 200 nsec. (max.)						
	Disable	When 30% (max.) of V _{DD} to Disable Output. Disable current : 16 mA (max.) , Disable time : 50 nsec. (max.)						

Crystal Oscillators

HTQN [CMOS Waveform]

HPQN [LVPECL Differential]

HDQN [LVDS Differential]

Part Number Format and Example

	[1]	[2]	[3]		[4]		[5]
	Supply Voltage	Holder Type	1 or 2	-	Frequency Stability	-	Center Frequency
Example	(1)	25	HPQN576	2	-	D	622.080
	(2)	3	HDQN326	1	-	A	100.000

Ex (1) : **25HPQN5762 - D - 622.080** [+2.5V , H_ 576 type , LVPECL output , QN series , OE on pad # 2 , ±25 ppm from -40°C to 85°C , 622.080MHz]

Ex (2) : **3HDQN3261 - A - 100.000** [+3.3V , H_ 326 type , LVDS output , QN series , OE on pad # 1 , ±25 ppm from -20°C to 70°C , 100.000MHz]

[1]	Supply voltage , " 2.5 " for +2.5V ; " 3 " for +3.3V	
[2]	Holder Type	
[3]	" 1 " : OE function on pad # 1 , " 2 " : OE function on pad # 2	
[4]	-20°C ~ 70°C	" A " ± 25ppm ; " B " ± 50ppm ; " C " ± 100ppm ; If non-standard please enter the desired stability after " C " , for example " C15 " : represents ± 15ppm over -20 to +70°C
	-40°C ~ 85°C	" D " ± 25ppm ; " E " ± 50ppm ; " F " ± 100ppm ; If non-standard please enter the desired stability after " F " , for example " F30 " : represents ± 30ppm over -40 to +85°C
[5]	Frequency in MHz	

Outline Dimensions (Unit : mm) , Suggested pad Layout for SMDs ; Test Circuit

<p style="text-align: center;">H_QN326</p>	<p style="text-align: center;">H_QN536</p>	
<p style="text-align: center;">H_QN576</p>	<p style="text-align: center;">Pad Connections :</p> <ul style="list-style-type: none"> Pad 1 : Output Enable Pad 2 : No Connection Pad 3 : Ground Pad 4 : CMOS : Output , Differential : Output Pad 5 : CMOS : No Connection , Differential : Complementary Output Pad 6 : Supply Voltage 	
<p style="text-align: center;">CMOS Test Circuit</p>	<p style="text-align: center;">LVPECL Test Circuit</p> <p style="font-size: small;"> $V_{DD} = 3.3V ; R1 = R3 = 127 \Omega ; R2 = R4 = 82.5 \Omega$ $V_{DD} = 2.5V ; R1 = R3 = 250 \Omega ; R2 = R4 = 62.5 \Omega$ </p>	<p style="text-align: center;">LVDS Test Circuit</p>

Crystal Oscillators [Quick - Turn Clock Oscillators , 10 ~ 1500 MHz]

HTQF
CMOS Waveform

HPQF
LVPECL Differential

HDQF
LVDS Differential

Q family

F series

SMD
2.5 V
3.3 V
Min.
10 MHz
Max.
1,500 MHz
Features
Quick - Turn Clock Oscillators
0.8 ps Phase Jitter (typical)

- The HTQF, HPQF and HDQF Series are members of Mercury's Q-Family Quick-Turn crystal oscillators
- Output frequency range : 10 MHz to 1,500 MHz
- Package size : 3.2 x 2.5mm , 5.0 x 3.2mm , 7.0 x 5.0mm
- Next-day samples for prototypes

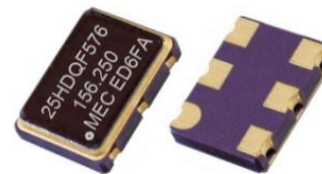
General specifications , at Ta=+25°C

Model	HTQF	HPQF	HDQF					
Output Logic	CMOS	LVPECL	LVDS					
Supply Voltage V _{DD} (code)	+ 2.5 V ± 5% (voltage code " 25 ") + 3.3 V ± 10% (voltage code " 3 ")	+ 2.5 V ± 5% (voltage code " 25 ") + 3.3 V ± 10% (voltage code " 3 ")	+ 2.5 V ± 5% (voltage code " 25 ") + 3.3 V ± 10% (voltage code " 3 ")					
Available Frequency Range	10 ~ 250 MHz	10 ~ 1,500 MHz	10 ~ 1,500 MHz					
Load	15 pF	50 Ω into V _{cc} - 2V or Thevenin equivalent	100 Ω					
Output Logic " High " , " 1 "	90 % V _{DD}	V _{DD} - 1.03 (min.) , V _{DD} - 0.6 (max.)	1.4 V (typ.) , 1.6 V (max.)					
Output Logic " Low " , " 0 "	10 % V _{DD}	V _{DD} - 1.85 (min.) , V _{DD} - 1.6 (max.)	1.1 V (typ.) , 0.9 V (min.)					
Current with Output Disable	16 mA (typ.)	16 mA (typ.)	16 mA (typ.)					
Current Consumption (Max.) (V _{DD} = + 3.3V)	10 ~ 50 MHz : 30 mA	10 ~ 250 MHz : 50 mA	10 ~ 250 MHz : 30 mA					
	51 ~ 150 MHz : 38 mA	251 ~ 750 MHz : 55 mA	251 ~ 750 MHz : 34 mA					
	151 ~ 250 MHz : 48 mA	751 ~ 1,500 MHz : 60 mA	751 ~ 1,500 MHz : 40 mA					
Rise Time / Fall Time	1.5 nsec. (typ.) , 3.0 nsec. (max.) Tr / Tf : 10% ↔ 90% waveform	0.2 nsec. (typ.) , 0.5 nsec. (max.) Tr / Tf : 20% ↔ 80% waveform	0.2 nsec. (typ.) , 0.4 nsec. (max.) Tr / Tf : 20% ↔ 80% waveform					
Duty Cycle	50% ± 5%							
Start-up Time	10 msec. (max.)							
Aging at Ta = +25°C	± 2 ppm (max.) first year ; ± 10 ppm (max.) over 10 years							
Storage Temperature	-55°C to +150°C							
RMS Jitter (12 KHz to 20 MHz)	0.8 psec (typ.)							
SSB Phase Noise [dBc / Hz (typ.)]	Offset	10 Hz	100 Hz	1 KHz	10 KHz	100 KHz	1 MHz	10 MHz
	156.250 MHz	-55	-85	-109	-116	-118	-139	-146
	622.08 MHz	-48	-85	-101	-102	-103	-124	-133

Frequency Stability Codes	Frequency Stability over Operating Temperature Range	± 25 ppm	± 50 ppm	± 100 ppm	If non-standard , please enter the desired stability after the " C " or " F " represents . For example : " C20 " ± 20 ppm over -20°C to +70°C ; " F30 " ± 30 ppm over -40°C to +85°C
	Commercial (-20°C to +70°C)	A	B	C	
	Industrial (-40°C to +85°C)	D	E	F	

Output Enable Function

OE Control on Pad 1	70% of V _{DD} (min.) to enable output. (Open connection prohibit.)
	30% of V _{DD} (max.) to disable output.
Output Enable Time / Disable Time	200 nsec. (max.) / 50 nsec. (max.)

Crystal Oscillators [Quick - Turn Clock Oscillators , 10 ~ 1500 MHz]

HTQF [CMOS Waveform]

HPQF [LVPECL Differential]

HDQF [LVDS Differential]

Part Number Format and Example

	[1]	[2]	[3]		[4]		[5]
	Supply Voltage	Holder Type	1 or 2	-	Frequency Stability	-	Center Frequency
Example	(1)	3	HTQF536	2	B	-	200.000
	(2)	3	HDQF326	1	A	-	100.000

Ex (1) : **3HTQF5362 - B - 200.000** [+3.3V , H_ 536 type , CMOS output , QF series , OE on pad # 2 , ±50 ppm from -20°C to 70°C , 200.000MHz]

Ex (2) : **3HDQF3261 - A - 100.000** [+3.3V , H_ 326 type , LVDS output , QF series , OE on pad # 1 , ±25 ppm from -20°C to 70°C , 100.000MHz]

[1]	Supply voltage , " 25 " for +2.5V ; " 3 " for +3.3V		
[2]	Holder Type		
[3]	" 1 " : OE function on pad # 1 ; " 2 " : OE function on pad # 2		
[4]	-20°C ~ 70°C	" A " ± 25ppm ; " B " ± 50ppm ; " C " ± 100ppm ; If non-standard please enter the desired stability after " C " , for example " C15 " : represents ±15ppm over -20 to +70°C	
	-40°C ~ 85°C	" D " ± 25ppm ; " E " ± 50ppm ; " F " ± 100ppm ; If non-standard please enter the desired stability after " F " , for example " F30 " : represents ± 30ppm over -40 to +85°C	
[5]	Frequency in MHz		

Outline Dimensions (Unit : mm) , Suggested pad Layout for SMDs ; Test Circuit

<p style="text-align: center;">H_QF326</p>	<p style="text-align: center;">H_QF536</p>	
<p style="text-align: center;">H_QF576</p>	<p style="text-align: center;">Pad Connections :</p> <ul style="list-style-type: none"> Pad 1 : Output Enable Pad 2 : No Connection Pad 3 : Ground Pad 4 : CMOS : Output , Differential : Output Pad 5 : CMOS : No Connection , Differential : Complementary Output Pad 6 : Supply Voltage 	
<p style="text-align: center;">CMOS Test Circuit</p>	<p style="text-align: center;">LVPECL Test Circuit</p> <p style="text-align: center;"> $V_{DD} = 3.3V ; R1 = R3 = 127 \Omega ; R2 = R4 = 82.5 \Omega$ $V_{DD} = 2.5V ; R1 = R3 = 250 \Omega ; R2 = R4 = 62.5 \Omega$ </p>	<p style="text-align: center;">LVDS Test Circuit</p>

High Frequency Ultra-low Jitter Crystal Oscillators [Quick - Turn Oscillators , 50 ~ 2,100 MHz]

H_JFN

CMOS / Differential

**Quick - Turn
Clock Oscillators**

**150 fsec
RMS Jitter**

SMD

1.8 V

2.5 V

3.3 V

Min.

50 MHz

Max.

2,100 MHz

Features

- High Frequency Range : 50 ~ 2,100 MHz
- Ultra-low RMS Jitter : 150 fsec (typ.) @ 3.3V , 156.250 MHz
- Package Size : 3.2 x 2.5mm and 5.0 x 3.2mm and 7.0 x 5.0mm
- Next-Day sample for Prototypes

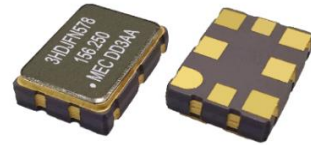

General specifications , at Ta = +25°C

Model	HTJFN	HPJFN	HDJFN	HCJFN	HQJFN
Output Logic	CMOS (*1)	LVPECL	LVDS	HCSL	CML
Supply Voltage (V _{DD})	+ 1.8 V ± 5%	--	+ 1.8 V ± 5% (*2)	+ 1.8 V ± 5%	+ 1.8 V ± 5%
	+ 2.5 V ± 10%	+ 2.5 V ± 10%	+ 2.5 V ± 10%	+ 2.5 V ± 10%	+ 2.5 V ± 10%
	+ 3.3 V ± 10%	+ 3.3 V ± 10%	+ 3.3 V ± 10%	+ 3.3 V ± 10%	+ 3.3 V ± 10%
Available Frequency Range	50 ~ 250 MHz	50 ~ 2,100 MHz	50 ~ 2,100 MHz	50 ~ 700 MHz	50 ~ 2,100 MHz
Output Load	15 pF (max.)	50 Ω into V _{DD} - 2V or Thevenin equivalent	100 Ω	50 Ω to GND	50 Ω to V _{DD}
Output Logic " High " , " 1 "	V _{DD} - 0.4 V (min.)	V _{DD} - 1.165 V (min.) V _{DD} - 0.8 V (max.)	V _{DD} : 1.4 V (typ.) V _{DD} : 1.6 V (max.)	V _{DD} : 0.66 V (min.) V _{DD} : 1.15 V (max.)	V _{DD} - 0.085 V (min.) V _{DD} = (max.)
Output Logic " Low " , " 0 "	V _{DD} x 0.1 V (max.) 0.3V (max.) for 1.8V only	V _{DD} - 2.0 V (min.) V _{DD} - 1.55 V (max.)	V _{DD} : 1.1 V (typ.) V _{DD} : 0.9 V (min.)	V _{DD} : - 0.15 V (min.) V _{DD} : 0.15 V (max.)	V _{DD} - 0.6 V (min.) V _{DD} - 0.32 V (max.)
Output Voltage Swing	---	595 mV (min.) 930 mV (max.)	250 mV (min.) 450 mV (max.)	450 mV (min.) 700 mV (typ.)	200 mV (min.) 600 mV (max.)
Current Consumption (V _{DD} = + 3.3 V)	75 mA (typ.) 90 mA (max.)	100 mA (typ.) 120 mA (max.)	75 mA (typ.) 90 mA (max.)	94 mA (typ.) 115 mA (max.)	70 mA (typ.) 85 mA (max.)
Disable Current	62 mA (typ.)	99 mA (typ.)	74 mA (typ.)	93 mA (typ.)	69 mA (typ.)
Rise Time / Fall Time (20% to 80% Waveform)	5.0 nsec. (max.) (10% to 90%)	0.4 nsec. (max.)	0.4 nsec. (max.)	0.4 nsec. (max.)	0.4 nsec. (max.)

Frequency Stability Codes	Frequency Stability Over Operating Temperature Range	± 25 ppm	± 50 ppm	± 100 ppm
	Commercial (-20°C to +70°C)	A	B	C
	Industrial (-40°C to +85°C)	D	E	F
	Extended Industrial (-40°C to +105°C)	---	H	J
Duty Cycle	50% ± 5%			
Start-up Time	5 msec (typ.) ; 10 msec (max.)			
RMS Jitter (typ.) (12 KHz to 20 MHz)	156.250 MHz : 159 fsec ; 491.520 MHz : 155 fsec ; 644.530 MHz : 151 fsec ; 2,000 MHz : 163 fsec			
Storage Temperature	-55°C to +150°C			
Aging at Ta = +25°C	± 3 ppm (max.) for first year ; ± 2 ppm (max.) per year thereafter			
Enable / Disable Function on Pad1	80% of V _{DD} (min.) to enable output.			
	20% of V _{DD} (max.) to disable output.			
Enable / Disable Time	2.5 msec (max.) / 10 usec (max.)			

Note *1 : For CMOS output , only 7.0x5.0mm and 5.0x3.2mm packages are available.
 Note *2 : This needs AC coupling (100-nF series capacitor). Please check the test circuit.

High Frequency Ultra-low Jitter Crystal Oscillators [Quick - Turn Oscillators , 50 ~ 2,100 MHz]

H_JFN

CMOS / Differential

**Quick - Turn
Clock Oscillators**

**150 fsec
RMS Jitter**

SMD

1.8 V

2.5 V

3.3 V

Min.

50 MHz

Max.

2,100 MHz

Part Number Format and Example

	[1]	[2]	[3]	[4]	[5]	[6]	[7]	[8]
	Supply Voltage	OSC Type	Output Waveform	Series	Package Size	OE Function	Frequency Stability	Center Frequency
Example (1)	3	H	P	JFN	328	1	D	250.000
Example (2)	3	H	D	JFN	578	1	E	644.530

EX (1): **3HPJFN3281 - D - 250.000** [+3.3V, HPJFN type, PECL output, 3.2x2.5mm 8pad, OE on pad1, ±25ppm from -40 to +85°C, 250.000 MHz]

EX (2): **3HDJFN5781 - E - 644.530** [+3.3V, HDJFN type, LVDS output, 7.0x5.0mm 8pad, OE on pad1, ±50ppm from -40 to +85°C, 644.530 MHz]

[1]	Supply Voltage, " 18 " for +1.8V ; " 25 " for +2.5V ; " 3 " for +3.3V							
[2]	OSC Type, " H " : XO							
[3]	Output Waveform, " T " : CMOS ; " P " : LVPECL ; " D " : LVDS ; " C " : HCSL ; " Q " : CML							
[4]	JFN Series							
[5]	Package Size, " 328 " : 3.2 x 2.5 mm 8pad ; " 538 " : 5.0 x 3.2 mm 8pad ; " 578 " : 7.0 x 5.0 mm 8pad							
[6]	" 1 " : OE function on pad # 1							
[7]	-20°C ~ 70 °C	" A " ± 25ppm ; " B " ± 50ppm ; " C " ± 100ppm						
	-40°C ~ 85 °C	" D " ± 25ppm ; " E " ± 50ppm ; " F " ± 100ppm						
	-40°C ~ 105 °C	" H " ± 50ppm ; " J " ± 100ppm						
[8]	Frequency in MHz							

Outline Dimensions (Unit : mm) , Suggested pad Layout for SMDs

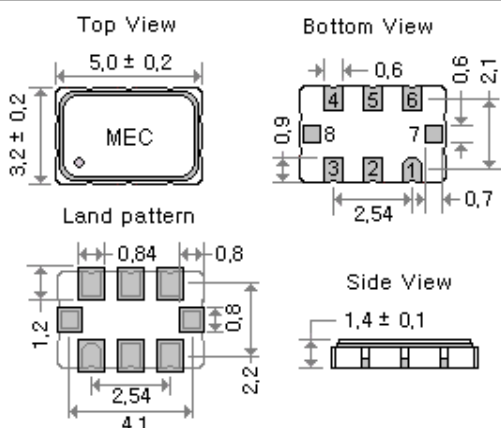
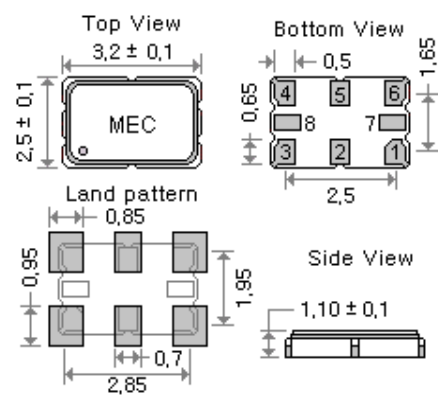
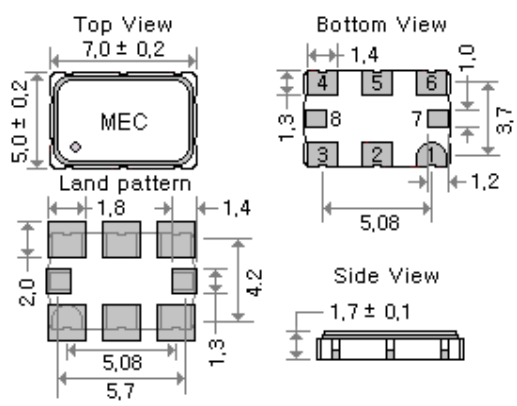
H_JFN538	H_JFN328
	
H_JFN578	Pad Connections :
	<p>Pad 1 : Output Enable Pad 2 : No Connection Pad 3 : Ground Pad 4 : CMOS : Output , Differential : Output Pad 5 : CMOS : No Connection , Differential : Complementary Output Pad 6 : Supply Voltage Pad 7 : Do Not Connect Pad 8 : Do Not Connect</p>

High Frequency Ultra-low Jitter Crystal Oscillators [Quick - Turn Oscillators , 50 ~ 2,100 MHz]

H_JFN

CMOS / Differential

**Quick - Turn
Clock Oscillators**

**150 fsec
RMS Jitter**

SMD

1.8 V

2.5 V

3.3 V

Min.

50 MHz

Max.

2,100 MHz

Test Circuits

CMOS	HCSL	LVDS Test Circuits for 2.5V and 3.3V
LVPECL	CML	LVDS Test Circuits for 1.8V only (*2)
<p> $V_{DD} = 3.3V$; $R1 = R3 = 127 \Omega$; $R2 = R4 = 82.5 \Omega$ $V_{DD} = 2.5V$; $R1 = R3 = 250 \Omega$; $R2 = R4 = 62.5 \Omega$ </p>		

Oscillators

EMI Reduction Spread Spectrum Clock Oscillators

A Drop-in Replacement Solution For Your EMI / EMC Compliance Problem

The principle sources of the EMI problems come from the system clocks. Therefore, rather than patching the problem with ferrite beads, EMI filters, ground plane and metal shielding, the most efficient and economical way to reduce the peak radiation energy is to use a spread spectrum clock oscillator .

Compared with conventional clock oscillator , Mercury's HM series spread spectrum (dithered) clock oscillator can reduce EMI as much as 12dB. The beauty is that it is a drop-in replacement for your existing 7 x 5mm , 5 x 3.2mm clock oscillator. No need to re-spin the board.

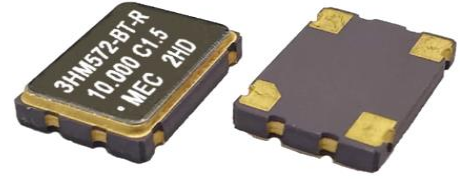

Applications :

- Printers; Multiple function printers (MPCs)
- Digital copiers; PDAs
- Networking; LAN / WAN; Routers
- Storage systems (CD-ROM, VCD, DVD and HDD)
- Scanner; Modems; projectors
- Hand-held ID readers
- Embedded systems; Electrical musical instrument
- Automotive; GPS car navigation systems
- LCD PC monitors / LCD TVs
- ADSL; PCMCIA
- Still Digital cameras (SDCs)

Modulation Types : [Output amplitude (dB) vs frequency span (MHz)]

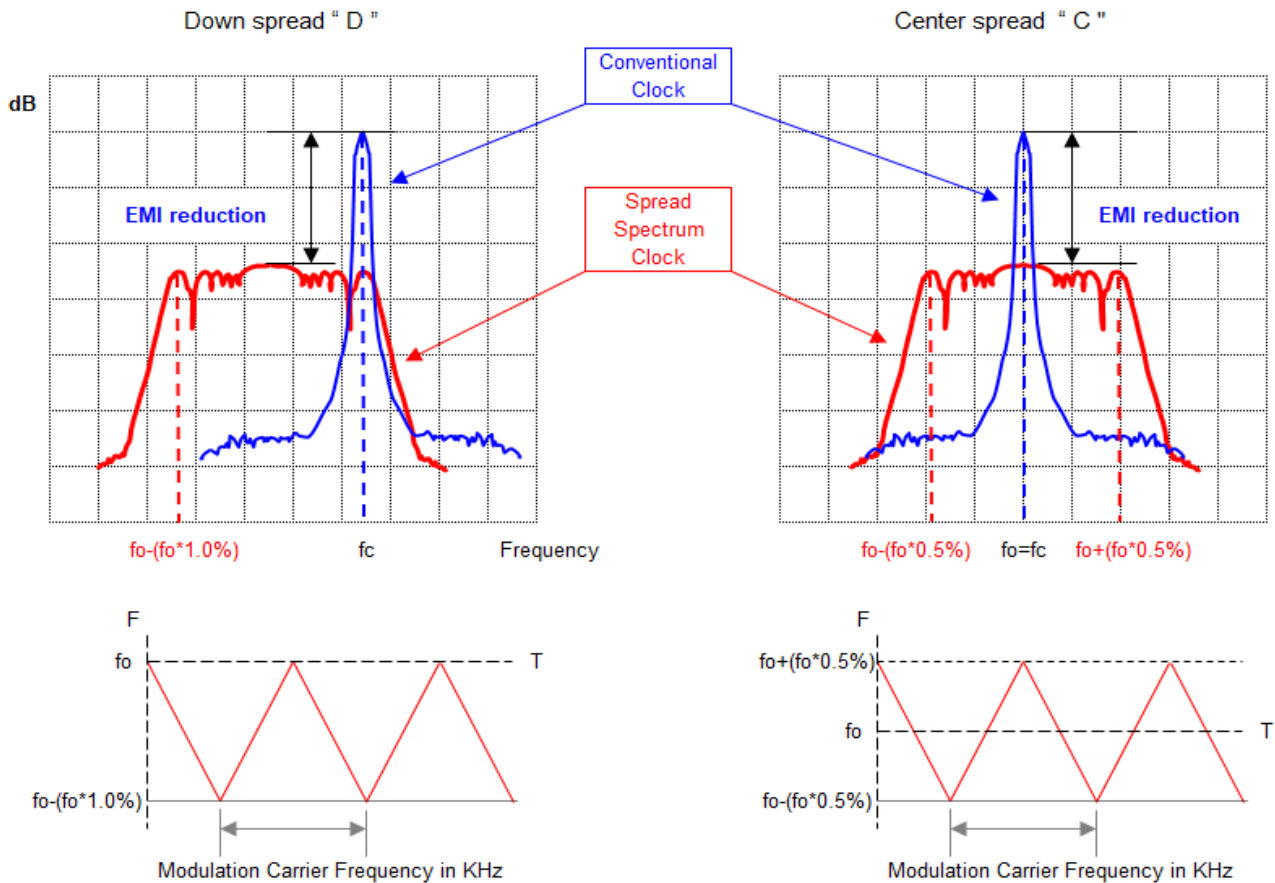

Spread Spectrum Clock (SSC) :

Unlike a conventional clock, the mode energy of a spread spectrum clock is spread over a wider bandwidth, resulting from the **frequency modulation** technique.

The modulation carrier frequency is in the KHz range which makes the modulation process transparent to the oscillator frequency.

The controlled modulation process can be all on one side of the nominal frequency (**down spread**) or 50% higher and 50% lower (**center spread**) of the nominal frequency. Down spread is preferred if over-clocking is a problem to the system.

EMI Reduction Spread Spectrum Clock Oscillators [Programmable Quick Turn]

HM _ B

**Quick - Turn
Clock Oscillators**

B group

SMD

CMOS

2.5V

3.3V

Min.

3.0 MHz

Max.

200 MHz

- Reduces electromagnetic Interference (EMI) by approx. 12 dB to 18 dB .
- Drop-In Replacement for Conventional Oscillators
- No Need to Re-Spin the Board or Solder Pad Layout
- Operates with a +2.5V or 3.3V Supply Voltage
- 5.0 x 3.2 , 7.0 x 5.0 mm package size

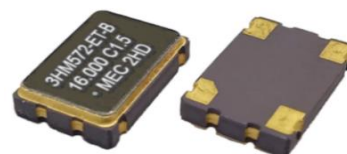

General specifications of all available packages , at Ta=+25°C , CL=15p

Group	B group	
Available Packages	HM53 (5.0 * 3.2 * 1.2 mm)	HM572 (7.0 * 5.0 * 1.4 mm)
Output Waveform	CMOS (square wave)	
Supply Voltage (V _{DD})	+ 2.5 V ± 10%	+ 3.3 V ± 10%
Frequency Range	3.0 MHz ~ 166 MHz	3.0 MHz ~ 200 MHz
Output Logic High " 1 "	2.25 V (min.)	2.97 V (min.)
Output Logic Low " 0 "	0.25 V (max.)	0.33 V (max.)

Spread Type	Spread Percentage EMI Reduction Rate			
Center Spread (" C ")	± 0.125 % (C0.125) to ± 2.0 % (C2.0) in ± 0.125 % steps			
Down Spread (" D ")	- 0.25 % (D0.25) to - 4.0 % (D4.0) in 0.25 % steps			
Frequency Stability Codes (exclude modulation)	Frequency Stability over Operating Temperature Range	± 25 ppm	± 50 ppm	± 100 ppm
	Commercial (-20°C to +70°C)	A	B	C
	Industrial (-40°C to +85°C)	D	E	F
Modulation Carrier Freq. (Dither rate)	30 KHz (min.) ; 40.0 KHz (max.) Frequency dependent. Call for details.			
Current Consumption	3 MHz ~ 100 MHz : 20 mA (max.)	101 MHz ~ 200 MHz : 30 mA (max.)		
Rise Time / Fall Time	5.0 nsec (max.) , 10% ↔ 90% waveform			
Output Load	15 pF			
Start-up Time	3.0 msec. (typ.) ; 5 msec. (max.)			
Duty Cycle	50% ± 10%			
Aging at Ta = +25°C	± 5 ppm per year (max.)			
Storage Temperature	-55°C to + 125°C			
Output Enable / Disable Function	Enable	70% (min.) of V _{DD} to Enable Output.		
	Disable	30% (max.) of V _{DD} to Disable Output.		
	Output enable / disable time : 100 nsec. (max.)			

EMI Reduction Spread Spectrum Clock Oscillators

HM_C

EMI Reduction Spread Spectrum Clock Oscillators

C group

SMD

CMOS

1.8V

2.5V

3.3V

Min.

16 MHz

Max.

40 MHz

- Reduce electromagnetic interference (EMI) by approx. 3 dB to 12 dB
- Operates with +1.8V to +3.3V supply voltage
- 2.5 x 2.0 , 3.2 x 2.5 , 5.0 x 3.2 , 7.0 x 5.0 mm package size

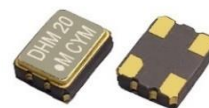

General specifications of all available packages , at Ta=+25°C , CL=15pF

Group	C Group			
Type	HM22	HM32	HM53	HM572
Dimensions	2.5 * 2.0 * 0.9 mm	3.2 * 2.5 * 1.0 mm	5.0 * 3.2 * 1.2 mm	7.0 * 5.0 * 1.4 mm
Frequency Range	16 ~ 40 MHz			
Supply Voltage (V _{DD})	1.8 V ± 10%	2.5 V ± 10%	3.3 V ± 10%	
Output Logic " High " , " 1 "	1.62 V (min.)	2.25 V (min.)	2.97 V (min.)	
Output Logic " Low " , " 0 "	0.18 V (max.)	0.25 V (max.)	0.33 V (max.)	
Rise Time / Fall Time [10% V _{DD} ↔ 90% V _{DD}]	10 nsec. (max.)	7 nsec. (max.)	7 nsec. (max.)	
Current Consumption	4 mA (max.)	5 mA (max.)	6 mA (max.)	
Spread Type	Total%	Down Spread	Center Spread	
Spread Percentage	2.0%	-2.0% (D2.0)	± 1.0% (C1.0)	
	1.5%	-1.5% (D1.5)	± 0.75% (C0.75)	
	1.0%	-1.0% (D1.0)	± 0.5% (C0.5)	
EMI Reduction	3 dB to 12 dB (typ.) for the main mode			
Modulation Carrier Freq. (Dither rate)	20.9 KHz (min.) ; 52.4 KHz (max.) Frequency dependent . Call for details			
Duty Cycle	50% ± 10%			
Output Waveform	CMOS			
Output Load	15pF			
Start-up Time	1.0 msec. (typ.) ; 5 msec. (max.)			
Storage Temperature	- 55°C to + 125°C			
Aging at Ta = +25°C	± 5 ppm per year (max.)			
Output Enable Function	Enable	When 70% (min.) of V _{DD} to Enable Output. (Open connection prohibit.)		
	Disable	When 30% (max.) of V _{DD} to Disable Output.		
	Output Enable Time : 5.0 msec. (max.) / Output Disable Time: 100 nsec. (max.)			
Frequency Stability Code (exclude modulation)	Freq. Stability over Operating Temperature Range: ± 50 ppm from -40°C to +85°C (Code is " E ")			

EMI Reduction Spread Spectrum Clock Oscillators

Part Number Format and Example

[1]	[2]	-	[3]	[4]	-	[5]	[6]	-	[7]
Supply Voltage	Holder Type		Frequency Stability	OE Function		Center Frequency	Group Type		Spread type Percentage

Examples	(1)	25	HM53	-	F	T	-	75.000	B	-	C2.0
	(2)	18	HM32	-	E	T	-	25.000	C	-	D1.0

Ex (1) : 25HM53 - FT - 75.000B - C2.0 [+2.5V, HM-series, HM53 type, ±100ppm from -40°C to +85°C, OE Function, 75.000MHz, B Group, 2.0% center spread]

Ex (2) : 18HM32 - ET - 25.000C - D1.0 [+1.8V, HM-series, HM32 type, ±50ppm from -40°C to +85°C, OE Function, 25.000MHz, C Group, 1.0% down spread]

[1]	Supply voltage code : " 18 " for +1.8V , " 25 " for +2.5V , " 3 " for +3.3V
[2]	Holder Type (HM53 , HM32)
[3]	-20°C ~ 70 °C " A " ± 25ppm ; " B " ± 50ppm ; " C " ± 100ppm
	-40°C ~ 85 °C " D " ± 25ppm ; " E " ± 50ppm ; " F " ± 100ppm
[4]	" T " for OE Function
[5]	Frequency in MHz
[6]	Group " B " , " C "
[7]	Spread type & percentage ; " C " for center spread , " D " for down spread

Outline Dimensions (Unit : mm) , Suggested pad Layout for SMDs

[HM22]	For group :	C	[HM32]	For group :	C
[HM53]	For group :	B C	[HM572]	For group :	B C

Frequency Switchable Crystal Oscillators [10 ~ 1,500 MHz]

HC_QF

CMOS / Differential

Q family

F series

Frequency

Switchable

Quick - Turn
Clock Oscillators

1.5 psec
RMS Jitter

SMD

2.5 V

3.3 V

Min.

10
MHz

Max.

1,500
MHz

Features

- The HCTQF, HCPQF and HCDQF Series are members of Mercury's Q-Family Quick-Turn crystal oscillators
- Output frequency range : 10 MHz to 1,500 MHz
- Package size : 3.2 x 2.5mm , 5.0 x 3.2mm , 7.0 x 5.0mm
- Next-day samples for prototypes

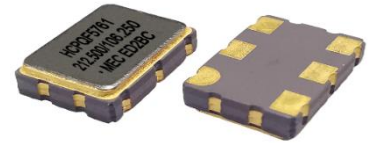

General specifications , at Ta = + 25°C

Model	HCTQF	HCPQF	HCDQF		
Output Logic	CMOS	LVPECL	LVDS		
Supply Voltage V _{DD} (code)	+ 2.5 V ± 5% (voltage code " 25 ") + 3.3 V ± 5% (voltage code " 3 ")	+ 2.5 V ± 5% (voltage code " 25 ") + 3.3 V ± 5% (voltage code " 3 ")	+ 2.5 V ± 5% (voltage code " 25 ") + 3.3 V ± 5% (voltage code " 3 ")		
Available Frequency Range	10 ~ 250 MHz	10 ~ 1,500 MHz	10 ~ 1,500 MHz		
Output Load	15 pF	50 Ω into V _{CC} - 2V or Thevenin equivalent	100 Ω		
Output Logic " High " , " 1 "	90 % V _{DD}	V _{DD} - 1.03 (min.) , V _{DD} - 0.6 (max.)	1.4 V (typ.) , 1.6 V (max.)		
Output Logic " Low " , " 0 "	10 % V _{DD}	V _{DD} - 1.85 (min.) , V _{DD} - 1.6 (max.)	1.1 V (typ.) , 0.9 V (min.)		
Current Consumption (V _{DD} = + 2.5 V)	10 ~ 150 MHz : 30 mA (max.) 151 ~ 250 MHz : 40 mA (max.)	10 ~ 750 MHz : 50 mA (max.) 751 ~ 1,500 MHz : 55 mA (max.)	10 ~ 750 MHz : 32 mA (max.) 751 ~ 1,500 MHz : 35 mA (max.)		
Current with Output Disable	18 mA (typ.)	18 mA (typ.)	18 mA (typ.)		
Current Consumption (V _{DD} = + 3.3 V)	10 ~ 150 MHz : 38 mA (max.) 151 ~ 250 MHz : 48 mA (max.)	10 ~ 750 MHz : 55 mA (max.) 751 ~ 1,500 MHz : 60 mA (max.)	10 ~ 750 MHz : 34 mA (max.) 751 ~ 1,500 MHz : 40 mA (max.)		
Rise Time / Fall Time	10.0 nsec. (max.) Tr / Tf : 10% ↔ 90% waveform	0.5 nsec. (max.) Tr / Tf : 20% ↔ 80% waveform	0.4 nsec. (max.) Tr / Tf : 20% ↔ 80% waveform		
RMS Jitter [12 kHz ~ 20 MHz]	1.5 psec. (typ.)				
Frequency Stability Codes	Frequency Stability over Operating Temperature Range	± 25 ppm	± 50 ppm	± 100 ppm	If non-standard , please enter the desired stability after the " C " or " F " represents . For example : " C20 " ± 20 ppm over -20°C to +70°C ; " F30 " ± 30 ppm over -40°C to +85°C
	Commercial (-20°C to +70°C)	A	B	C	
	Industrial (-40°C to +85°C)	D	E	F	
Duty Cycle	50% ± 5%				
Start-up Time	10 msec. (max.)				
Aging at Ta = +25°C	± 5 ppm (max.) for first year				
Storage Temperature	-55°C to +150°C				
Output Enable Function on Pad 1					
Output Enable / Disable Function	70% of V _{DD} (min.) to enable output. (Open connection prohibit.) 30% of V _{DD} (max.) to disable output				
Output Enable Time / Disable Time	200 nsec. (max.) / 50 nsec. (max.)				
Frequency Selection Function on Pad 2					
Frequency Selection (FSEL)	When FSEL = 0 (0 V or GND) , Output frequency is Freq.1 (f 1) When FSEL = 1 (V _{DD}) , Output frequency is Freq.2 (f 2)				Default FSEL pin has internal pull-up resistor
FSEL on Pad 2	70% of V _{DD} (min.) For FSEL = 1 , Output frequency is Freq.2 (f 2) 30% of V _{DD} (max.) For FSEL = 0 , Output frequency is Freq.1 (f 1) Frequency switching time : 60 us (typ.)				

Frequency Switchable Crystal Oscillators [10 ~ 1,500 MHz]

HC_QF

CMOS / Differential

Q family

F series

Frequency
Switchable

Quick - Turn
Clock Oscillators

1.5 psec
RMS Jitter

SMD

2.5 V

3.3 V

Min.
10
MHz

Max.
1,500
MHz

Part Number Format and Example

Example : 3HCTQF576 - E - 30.000 / 120.000

3	HCTQF	576	-	E	-	30.000	/	120.000
Supply Voltage "3" for 3.3V "25" for 2.5V	HCTQF : CMOS HCPQF : LVPECL HCDQF : LVDS	Package Size "576": 7 x 5 mm "536": 5 x 3.2 mm "326": 3 x 2.5 mm	-	Frequency Stability Code "E": ±50 ppm over -40 to +85°C. Other frequency stabilities are available.	-	Custom Frequency 1 FSEL = 0 (MHz)	/	Custom Frequency 2 FSEL = 1 (MHz)

Outline Dimensions (Unit : mm) , Suggested pad Layout for SMDs

HC_QF576	HC_QF536
HC_QF326	Pad Connections
	<p>Pad 1 : OE</p> <p>Pad 2 : Frequency Selection [FSEL = 0 (f 1) , FSEL = 1 (f 2)]</p> <p>Pad 3 : Ground</p> <p>Pad 4 : [CMOS : Output , LVPECL or LVDS : Differential]</p> <p>Pad 5 : [CMOS : NC , LVPECL or LVDS : Complementary] Output</p> <p>Pad 6 : Supply Voltage</p>

Test Circuits

CMOS	LVPECL	LVDS
	<p>$V_{DD} = 3.3V; R1 = R3 = 127 \Omega; R2 = R4 = 82.5 \Omega$ $V_{DD} = 2.5V; R1 = R3 = 250 \Omega; R2 = R4 = 62.5 \Omega$</p>	

4 Frequencies Switchable Crystal Oscillators [15 ~ 2,100 MHz]

HC_JFN

CMOS / Differential

4 Frequencies Switchable

Quick - Turn Clock Oscillators

SMD

1.8 V

2.5 V

3.3 V

Min.

15 MHz

Max.

2,100 MHz

Features

150 fs Phase Jitter (typ.)

Mercury's 4 Frequencies switchable crystal oscillators that can be delivered in days
An integrated phase jitter performance of 150 fs RMS.
Supports all popular formats: CMOS, LVPECL, LVDS, HCSL and CML
Gaining its precision frequency control market position by providing engineers with
next-day samples for prototypes.

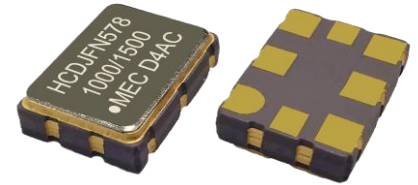

General specifications , at Ta = + 25°C

Model	HCTJFN	HCPJFN	HCDJFN	HCCJFN	HCQJFN
Output Logic	CMOS	LVPECL	LVDS	HCSL	CML
Supply Voltage V _{DD} (code)	+ 1.8 V ± 5%	--	+ 1.8 V ± 5% (*)	+ 1.8 V ± 5%	+ 1.8 V ± 5%
	+ 2.5 V ± 10%	+ 2.5 V ± 10%	+ 2.5 V ± 10%	+ 2.5 V ± 10%	+ 2.5 V ± 10%
	+ 3.3 V ± 10%	+ 3.3 V ± 10%	+ 3.3 V ± 10%	+ 3.3 V ± 10%	+ 3.3 V ± 10%
Available Frequency Range	15 ~ 250 MHz	15 ~ 2,100 MHz	15 ~ 2,100 MHz	15 ~ 700 MHz	15 ~ 2,100 MHz
Output Load	15 pF (max.)	50 Ω into V _{DD} - 2V or Thevenin equivalent	100 Ω between output and complimentary output	50 Ω to GND	50 Ω to V _{DD}
Output Logic " High " , " 1 "	V _{DD} - 0.4 V (min.)	V _{DD} - 1.03 V (min.) V _{DD} - 0.6 V (max.)	1.4 V (typ.) 1.6 V (max.)	V _{DD} : 0.66V (min.) V _{DD} : 1.15V (max.)	V _{DD} - 0.085V (min.) V _{DD} = (max.)
Output Logic " Low " , " 0 "	V _{DD} × 0.1 V (max.) 0.3V (max.) for 1.8V only	V _{DD} - 1.85 V (min.) V _{DD} - 1.6 V (max.)	1.1 V (typ.) 0.9 V (min.)	V _{DD} : - 0.15V (min.) V _{DD} : 0.15V (max.)	V _{DD} - 0.6V (min.) V _{DD} - 0.32V (max.)
Output Voltage Swing	---	595 mV (min.) 930 mV (max.)	250 mV (min.) 450 mV (max.)	450 mV (min.) 700 mV (typ.)	200 mV (min.) 600 mV (max.)
Current Consumption (V _{DD} = + 3.3 V)	75 mA (typ.) 90 mA (max.)	100 mA (typ.) 120 mA (max.)	75 mA (typ.) 90 mA (max.)	80 mA (typ.) 100 mA (max.)	70 mA (typ.) 85 mA (max.)
Current with Output Disabie	62 mA (typ.)	99 mA (typ.)	74 mA (typ.)	79 mA (typ.)	69 mA (typ.)
Rise Time / Fall Time	5.0 nsec (max.) (10% to 90% Waveform)	0.4 nsec (max.) (20% to 80% Waveform)	0.4 nsec (max.) (20% to 80% Waveform)	0.4 nsec (max.) (20% to 80% Waveform)	0.4 nsec (max.) (20% to 80% Waveform)
Frequency Stability Codes	Frequency Stability over Operating Temperature Range		± 25 ppm	± 50 ppm	± 100 ppm
	Commercial (-20°C to +70°C)		A	B	C
	Industrial (-40°C to +85°C)		D	E	F
	Extended Industrial (-40°C to +105°C)		---	H	J
Duty Cycle	50% ± 5%				
Start-up Time	5 msec (typ.) ; 10 msec. (max.)				
RMS Jitter [12 kHz ~ 20 MHz]	156.250 MHz : 148 fsec (typ.) ; 312.500 MHz : 147 fsec (typ.) ; 644.530 MHz : 141 fsec (typ.) ; 2,000 MHz : 155 fsec (typ.)				
Aging at Ta = +25°C	± 3 ppm (max.) for first year at 25°C				
Storage Temperature	-55°C to +150°C				
Frequency Selection Function					
FS0 Control on Pad 1	70% V _{DD} min. to logic Level " 1 "				
	30% V _{DD} max. to logic Level " 0 "				
FS1 Control on Pad 2	70% V _{DD} min. to logic Level " 1 "				
	30% V _{DD} max. to logic Level " 0 "				
Frequency Select Timing ; t _{FS}	10.0 msec. (max.)				
Frequency Configurations	The frequency output 1 ~ 4 setting is done based on the logic levels in the Table 1.				

Note (*) : This needs AC coupling (100-nF series capacitor). Please check the test circuit.

4 Frequencies Switchable Crystal Oscillators [15 ~ 2,100 MHz]

HC_JFN

**4 Frequencies
Switchable**

**Quick - Turn
Clock Oscillators**

SMD

1.8 V

2.5 V

3.3 V

**Min.
15
MHz**

**Max.
2,100
MHz**

Part Number Format and Example

150 fs Phase Jitter (typ.)

Example : 3HCTJFN578 - E - 156 / 250 / 622 / 1024

3	HCTJFN	578	-	E	-	156	/	250	/	622	/	1024
Supply Voltage " 3 " for 3.3V " 25 " for 2.5V " 18 " for 1.8V	HCTJFN : CMOS HCPJFN : LVPECL HCDJFN : LVDS HCCJFN : HCSL HCQJFN : CML	Package Size " 578 " (7.0 * 5.0 mm) 8pad		Freq. Stability Code E : ±50 ppm over -40 to +85°C Other temperature stabilities are available.		156.250 Freq. 1 (MHz)		250.000 Freq. 2 (MHz)		622.080 Freq. 3 (MHz)		1024.00 Freq. 4 (MHz)

Outline Dimensions (Unit : mm) , Suggested pad Layout for SMDs , Test Circuits

HC_JFN578

Pad Connection :
 Pad 1 : FS0 Control
 Pad 2 : FS1 Control
 Pad 3 : Ground
 Pad 4 : CMOS : Output
 Differential : Output
 Pad 5 : CMOS : No Used For CMOS
 Differential : Complementary Output
 Pad 6 : Supply Voltage
 Pad 7 : Do Not Connect
 Pad 8 : Do Not Connect

Frequency selection configurations

FS1	FS0	Freq. output
0	0	Freq. 1
0	1	Freq. 2
1	0	Freq. 3
1	1	Freq. 4

Table 1

CMOS Test Circuits	CML Test Circuits	LVPECL Test Circuits
		<p style="font-size: small; text-align: center;">V_{DD} = 3.3 V : R1 = R3 = 127 Ω ; R2 = R4 = 82.5 Ω V_{DD} = 2.5 V : R1 = R3 = 250 Ω ; R2 = R4 = 62.5 Ω</p>
LVDS Test Circuits for 2.5V and 3.3V	LVDS Test Circuits for 1.8V only(*)	HCSL Test Circuits

Frequency Select Timing

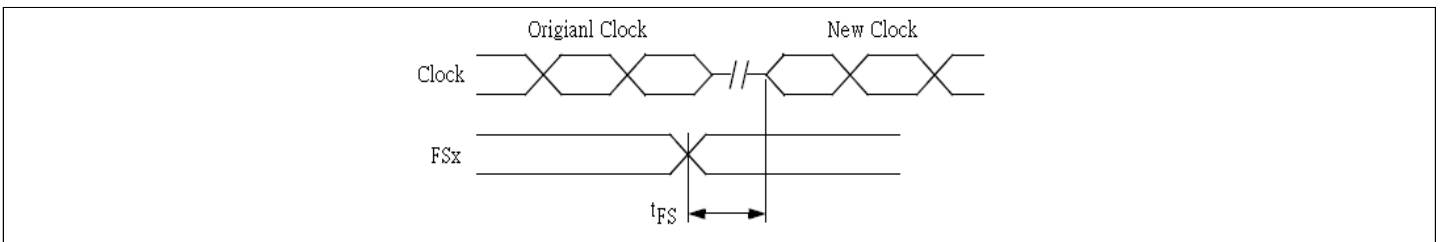

Oscillators

True Sine Wave Clock Oscillators [HS series]

HS _ _

True Sine Wave

Thru-Hole

3.3V

5.0V

Min.

10 MHz

Max.

160 MHz

Features

- High purity and low total harmonic distortion. Ideal for audio modulation applications.
- For VCXOs with a Sine Wave output, please refer to "GS" series



General specifications of all available packages , at Ta=+25°C

Model	" HS " series				
Package Dimensions , unit : mm	Thru - Hole HS14 (20.2 * 12.8 * 6.8)			Gull - Wing HS24 (20.2 * 12.8 * 7.8)	
Output Waveform	True Sine Wave				
Output Load	50Ω. (Internally AC coupled)				
Supply Voltage (V _{DD})	+3.3V ± 10%			+5.0V ± 10%	
Frequency Range	10.000 ~ 160.000 MHz			10.000 ~ 156.250 MHz	
Output Level	Standard: +3.0 dBm (min.) Tolerance: ± 1 dBm Maximum Power: +7 dBm (User to specify)			Standard: +5.0 dBm (min.) Tolerance: ± 1 dBm Maximum Power: +13 dBm (User to specify)	
Current Consumption	10 MHz : 9 mA (typ.)			10 MHz : 18 mA (typ.)	
	100 MHz : 18 mA (typ.)			100 MHz : 34 mA (typ.)	
	150 MHz : 19 mA (typ.)			150 MHz : 36 mA (typ.)	
Harmonics	< - 30dBc (frequency dependent)			< - 25dBc (frequency dependent)	
Start-up Time	5.0 msec. (max.)				
Storage Temperature	-50°C to +125°C				
Aging at Ta=+25°C	± 5 ppm per year (max.)				
Pin 1 option	OE Function ; No OE Function option				
Output Enable / Disable Function (OE Function)	70% of V _{DD} (min.) to enable output.				
	30% of V _{DD} (max.) to disable output.				
Frequency Stability Codes	Frequency Stability over Operating Temperature Range	± 25 ppm	± 50 ppm	± 100 ppm	If non-standard please enter the desired stability after the " C " or " F " represents . For example : " C20 " : ± 20 ppm over -20°C to +70°C " F30 " : ± 30 ppm over -40°C to +85°C
	Commercial -20°C to +70°C	A	B	C	
	Industrial -40°C to +85°C	D	E	F	

Outline Dimensions (Unit : mm) , Suggested pad Layout for SMDs

[HS14]	[HS24]
<div style="display: flex; justify-content: space-around;"> <div style="text-align: center;"> <p>Top View</p> </div> <div style="text-align: center;"> <p>Side View</p> </div> </div> <div style="margin-top: 10px;"> <p>Bottom View</p> <p>4-Ø1.8 glass stand-off</p> <p>Pad Connections : Pad 1 : (1) No Connection (2) OE Function Pad 7 : Ground Pad 8 : Output Pad 14 : Supply Voltage</p> </div>	<div style="display: flex; justify-content: space-around;"> <div style="text-align: center;"> <p>Top View</p> </div> <div style="text-align: center;"> <p>Side View</p> </div> </div> <div style="margin-top: 10px;"> <p>Bottom View</p> <p>4-Ø1.8 glass stand-off</p> <p>Pad Connections : Pad 1 : (1) No Connection (2) OE Function Pad 7 : Ground Pad 8 : Output Pad 14 : Supply Voltage</p> </div>

True Sine Wave Clock Oscillators [HS series]

Part Number Format and Example

[1]	[2]		[3]	[4]		[5]		[6]
Supply Voltage	Holder Type	-	Frequency Stability	Pin 1 option	-	Center Frequency	-	Output Power [HS series only]

Example	3	HS14	-	A	-	100.000	-	5
	5	HS24	-	D	T	24.000	-	10

Ex(1) : 3HS14 - A - 100.000 - 5 [+3.3V , True Sine wave , ±25ppm from -20°C to 70°C , No OE Function , 100.000MHz , Output power is 5dBm ±1dB]

Ex(2) : 5HS24 - DT - 24.000 - 10 [+5.0V , True Sine wave , ±25ppm from -40°C to 85°C , OE Function , 24.000MHz , Output power is 10dBm ±1dB]

[1]	Supply voltage , " 3 " for +3.3V ; " 5 " for +5.0V	
[2]	Holder Type	
[3]	-20°C ~ 70°C	" A " ± 25ppm ; " B " ± 50ppm ; " C " ± 100ppm ; If non-standard please enter the desired stability after " C " , for example " C15 " : represents ±15ppm over -20 to +70°C
	-40°C ~ 85°C	" D " ± 25ppm ; " E " ± 50ppm ; " F " ± 100ppm ; If non-standard please enter the desired stability after " F " , for example " F20 " : represents ±20ppm over -40 to +85°C
[4]	" T " for Pin 1 option , Leave this space blank if no connection on pad 1.	
[5]	Frequency in MHz	
[6]	Output power in dBm	

HS - series test circuit

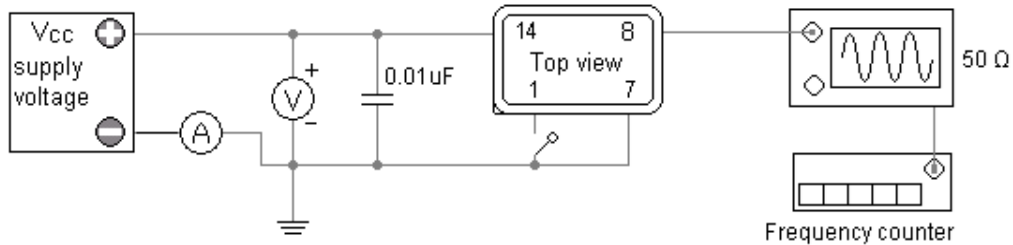

True Sine Waveform

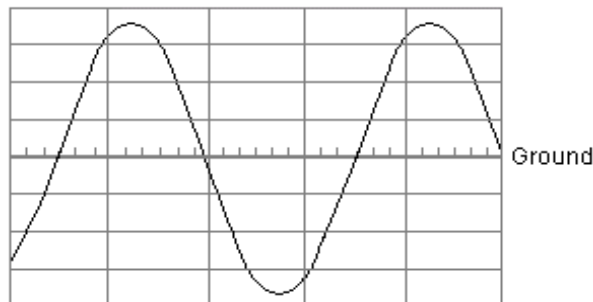

Mercury Crystal Oscillator Products Lineup

General VCXOs Selection Guide [Square Wave Output]

Output Wave Output Logic	Product Series	Supply Voltage	Frequency Range	Product Description / Features
CMOS	G (SMD)	1.8 V / 3.3 V	1.25 ~ 50 MHz	General purpose VCXOs.
	G (Dip)			
	GTQN	2.5 V / 3.3 V	10 ~ 250 MHz	0.6 psec Phase Jitter (typ.)
	GTQF	2.5 V / 3.3 V	10 ~ 250 MHz	1.2 psec Phase Jitter (typ.)
	GCTQF	2.5 V / 3.3 V	10 ~ 250 MHz	Frequency Switchable , 1.5 psec Phase Jitter (typ.)
	GTJFN	1.8 V / 2.5 V / 3.3 V	15 ~ 250 MHz	150 fsec Phase Jitter (typ.)
LVPECL	GPQN	2.5 V / 3.3 V	10 ~ 1,500 MHz	0.6 psec Phase Jitter (typ.)
	GPQF	2.5 V / 3.3 V	10 ~ 1,500 MHz	1.2 psec Phase Jitter (typ.)
	GCPQF	2.5 V / 3.3 V	10 ~ 1,500 MHz	Frequency Switchable , 1.5 psec Phase Jitter (typ.)
	GPJFN	2.5 V / 3.3 V	15 ~ 2,100 MHz	150 fsec Phase Jitter (typ.)
LVDS	GDQN	2.5 V / 3.3 V	10 ~ 1,500 MHz	0.6 psec Phase Jitter (typ.)
	GDQF	2.5 V / 3.3 V	10 ~ 1,500 MHz	1.2 psec Phase Jitter (typ.)
	GCDQF	2.5 V / 3.3 V	10 ~ 1,500 MHz	Frequency Switchable , 1.5 psec Phase Jitter (typ.)
	GDJFN	1.8 V / 2.5 V / 3.3 V	15 ~ 2,100 MHz	150 fsec Phase Jitter (typ.)
CML	GQJFN	1.8 V / 2.5 V / 3.3 V	15 ~ 2,100 MHz	150 fsec Phase Jitter (typ.)
HCSSL	GCJFN	2.5 V / 3.3 V	15 ~ 700 MHz	150 fsec Phase Jitter (typ.)

VCXOs

Frequency Switchable VCXOs [Select f1 or f2 by Toggling Pin 1] [Square Wave Output]

Output Wave Output Logic	Product Series	Supply Voltage	Frequency Range	Product Description / Features
CMOS	GCTQF	2.5 V / 3.3 V	10 ~ 250 MHz	Switchable output Oscillators , 1.5 psec Phase Jitter (typ.)
LVPECL	GCPQF	2.5 V / 3.3 V	10 ~ 1,500 MHz	Switchable output Oscillators , 1.5 psec Phase Jitter (typ.)
LVDS	GCDQF	2.5 V / 3.3 V	10 ~ 1,500 MHz	Switchable output Oscillators , 1.5 psec Phase Jitter (typ.)

VCXO " G "

CMOS

Thru-Hole

SMD

1.8 V

3.3 V

Min.

1.25 MHz

Max.

50.0 MHz

Unlike regular clock oscillators that have a fixed output frequency, the output frequency of VCXOs (also known as " frequency modulators ") can be tuned $\pm 50 \sim \pm 200$ ppm up or down from the nominal frequency, by varying the control voltage on the voltage control pin. A varactor and a voltage variable capacitance tuning diode, is used to achieve this function. Applications include (PLL) phase lock loop, SONET / ATM, set -top boxes, MPEG, audio -video modulations, video game consoles and HDTV sets, ONET, 10GbE, Fibre Channel, wireless repeaters, transponders, HDTV, FPGAs, data acquisition.

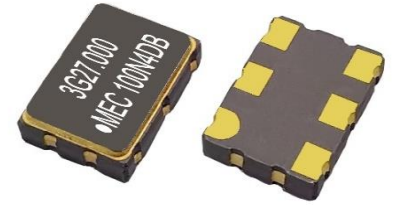

General Specifications of " G " series , [TA = +25°C , V_{DD}= at specified voltage , Load : 15 pF]

Model	" G " series						
Output Waveform	CMOS						
Type	SMD Type				Thru - Hole Type		
Pads / Pins	6 pads				4 pins		
Models (Dimensions) , Unit : mm	G226 (2.5 * 2.0 * 1.0)		G576 (7.0 * 5.0 * 1.7)		G8 (12.8 * 12.8 * 6.3)		
	G326 (3.2 * 2.5 * 1.0)		G536 (5.0 * 3.2 * 1.2)		G14 (20.2 * 12.8 * 6.8)		
Supply Voltage (V _{DD})	+1.8V \pm 5%				+3.3V \pm 10%		
Frequency Range	16.0 MHz ~ 50.0 MHz				1.25 MHz ~ 50.0 MHz		
Initial Freq. Accuracy (at 25 °C)	with V _c = 0.9V				with V _c = 1.65V		
Output Logic High " 1 "	1.62 V (min.)				2.97 V (min.)		
Output Logic Low " 0 "	0.18 V (max.)				0.33 V (max.)		
Frequency Deviation Range	Standard : \pm 80 ppm (min.)				Standard : \pm 80 ppm (min.)		
Control Voltage Center and Range	0.9 V \pm 0.9 V				1.65 V \pm 1.35 V		
Frequency Stability Codes	Frequency Stability over Operating Temperature Range	\pm 25 ppm	\pm 50 ppm	\pm 100 ppm	If non-standard please enter the desired stability after the " C " or " F "		
	Commercial (-20°C to +70°C)	A	B	C	For example :		
	Industrial (-40°C to +85°C)	D	E	F	" C20 " : \pm 20 ppm over -20°C to +70°C ; " F30 " : \pm 30 ppm over -40°C to +85°C		
Output Load	15 pF						
Rise Time (Tr) / Fall Time (Tf)	4 nsec.(typ.) ; 6 nsec.(max.) Measured between 10% to 90% of waveform						
Duty Cycle	50% \pm 10% (standard) , 50% \pm 5% (optional, add " - S " as suffix to part number)						
RMS Jitter (12 KHz to 20 MHz)	1.0 psec (max.)						
Phase Noise	Offset	10 Hz	100 Hz	1K Hz	10K Hz	100K Hz	1 MHz
[27MHz , 3.3V]	dBc/Hz (typ.)	-40 dBc/Hz	-104 dBc/Hz	-132 dBc/Hz	-147 dBc/Hz	-152 dBc/Hz	-150 dBc/Hz
Start-up Time	10 msec. (max.)						
Current Consumption	10 ~ 45 mA (Frequency dependent) . For 27 MHz: 10 mA (typ.) at +3.3 V _{DD}						
Linearity	6% (typ.) ; 10% (max.)						
Modulation Bandwidth	10 KHz (min.) Measured at -3 dB						
Input Impedance	5 M Ω (typ.)						
Slope Polarity (Transfer Function)	Monotonic and Positive : Increasing control voltage always increases output frequency ,						
Storage Temperature	-55°C to +125°C						
Aging at Ta = +25°C	\pm 3 ppm per year (max.)						
Output Enable / Disable Function	Enable	When 70% (min.) of V _{DD} to Enable Output. ; Enable time : 2 msec (max.)					
	Disable	When 30% (max.) of V _{DD} to Disable Output. ; Disable time : 100 nsec (max.)					

Outline Dimensions (Unit : mm) , Suggested pad Layout for SMDs

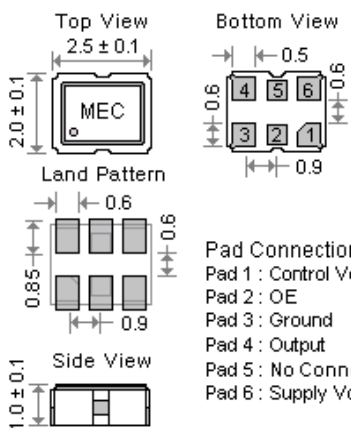
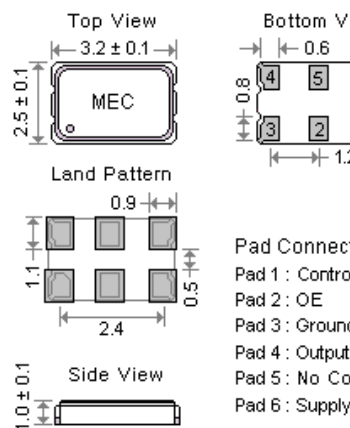
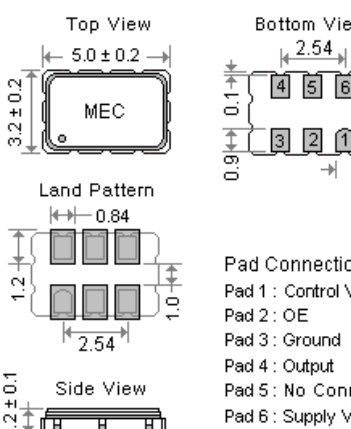
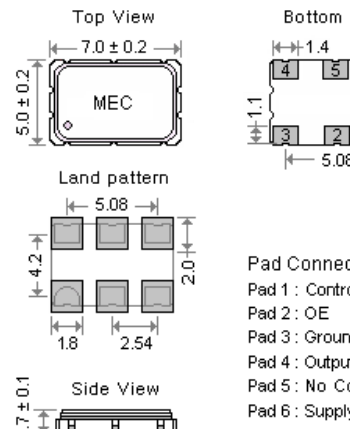
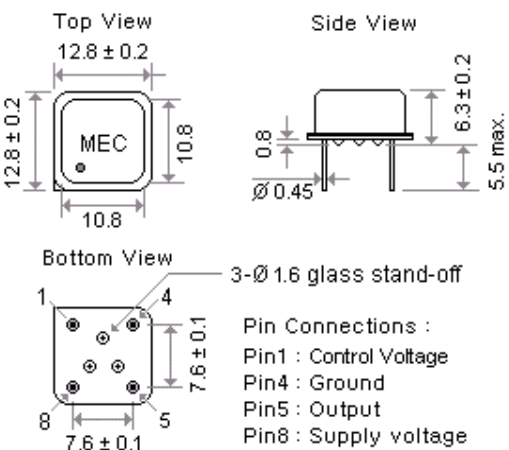
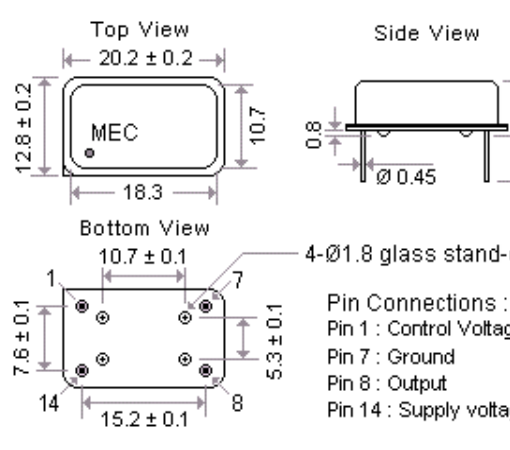
[G226]	[G326]
 <p>Top View: 2.5 ± 0.1, 2.0 ± 0.1</p> <p>Bottom View: 0.5, 0.6, 0.9, 0.6</p> <p>Land Pattern: 0.6, 0.85, 0.9, 0.6</p> <p>Side View: 1.0 ± 0.1</p> <p>Pad Connections : Pad 1 : Control Voltage Pad 2 : OE Pad 3 : Ground Pad 4 : Output Pad 5 : No Connection Pad 6 : Supply Voltage</p>	 <p>Top View: 3.2 ± 0.1, 2.5 ± 0.1</p> <p>Bottom View: 0.6, 0.8, 1.2, 1.5</p> <p>Land Pattern: 0.9, 1.1, 2.4, 0.5</p> <p>Side View: 1.0 ± 0.1</p> <p>Pad Connections : Pad 1 : Control Voltage Pad 2 : OE Pad 3 : Ground Pad 4 : Output Pad 5 : No Connection Pad 6 : Supply Voltage</p>
[G536]	[G576]
 <p>Top View: 5.0 ± 0.2, 3.2 ± 0.2</p> <p>Bottom View: 2.54, 2.1, 0.1, 0.9, 0.64</p> <p>Land Pattern: 0.84, 1.2, 2.54, 1.0</p> <p>Side View: 1.2 ± 0.1</p> <p>Pad Connections : Pad 1 : Control Voltage Pad 2 : OE Pad 3 : Ground Pad 4 : Output Pad 5 : No Connection Pad 6 : Supply Voltage</p>	 <p>Top View: 7.0 ± 0.2, 5.0 ± 0.2</p> <p>Bottom View: 1.4, 1.1, 3.7, 5.08</p> <p>Land Pattern: 5.08, 4.2, 1.8, 2.54, 2.0</p> <p>Side View: 1.7 ± 0.1</p> <p>Pad Connections : Pad 1 : Control Voltage Pad 2 : OE Pad 3 : Ground Pad 4 : Output Pad 5 : No Connection Pad 6 : Supply Voltage</p>
[G8]	[G14]
 <p>Top View: 12.8 ± 0.2, 10.8</p> <p>Side View: 0.8, 6.3 ± 0.2, 5.5 max., Ø 0.45</p> <p>Bottom View: 3-Ø 1.6 glass stand-off, 7.6 ± 0.1</p> <p>Pin Connections : Pin1 : Control Voltage Pin4 : Ground Pin5 : Output Pin8 : Supply voltage</p>	 <p>Top View: 20.2 ± 0.2, 12.8 ± 0.2, 18.3, 10.7</p> <p>Side View: 0.8, 6.8 ± 0.2, 5.5 max., Ø 0.45</p> <p>Bottom View: 10.7 ± 0.1, 7.6 ± 0.1, 15.2 ± 0.1, 5.3 ± 0.1, 4-Ø 1.8 glass stand-off</p> <p>Pin Connections : Pin 1 : Control Voltage Pin 7 : Ground Pin 8 : Output Pin 14 : Supply voltage</p>

VCOs

Part Number Format and Examples

[1]	[2]	[3]	[4]	[5]	[6]
Supply Voltage	Holder Type	Frequency Stability	Pulling Range	Range Code	Center Frequency

Examples	(1)	18	G14	-	B	-	100	N	-	35.328
	(2)	3	G576	-	D	-	80	T	-	27.000

Ex (1) : **18G14 - B - 100N - 35.328** [+1.8V , full size 4 pin Dip type , ±50ppm (-20°C to 70°C) , pulling : ±100 ppm (min.) , 35.328 MHz]

Ex (2) : **3G576 - D - 80T - 27.000** [+3.3V , G576 type , ±25ppm (-40°C to 85°C) , pulling : ±80 ppm (typ.) , 27.000 MHz]

[1]	Supply voltage , " 18 " for +1.8V ; " 3 " for +3.3V	
[2]	Holder Type	
[3]	-20°C ~ 70°C	" A " ± 25ppm ; " B " ± 50ppm ; " C " ± 100ppm ; If non-standard please enter the desired stability after " C " , for example " C15 " : represents ±15ppm over -20 to +70°C
	-40°C ~ 85°C	" D " ± 25ppm ; " E " ± 50ppm ; " F " ± 100ppm ; If non-standard please enter the desired stability after " F " , for example " F20 " : represents ±20ppm over -40 to +85°C
[4]	Frequency Pulling Range	3.3V From ±30ppm ~ ±150ppm , control Voltage range : 0.3V ~ 3.0 ; control voltage center : ± 1.65 V
		5.0V From ±70ppm ~ ±200ppm , control Voltage range : 0.5V ~ 4.5V ; control voltage center : ± 2.5 V
[5]	Pulling Range Code	" M " stands for maximum ; " N " stands for minimum ; " T " stands for typical (tolerance is ± 20%)
[6]	Center Frequency in MHz	

CMOS Output Waveform

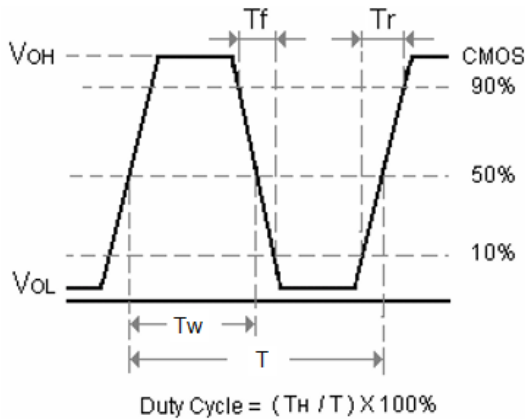

Transfer Function

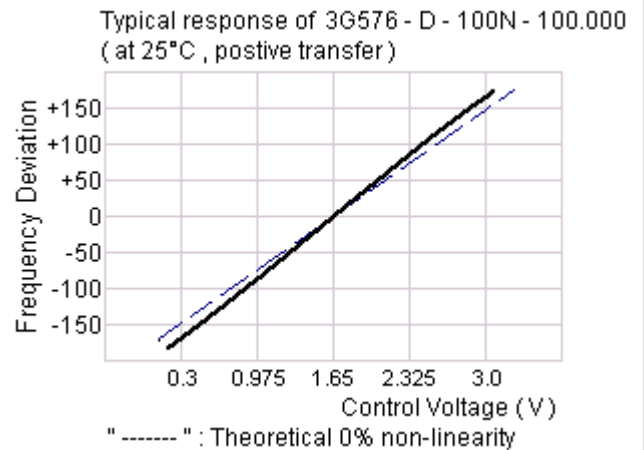

[Thru - Hole Type] CMOS Square Wave Test Circuit

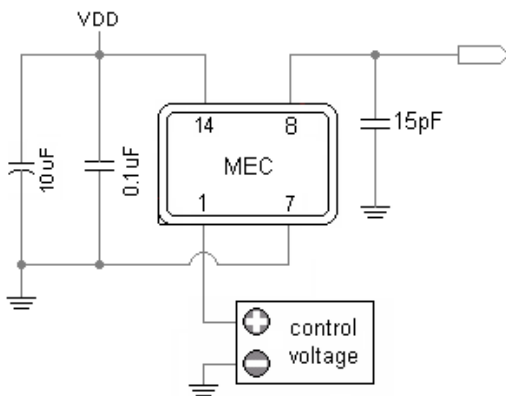

[SMD 6 pads] CMOS Square Wave Test Circuit

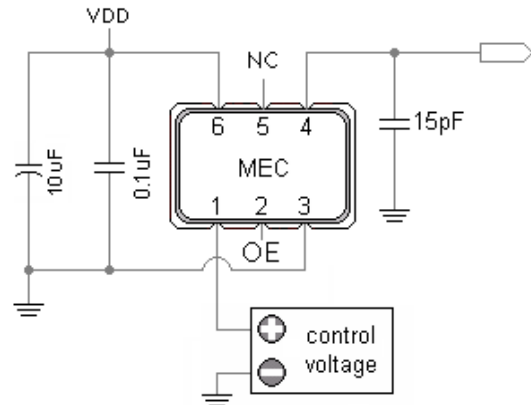

GTQN

CMOS Waveform

GPQN

LVPECL Differential

GDQN

LVDS Differential

0.6 ps
RMS Jitter

SMD

2.5 V 3.3 V

Min.

10 MHz

Max.

1,500 MHz

Features

- Output frequency range : 10 MHz to 1500 MHz
- Low RMS Jitter 0.6 ps typical (12KHz to 20MHz)
- Package size : 3.2x2.5mm , 5.0x3.2mm , 7.0x5.0mm
- If you need lower rms jitter, please refer to the "G_JFN" series (150 fsec typ. @ 12KHz to 20MHz)

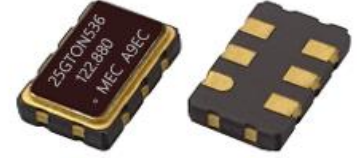

General specifications , at Ta=+25°C , CL=15pF

Model	GTQN		GPQN			GDQN		
Output Logic	CMOS		LVPECL			LVDS		
Supply Voltage V _{DD} (code)	+ 2.5 V ± 5% (voltage code " 25 ")		+ 2.5 V ± 5% (voltage code " 25 ")			+ 2.5 V ± 5% (voltage code " 25 ")		
	+ 3.3 V ± 5% (voltage code " 33 ")		+ 3.3 V ± 5% (voltage code " 33 ")			+ 3.3 V ± 5% (voltage code " 33 ")		
Available Frequency Range	10 ~ 250 MHz		10 ~ 1,500 MHz			10 ~ 1,500 MHz		
Output Load	15 pF		RL = 50 Ω to (V _{DD} -2.0V). See test circuit below.			100 Ω between OUT and OUTN		
Output Logic " High " , " 1 "	90 % V _{DD}		V _{DD} - 1.03 (min.) , V _{DD} - 0.6 (max.)			1.4 V (Typ.) , 1.6 V (max.)		
Output Logic " Low " , " 0 "	10 % V _{DD}		V _{DD} - 1.85 (min.) , V _{DD} - 1.6 (max.)			1.1 V (Typ.) , 0.9 V (min.)		
Current with Output Disable	16 mA (typ.)		16 mA (typ.)			16 mA (typ.)		
Current Consumption (V _{DD} = + 3.3V)	10 ~ 50 MHz : 30 mA		10 ~ 250 MHz : 50 mA			10 ~ 250 MHz : 30 mA		
	51 ~ 150 MHz : 38 mA		251 ~ 750 MHz : 55 mA			251 ~ 750 MHz : 34 mA		
	151 ~ 250 MHz : 48 mA		751 ~ 1,500 MHz : 60 mA			751 ~ 1,500 MHz : 40 mA		
Rise Time / Fall Time	10 nsec. (max.)		0.5 nsec. (max.)			0.4 nsec. (max.)		
	Tr / Tf : 10% ↔ 90% waveform		Tr / Tf : 20% ↔ 80% waveform			Tr / Tf : 20% ↔ 80% waveform		
Duty Cycle	50% ± 5%							
Start-up Time	10 msec. (max.)							
Aging at Ta = +25°C	± 5 ppm (max.) for first year							
Storage Temperature	-55°C to +150°C							
Frequency Stability Codes	Frequency Stability		± 25 ppm	± 50 ppm	± 100 ppm	If non-standard , please enter the desired Stability after the " C " or " F " represents . For example : " C20 " ± 20 ppm over -20°C to +70°C ; " F20 " ± 20 ppm over -40°C to +85°C		
	Over Operating Temperature Range							
	Commercial (-20°C to +70°C)	A	B	C				
Industrial (-40°C to +85°C)	D	E	F					
RMS Jitter [12 KHz ~ 20 MHz]	0.6 psec (typ.)							
Phase Noise [dBc / Hz (typ.)]	Offset	10 Hz	100 Hz	1 KHz	10 KHz	100 KHz	1 MHz	10 MHz
	125 MHz	-63	-94	-113	-122	-126	-137	-156
	212.5 MHz	-55	-85	-108	-117	-120	-132	-156
Control Voltage Function on Pad 1								
Supply Voltage	V _{DD} = +2.5 V ; Vcon Center = +1.25V				V _{DD} = +3.3 V ; Vcon Center = +1.65V			
Vcontrol Range	+ 0.25V ~ +2.25V				+ 0.3V ~ +3.0V			
Frequency Pulling Range	± 80 ppm (min.)				± 80 ppm (min.)			
	Up to ± 200 ppm (min.) is also available. Please contact Mercury.							
Linearity	5% (typ.) ; 10% (max.)							
Transfer Function	Positive Transfer							
Input Impedance	1 MΩ (typ.)							
Bandwidth	10 KHz (min.) Measured at -3 dB							
Output Enable Function on Pad 2								
OE Control on Pad 2	70% of V _{DD} (min.) to enable output. (Open connection prohibit)							
	30% of V _{DD} (max.) to disable output.							
Output Enable Time / Disable Time	200 nsec. (max.) / 50 nsec. (max.)							

Voltage Controlled Crystal Oscillators

GTQF

CMOS Waveform

GPQF

LVPECL Differential

GDQF

LVDS Differential

Q family

F series

SMD

2.5 V

3.3 V

Min.

10 MHz

Max.

1,500 MHz

Features

- The GTQF, GPQF and GDQF Series are members of Mercury's Q-Family Quick-Turn crystal oscillators
- Output frequency range : 10 MHz to 1500 MHz
- Low RMS jitter 1.2 ps typical (12KHz to 20MHz)
- Package size : 3.2x2.5mm , 5.0x3.2mm , 7.0x5.0mm
- Next-day samples for prototypes

Quick - Turn Clock Oscillators

1.2 pS Phase Jitter (typical)

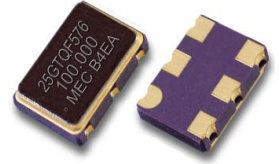

General specifications , at Ta=+25°C

Model	GTQF	GPQF	GDQF
Output Logic	CMOS	LVPECL	LVDS
Supply Voltage V _{DD} (code)	+ 2.5 V ± 5% (voltage code " 25 ") + 3.3 V ± 5% (voltage code " 3 ")	+ 2.5 V ± 5% (voltage code " 25 ") + 3.3 V ± 5% (voltage code " 3 ")	+ 2.5 V ± 5% (voltage code " 25 ") + 3.3 V ± 5% (voltage code " 3 ")
Available Frequency Range	10 ~ 250 MHz	10 ~ 1,500 MHz	10 ~ 1,500 MHz
Output Load	15 pF	50 Ω into V _{DD} - 2V or Thevenin equivalent	100 Ω between OUT and OUTN
Output Logic " High " , " 1 "	90 % V _{DD}	V _{DD} - 1.03 (min.) , V _{DD} - 0.6 (max.)	1.4 V (Typ.) , 1.6 V (max.)
Output Logic " Low " , " 0 "	10 % V _{DD}	V _{DD} - 1.85 (min.) , V _{DD} - 1.6 (max.)	1.1 V (Typ.) , 0.9 V (min.)
Current with Output Disable	16 mA (typ.)	16 mA (typ.)	16 mA (typ.)
Current Consumption (V _{DD} = + 3.3V)	10 ~ 50 MHz : 30 mA	10 ~ 250 MHz : 50 mA	10 ~ 250 MHz : 30 mA
	51 ~ 150 MHz : 38 mA	251 ~ 750 MHz : 55 mA	251 ~ 750 MHz : 34 mA
	151 ~ 250 MHz : 48 mA	751 ~ 1,500 MHz : 60 mA	751 ~ 1,500 MHz : 40 mA
Rise Time / Fall Time	1.5 nsec. (Typ.) , 3.0 nsec. (max.) Tr / Tf : 10% ↔ 90% waveform	0.2 nsec. (Typ.) , 0.5 nsec. (max.) Tr / Tf : 20% ↔ 80% waveform	0.2 nsec. (Typ.) , 0.4 nsec. (max.) Tr / Tf : 20% ↔ 80% waveform

Duty Cycle	50 % ± 5%							
Start-up Time	10 msec. (max.)							
Aging at Ta = +25°C	± 2 ppm (max.) first year at 25°C ; ± 10 ppm (max.) over 10 years							
Storage Temperature	-55°C to +150°C							
Frequency Stability Codes	Frequency Stability	± 25 ppm	± 50 ppm	± 100 ppm	If non-standard , please enter the desired Stability after the " C " or " F " represents . For example : " C20 " ± 20 ppm over -20°C to +70°C ; " F20 " ± 20 ppm over -40°C to +85°C			
	Over Operating Temperature Range							
	Commercial (-20°C to +70°C)	A	B	C				
	Industrial (-40°C to +85°C)	D	E	F				
RMS Jitter [12 KHz ~ 20 MHz]	1.2 psec (typ.)							
Phase Noise [dBc / Hz (typ.)]	Offset	10 Hz	100 Hz	1 KHz	10 KHz	100 KHz	1 MHz	10 MHz
	156.250 MHz	-55	-85	-109	-116	-118	-139	-146
	491.52 MHz	-61	-86	-100	-105	-105	-126	-137

Control Voltage Function on Pad 1

Supply Voltage	V _{DD} = +2.5 V ; Vcon Center = +1.25V	V _{DD} = +3.3 V ; Vcon Center = +1.65V
Vcontrol Range	+ 0.25V ~ +2.25V	+ 0.3V ~ +3.0V
Frequency Pulling Range	± 80 ppm (min.)	± 80 ppm (min.)
	Up to ± 200 ppm (min.) is also available. Please contact Mercury.	
Linearity	5% (typ.) ; 10% (max.)	
Transfer Function	Positive Transfer	
Input Impedance	1 MΩ (typ.)	
Bandwidth	10 KHz (min.) Measured at -3 dB	

Output Enable Function on Pad 2

OE Control on Pad 2	70% of V _{DD} (min.) to enable output. (Open connection prohibit)
	30% of V _{DD} (max.) to disable output.
Output Enable Time / Disable Time	200 nsec. (max.) / 50 nsec. (max.)

Voltage Controlled Crystal Oscillators [VCXO]

GTQN , GTQF [CMOS Waveform]

GPQN , GPQF [LVPECL Differential]

GDQN , GDQF [LVDS Differential]

Part Number Format and Example

	[1]	[2]		[3]		[4]	[5]		[6]
	Supply Voltage	Holder Type	-	Frequency Stability	-	Pulling Range	Range Code	-	Center Frequency

Examples	(1)	3	GTQN576	-	C20	-	150	M	-	200.000
	(2)	25	GDQF536	-	D	-	100	N	-	135.000

Ex (1) : **3GTQN576 - C20 - 150M - 200.000** [+3.3V, GTQN576 type, ±20ppm (-20°C to 70°C), Pulling : ±150ppm (max.), 200.000 MHz]

Ex (2) : **25GDQF536 - D - 100N - 135.000** [+2.5V, GDQF536 type, ±25ppm (-40°C to 85°C), Pulling : ±100 ppm (min.), 135.000 MHz]

[1]	Supply voltage, " 25 " for +2.5V ; " 3 " for +3.3V	
[2]	Holder Type	
[3]	-20°C ~ 70°C	" A " ± 25ppm ; " B " ± 50ppm ; " C " ± 100ppm ; If non-standard please enter the desired stability after " C ", for example " C20 " : represents ±20ppm over -20 to +70°C
	-40°C ~ 85°C	" D " ± 25ppm ; " E " ± 50ppm ; " F " ± 100ppm ; If non-standard please enter the desired stability after " F ", for example " F20 " : represents ±20ppm over -40 to +85°C
[4]	Frequency Pulling Range	
[5]	Pulling Range Code	" M " stands for maximum ; " N " stands for minimum ; " T " stands for typical (tolerance is ± 20%)
[6]	Center Frequency in MHz	

Outline Dimensions (Unit : mm) , Suggested pad Layout for SMDs

G_QN326 , G_QF326	G_QN536 , G_QF536	G_QN576 , G_QF576

Pad Connections :

Pad 1 : VCXO	Pad 2 : OE: High Enable	Pad 3 : Ground
Pad 4 : [CMOS : Output , LVPECL or LVDS : Differential]	Pad 5 : [CMOS : NC , LVPECL or LVDS : Complementary]	Pad 6 : Supply Voltage

Test Circuits and Output Waveforms

CMOS Test Circuit	LVPECL Test Circuit	LVDS Test Circuit
	<p style="text-align: center;"> $V_{DD} = 3.3V ; R1 = R3 = 127 \Omega ; R2 = R4 = 82.5 \Omega$ $V_{DD} = 2.5V ; R1 = R3 = 250 \Omega ; R2 = R4 = 62.5 \Omega$ </p>	

Switchable Output Crystal Oscillators

GCTQF

CMOS Waveform

GCPQF

LVPECL Differential

GCDQF

LVDS Differential

**Frequency
Switchable**
SMD
2.5 V
3.3 V
Min.
10 MHz
Max.
1,500 MHz
Features
Quick - Turn Clock Oscillators

- The GCTQF, GCPQF and GCDQF Series are members of Mercury's Q-Family Quick-Turn crystal oscillators
- Output frequency range : 10 MHz to 1500 MHz
- Package size : 3.2x2.5mm , 5.0x3.2mm , 7.0x5.0mm
- Next-day samples for prototypes



General specifications , at Ta = + 25°C

Model	GCTQF		GCPQF		GCDQF	
Output Logic	CMOS		LVPECL		LVDS	
Supply Voltage V _{DD} (code)	+ 2.5 V ± 5% (voltage code " 25 ")		+ 2.5 V ± 5% (voltage code " 25 ")		+ 2.5 V ± 5% (voltage code " 25 ")	
	+ 3.3 V ± 5% (voltage code " 3 ")		+ 3.3 V ± 5% (voltage code " 3 ")		+ 3.3 V ± 5% (voltage code " 3 ")	
Available Frequency Range	10 ~ 250 MHz		10 ~ 1,500 MHz		10 ~ 1,500 MHz	
Output Load	15 pF		50 Ω into V _{CC} - 2V or Thevenin equivalent		100 Ω between output and complimentary output	
Output Logic " High " , " 1 "	90 % V _{DD}		V _{DD} - 1.03 (min.) , V _{DD} - 0.6 (max.)		1.4 V (Typ.) , 1.6 V (max.)	
Output Logic " Low " , " 0 "	10 % V _{DD}		V _{DD} - 1.85 (min.) , V _{DD} - 1.6 (max.)		1.1 V (Typ.) , 0.9 V (min.)	
Current Consumption (V _{DD} : + 2.5 V)	10 ~ 100 MHz : 30 mA (max.)		10 ~ 600 MHz : 45 mA (max.)		10 ~ 600 MHz : 30 mA (max.)	
	101 ~ 250 MHz : 40 mA (max.)		601 ~ 1,500 MHz : 55 mA (max.)		601 ~ 1,500 MHz : 35 mA (max.)	
Current Consumption (V _{DD} : + 3.3 V)	10 ~ 100 MHz : 35 mA (max.)		10 ~ 600 MHz : 50 mA (max.)		10 ~ 600 MHz : 35 mA (max.)	
	101 ~ 250 MHz : 40 mA (max.)		601 ~ 1,500 MHz : 60 mA (max.)		601 ~ 1,500 MHz : 40 mA (max.)	
Current with Output Disabie	18 mA (Typ.)		18 mA (Typ.)		18 mA (Typ.)	
Rise Time / Fall Time	10.0 nsec. (max.)		0.5 nsec. (max.)		0.4 nsec. (max.)	
	Tr / Tf : 10% ↔ 90% waveform		Tr / Tf : 20% ↔ 80% waveform		Tr / Tf : 20% ↔ 80% waveform	
RMS Jitter [12 KHz ~ 20 MHz]	1.5 psec (typ.)					
Duty Cycle	50% ± 5%					
Start-up Time	10 msec. (max.)					
Aging at Ta = +25°C	± 2 ppm (max.) first year at 25°C ; ± 10 ppm (max.) over 10 years					
Storage Temperature	-55°C to +150°C					
Frequency Stability Codes	Frequency Stability over Operating Temperature Range	± 25 ppm	± 50 ppm	± 100 ppm	If non-standard , please enter the desired stability after the " C " or " F " represents . For example : " C20 " ± 20 ppm over -20°C to +70°C ; " F20 " ± 20 ppm over -40°C to +85°C	
	Commercial (-20°C to +70°C)	A	B	C		
	Industrial (-40°C to +85°C)	D	E	F		
Control Voltage Function on Pad 1						
Supply Voltage	V _{DD} = +2.5 V ; Vcon Center = +1.25V			V _{DD} = +3.3 V ; Vcon Center = +1.65V		
Vcontrol Range	+ 0.25V ~ +2.25V			+ 0.3V ~ +3.0V		
Frequency Pulling Range	± 80 ppm (min.)			± 80 ppm (min.)		
	Up to ± 200 ppm (min.) is also available. Please contact Mercury.					
Linearity	5% (typ.) ; 10% (max.)					
Transfer Function	Positive Transfer					
Input Impedance	1 MΩ (typ.)					
Bandwidth	10 KHz (min.) Measured at -3 dB					
Frequency Selection Function on Pad 2						
FSEL on pad2	70% of V _{DD} (min.) For FSEL = 1 , Output frequency is Freq.2 (f2)					
	30% of V _{DD} (max.) For FSEL = 0 , Output frequency is Freq.1 (f1)					
	Default FSEL pin has internal pull-up resistor .					
	Frequency switching time : 60 us (typ.)					

VCXOs

Switchable Output Crystal Oscillators

GCTQF

CMOS Waveform

GCPQF

LVPECL Differential

GCDQF

LVDS Differential

Frequency Switchable

SMD

2.5 V

3.3 V

Min.

10 MHz

Max.

1,500 MHz

Part Number Format and Example

Quick - Turn Clock Oscillators

Example : 3GCTQF576 - E - 80N - 30.000 / 120.000

3	GCTQN	576	-	E	-	80N	-	30.000	/	120.000
Supply Voltage "3" for 3.3V "25" for 2.5V	GCTQF : CMOS GCPQF : LVPECL GCDQF : LVDS	Package Size "576": 7 x 5 mm "536": 5 x 3.2 mm "326": 3 x 2.5 mm	-	Frequency Stability Code "E": ±50 ppm over -40 to +85°C. Other frequency stabilities are available.	-	±80 ppm (min.) frequency pulling range.	-	Custom Frequency 1 FSEL = 0 (MHz)	-	Custom Frequency 2 FSEL = 1 (MHz)

Outline Dimensions (Unit : mm) , Suggested pad Layout for SMDs

GC_QF326	GC_QF536	GC_QF576

Pad Connections :

Pad 1 : Control Voltage ; Pad 2 : Frequency Selection [FSEL = 0 (f 1) , FSEL = 1 (f 2)] ; Pad 3 : Ground

Pad 4 : [CMOS : Output , LVPECL or LVDS : Differential] ; Pad 5 : [CMOS : NC , LVPECL or LVDS : Complementary] ; Pad 6 : Supply Voltage

Test Circuits and Output Waveforms

CMOS Test Circuit	LVPECL Test Circuit	LVDS Test Circuit
<p>FSEL = High Output : f 2 FSEL = Low Output : f 1</p>	<p>FSEL = High Output : f 2 FSEL = Low Output : f 1</p> <p>V_{DD} = 3.3V ; R1 = R3 = 127 Ω ; R2 = R4 = 82.5 Ω V_{DD} = 2.5V ; R1 = R3 = 250 Ω ; R2 = R4 = 62.5 Ω</p>	<p>FSEL = High Output : f 2 FSEL = Low Output : f 1</p>
CMOS Output Waveform	LVPECL Output Waveform	LVDS Output Waveform

High Frequency Ultra-low Jitter Voltage Controlled Crystal Oscillators [Quick - Turn VCXO , 15 ~ 2,100 MHz]

G_JFN

CMOS / Differential

**Quick - Turn
Clock Oscillators**

**150 fsec
RMS Jitter**

SMD

1.8 V

2.5 V

3.3 V

Min.

15 MHz

Max.

2,100 MHz

Features

- High Frequency Range : 15 ~ 2,100 MHz
- Ultra-low RMS Jitter : 150 fsec (typ.) @ 3.3V , 156.250 MHz
- Package Size : 5.0 x 3.2mm and 7.0 x 5.0mm
- Next-Day sample for Prototypes

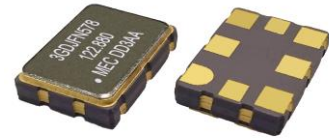

General specifications , at Ta=+25°C

Model	GTJFN	GPJFN	GDJFN	GCJFN	GQJFN
Output Logic	CMOS	LVPECL	LVDS	HCSL	CML
Supply Voltage V _{DD}	+ 1.8 V ± 5%	---	+ 1.8 V ± 5% (*1)	+ 1.8 V ± 5%	+ 1.8 V ± 5%
	+ 2.5 V ± 10%	+ 2.5 V ± 10%	+ 2.5 V ± 10%	+ 2.5 V ± 10%	+ 2.5 V ± 10%
	+ 3.3 V ± 10%	+ 3.3 V ± 10%	+ 3.3 V ± 10%	+ 3.3 V ± 10%	+ 3.3 V ± 10%
Available Frequency Range	15 ~ 250 MHz	15 ~ 2,100 MHz	15 ~ 2,100 MHz	15 ~ 700 MHz	15 ~ 2,100 MHz
Output Load	15pF (max.)	50 Ω into V _{DD} - 2V or Thevenin equivalent	100 Ω between OUT and OUTN	50 Ω to GND	50 Ω to V _{DD}
Output Logic " High " , " 1 "	V _{DD} - 0.4 V (min.)	V _{DD} - 1.165 V (min.) V _{DD} - 0.8 V (max.)	V _{DD} : 1.4 V (typ.) V _{DD} : 1.6 V (max.)	V _{DD} : 0.66 V (min.) V _{DD} : 1.15 V (max.)	V _{DD} - 0.085 V (min.) V _{DD} = (max.)
Output Logic " Low " , " 0 "	V _{DD} x 0.1 V (max.) 0.3V (max.) for 1.8V only	V _{DD} - 2.0 V (min.) V _{DD} - 1.55 V (max.)	V _{DD} : 1.1 V (typ.) V _{DD} : 0.9 V (min.)	V _{DD} : - 0.15 V (min.) V _{DD} : 0.15 V (max.)	V _{DD} - 0.6 V (min.) V _{DD} - 0.32 V (max.)
Output Voltage Swing	---	595 mV (min.) 930 mV (max.)	250 mV (min.) 450 mV (max.)	450 mV (min.) 700 mV (typ.)	200 mV (min.) 600 mV (max.)
Current Consumption (V _{DD} = + 3.3 V)	75 mA (typ.) 90 mA (max.)	100 mA (typ.) 120 mA (max.)	75 mA (typ.) 90 mA (max.)	80 mA (typ.) 100 mA (max.)	70 mA (typ.) 85 mA (max.)
Current with Output Disabled	62 mA (typ.)	99 mA (typ.)	74 mA (typ.)	79 mA (typ.)	69 mA (typ.)
Rise Time / Fall Time (20% to 80% Waveform)	5.0 nsec (max.) (10% to 90% Waveform)	0.4 nsec (max.)	0.4 nsec (max.)	0.4 nsec (max.)	0.4 nsec (max.)

RMS Jitter [12 KHz ~ 20 MHz]	156.250 MHz : 159 fsec (typ.) ; 491.520 MHz : 155 fsec (typ.) ; 644.530 MHz : 151 fsec (typ.) ; 2,000 MHz : 163 fsec (typ.)				
Frequency Stability Codes	Frequency Stability Over Operating Temperature Range	± 25 ppm		± 50 ppm	± 100 ppm
	Commercial (-20°C to +70°C)	A		B	C
	Industrial (-40°C to +85°C)	D		E	F
	Extended Industrial (-40°C to +105°C)	---		H	J
Duty Cycle	50 % ± 5% ; 50 % ± 10% for CMOS 1.8V only				
Start-up Time	5 msec. (typ.) ; 10 msec. (max.)				
Aging at Ta = +25°C	± 3 ppm (max.) for first year ; ± 2 ppm (max.) per year thereafter				
Storage Temperature	-55°C to +150°C				

Control Voltage Function on Pad 1

Vcontrol Center	+ 0.9 V for V _{DD} = + 1.8 V	+ 1.25 V for V _{DD} = + 2.5 V	+ 1.65 V for V _{DD} = + 3.3 V
Vcontrol Range	+ 0.0 V ~ + 1.8 V	+ 0.25 V ~ + 2.25 V	+ 0.3 V ~ + 3.0 V
Frequency Pulling Range	± 100 ppm (min.) ± 200 ppm (available)	± 100 ppm (min.) ± 200 ppm (available)	± 100 ppm (min.) ± 200 ppm (available)
Linearity	1% (typ.) ; 10% (max.)		
Transfer Function	Positive Transfer		
Input Impedance	5 MΩ (min.)		
Bandwidth	10 KHz (typ.) Measured at -3 dB		

Output Enable Function on Pad 2

Output Enable / Disable Function	80% of V _{DD} (min.) to enable output.
	20% of V _{DD} (max.) to disable output.
Output Enable Time / Disable Time	2.5 msec (max.) / 10 usec (max.)

Note * 1 : This needs AC coupling (100-nF series capacitor). Please check the test circuit.

G_JFN

CMOS / Differential

**Quick - Turn
Clock Oscillators**

**150 fsec
RMS Jitter**

SMD

1.8 V

2.5 V

3.3 V

Min.

15 MHz

Max.

2,100 MHz

Part Number Format and Example

Example : 3GPJFN578-E-150N-644.530

3	G	P	JFN578	-	E	-	150N	-	644.530
Supply Voltage Code : "3" for 3.3V "25" for 2.5V "18" for 1.8V	"G" : for Voltage Controlled Crystal Oscillators	Output Code : "T" : COMS "P" : LVPECL "D" : LVDS "C" : HCSL "Q" : CML	"JFN" : Product Series "578" : Package Code 7.0 * 5.0 _ 8 Pad "538" : Package Code 5.0 * 3.2 _ 8 Pad	-	Freq. Stability Code : "E" : ±50 ppm over -40 to +85 C Other frequency stabilities are available.	-	Freq. Pulling Range : "150" : ±150ppm "M" : Maximum "N" : Minimum "T" : Typical	-	Frequency (MHz)

Outline Dimensions (Unit : mm) , Suggested pad Layout for SMDs

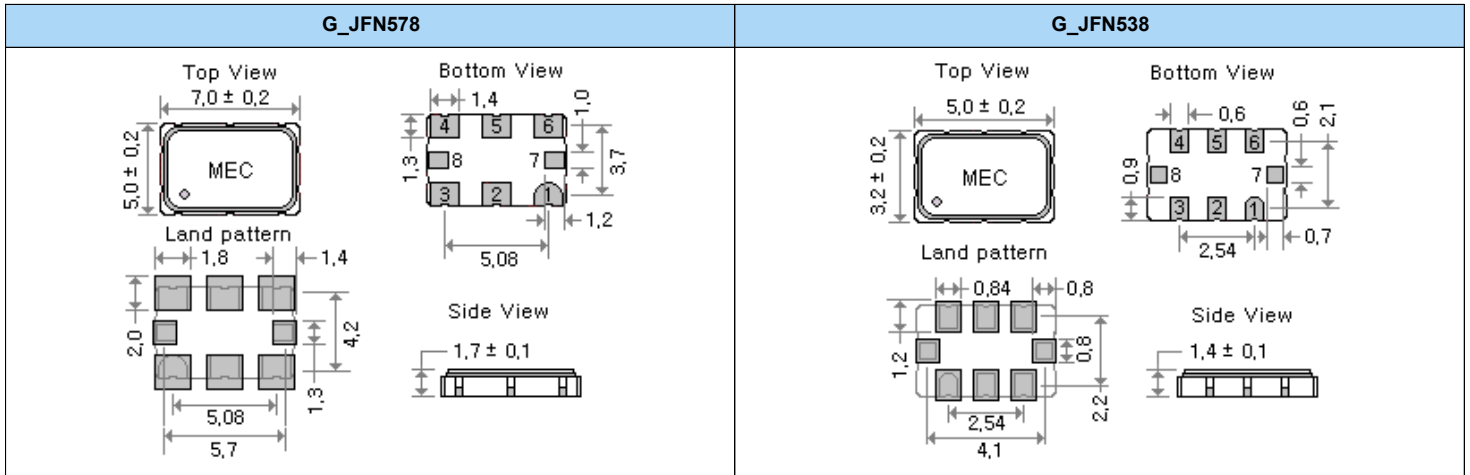

Pad Connections :

Pad 1 : Control Voltage	Pad 2 : Output Enable	Pad 3 : Ground	Pad 4 : CMOS : Output , Differential : Output
Pad 5 : CMOS : No Connection , Differential : Complementary Output	Pad 6 : Supply Voltage	Pad 7 , Pad 8 : Do Not Connect	

Test Circuits

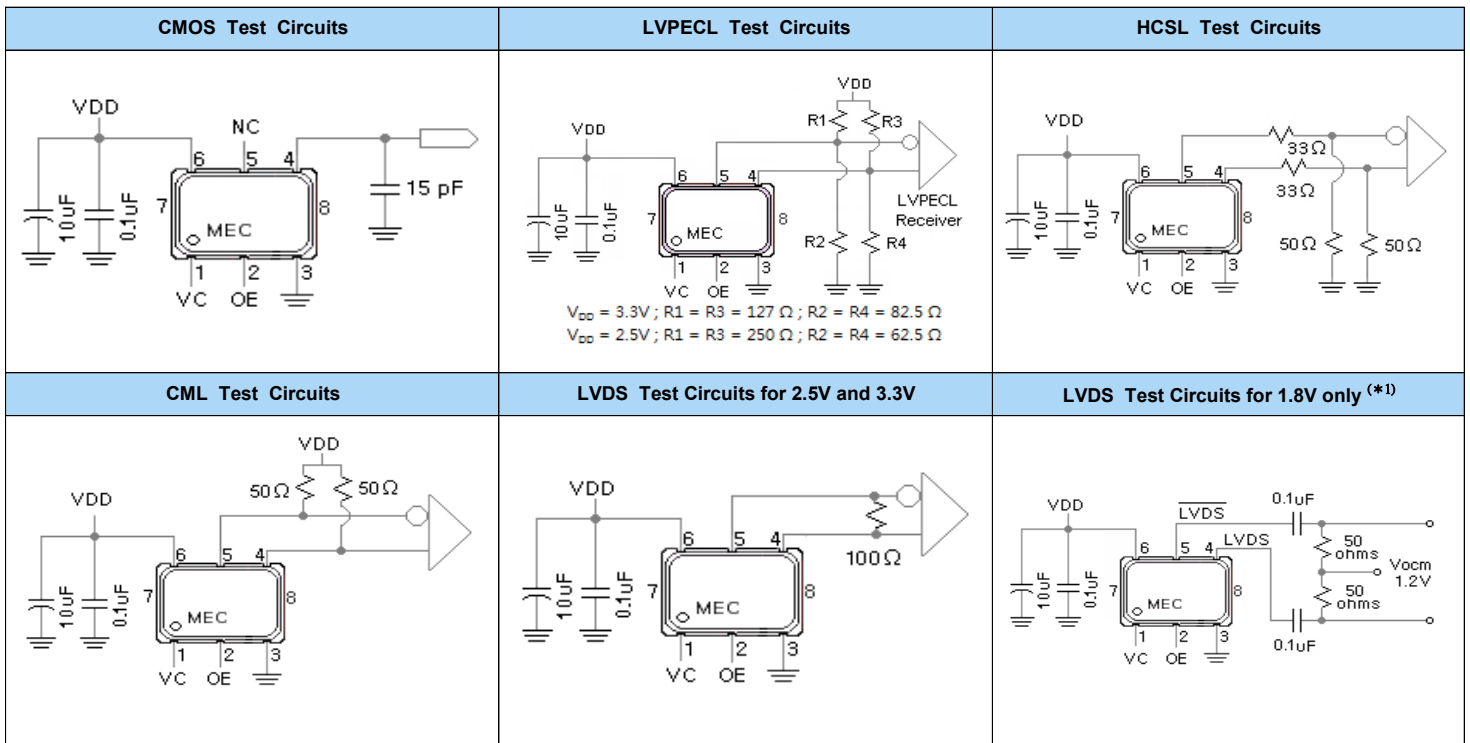

Temperature Compensated Crystal Oscillators [TCXO " M " and VCTCXO " VM "]

Output Waveform : Clipped Sine Wave " S "

Product Summary :

Product Selection Guide

TCXO	VCTCXO	Available Freq. Range	RoHS Compliant Equivalent Model		Package Description
● Leadless Surface Mount Types					
M21S_	VM21S_	10.0 ~ 52.0 MHz	Same		4 pad ceramic substrate SMD. (2.05 x 1.65 x 0.70 mm)
M22S_	VM22S_	10.0 ~ 52.0 MHz	Same		4 pad ceramic substrate SMD. (2.5 x 2.0 x 0.8 mm)
M32S_	VM32S_	8.192 ~ 52.0 MHz	Same		4 pad ceramic substrate SMD. (3.2 x 2.5 x 1.2 mm)
M53S_	VM53S_	6.4 ~ 52.0 MHz	Same		4 pad ceramic substrate SMD. (5.0 x 3.2 x 1.3 mm)
M53S_AB	VM53S_AB	10.0 ~ 52.0 MHz	M53S_AB	VM53S_AB	4 pad FR4 substrate SMD. (5.0 x 3.2 x 1.3 mm)
M57S_	VM57S_	6.4 ~ 52.0 MHz	Same		4 pad ceramic substrate SMD. (7.0 x 5.0 x 2.0 mm)
M57S_AB	VM57S_AB	6.4 ~ 52.0 MHz	M57S_AB	VM57S_AB	4 pad FR4 substrate SMD. (7.0 x 5.0 x 1.4 mm)
M572S_	VM572S_	6.4 ~ 52.0 MHz	Same		4 pad ceramic substrate SMD. (7.0 x 5.0 x 2.3 mm)
● Thru - hole Types					
M39S_	VM39S_	6.4 ~ 52.0 MHz	M39S_	VM39S_	Dip Type 4 pins for VCTCXOs 3 pins for TCXOs
M14S_	VM14S_	6.4 ~ 52.0 MHz	M14S_	VM14S_	Dip Type (4 pins) , Hermetically Sealed
M15S_	VM15S_	6.4 ~ 52.0 MHz	M15S_	VM15S_	Dip Type (4 pins) , With Trimmer
M8S_	VM8S_	6.4 ~ 52.0 MHz	M8S_	VM8S_	Dip Type (4 pins) , Half size , Hermetically Sealed
M9S_	VM9S_	6.4 ~ 52.0 MHz	M9S_	VM9S_	Dip Type (4 pins) , With Trimmer

● “ _ ” is voltage code. Please see the table on next page.

Note: Frequency tuning by the built-in mechanical trimmer is standard for all models except for (V)M57S, (V)M53S and (V)M32S.

Product Options :

● No mechanical trimmer models are available to allow for aqueous washing cycles . To order such option

Note: Non-hermetically sealed (VC)TCXO products are not subject to the washing cycles as the solvent will degrade the trimmer capacitor .

If cleaning is mandatory please choose hermetically sealed packages or no-trimmer option.

Temperature Compensated Crystal Oscillators [TCXO " M " and VCTCXO " VM "]

Clipped Sine Wave ; Waveform Code " S " [SMD Type]

Features

- Frequency stability as tight as ± 0.5 ppm over -30°C to 85°C
- Frequency stability as tight as ± 1.0 ppm over -40°C to 85°C

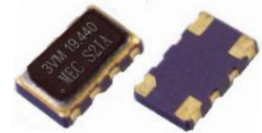

General Specifications [$T_A = +25^{\circ}\text{C}$, $V_{DD} =$ at specified voltage , Load : 10K ohms//10 pF]

Output Waveform		Clipped Sine wave . Waveform code is " S "						
Suggested package		M21S , VM21S	M22S , VM22S	M32S , VM32S	M53S , VM53S			
Package size		2.05 x 1.65 x 0.70 mm	2.5 x 2.0 x 0.8 mm	3.2 x 2.5 x 1.2 mm	5.0 x 3.2 x 1.3 mm			
Supply voltage (V_{DD}) [unit : V]		1.8 , 2.5 , 2.8 , 3.0 , 3.3	1.8 , 2.5 , 2.8 , 3.0 , 3.3	1.8 , 2.5 , 3.0 , 3.3	1.8 , 2.5 , 2.8 , 3.0 , 3.3			
Frequency Range		10.0 ~ 52.0 MHz	10.0 ~ 52.0 MHz	8.192 ~ 52.0 MHz	6.4 ~ 52.0 MHz			
Suggested package		M57S , VM57S	M572S , VM572S	M53S-AB , VM53S-AB	M57S-AB , VM57S-AB			
Package size		7.0 x 5.0 x 1.9 mm	7.0 x 5.0 x 2.3 mm	5.0 x 3.2 x 1.3 mm	7.0 x 5.0 x 1.4 mm			
Supply voltage (V_{DD}) [unit : V]		2.5 , 3.0 , 3.3	1.8 , 2.5 , 2.8 , 3.0 , 3.3	1.8 , 2.5 , 2.8 , 3.0 , 3.3	1.8 , 2.5 , 2.8 , 3.0 , 3.3			
Frequency Range		6.4 ~ 52.0 MHz	6.4 ~ 52.0 MHz	10.0 ~ 52.0 MHz	10.0 ~ 52.0 MHz			
Standard Frequency (Partial list) [MHz]		10.000	12.800	13.000	14.400	14.7456	15.360	16.367667
		16.384	19.200	19.440	20.000	25.000	26.000	27.000
Initial Calibration Tolerance		$< \pm 1$ ppm. at $+25^{\circ}\text{C} \pm 2^{\circ}\text{C}$						
Frequency Stability (ppm)		± 0.5 ppm	± 1.0 ppm	± 1.5 ppm	± 2.0 ppm	± 2.5 ppm	± 3.0 ppm	○ : available △ : contact us X : not available
Frequency Stability vs Temperature (examples)	0°C to 50°C	○	○	○	○	○	○	
	-10°C to 60°C	△	○	○	○	○	○	
	-20°C to 70°C	△	○	○	○	○	○	
	-30°C to 75°C	△	○	○	○	○	○	
	-30°C to 85°C	△	○	○	○	○	○	
	-40°C to 85°C	△	△	○	○	○	○	
Frequency Stability	vs Aging at $T_a = +25^{\circ}\text{C}$	± 1.0 ppm / year (max.)						
	vs Voltage Change	± 0.2 ppm (max.) , for a $\pm 5\%$ input voltage change .						
	vs Load Change	± 0.2 ppm (max.) , for a $\pm 10\%$ load condition change .						
	vs Reflow (SMD type)	± 1.0 ppm (max.) , 1 reflow and measured 24 hours afterwards .						
Output Voltage Level (peak to peak)		0.8 V p-p (min.)						
Current Consumption. (max.)		10.0 ~ 15 MHz: 1.5 mA ; 15.1 ~ 26.0 MHz : 2.0 mA ; 26.1 ~ 52.0 MHz : 3.5 mA						
Electrical Frequency Tuning (EFC) by external	Control Voltage Center	1.8 V	2.5 V	3.0 V / 3.3V				
		0.9 V \pm 0.6 V	1.4 V \pm 1.0 V	1.5 V \pm 1.0 V				
	Frequency Deviation Range	± 5.0 ppm (min.)						
	Slope Polarity (Transfer Function)	Positive slope. Positive voltage for positive frequency shift.						
Control Voltage		Input Impedance : 1.0M Ω (min.)	Modulation Bandwidth : 3 KHz (min.)	Linearity : $\pm 10\%$ (max.)				
Start-Up Time		2.0 msec. (typ.) , 5.0 msec. (max.) (reach 90% amplitude and at $+25^{\circ}\text{C} \pm 2^{\circ}\text{C}$)						
Output Load		10 K Ω // 10 pF $\pm 10\%$						
Output Format		DC block , AC coupled. EX : (V) M53 and (V) M32 model.						
Phase Noise [dBc / Hz ; (typ.)]	Offset	10 Hz	100 Hz	1 KHz	10 KHz	100 KHz		
	13.000 MHz	-80	-115	-135	-148	-148		
Storage Temperature		-40°C to $+85^{\circ}\text{C}$ or -55°C to $+125^{\circ}\text{C}$ (package dependent)						

TCXOs

Temperature Compensated Crystal Oscillators [TCXO " M " and VCTCXO " VM "]

Clipped Sine Wave Output Code " S " [SMD Type]

Outline Dimensions (Unit : mm) , Suggested pad Layout for SMDs

[M21S __] ; [VM21S __]	[M22S __] ; [VM22S __]
<p>Top View: 2.05±0.1, 1.65±0.1, MEC</p> <p>Bottom View: 1.2±0.1, 0.625, 0.4, 0.86, 0.4</p> <p>Land Pattern (reference): 0.6, 0.8, 1.2±0.1, 0.4</p> <p>Side View: 0.70±0.1</p> <p>Pad Connections : Pad 1 : Control voltage for VCTCXO ; Ground for TCXO . Pad 2 : Ground ; Pad 3 : Output ; Pad 4 : Supply Voltage</p>	<p>Top View: 2.5±0.2, 2.0±0.2, MEC</p> <p>Bottom View: 0.5, 1.9, 0.6, 1.3</p> <p>Land Pattern (reference): 0.6, 1.9, 1.3</p> <p>Side View: 0.8±0.1</p> <p>Pad Connections : Pad 1 : Control voltage for VCTCXO ; Ground for TCXO . Pad 2 : Ground ; Pad 3 : Output ; Pad 4 : Supply Voltage</p>
[M32S __] ; [VM32S __]	[M53S __] ; [VM53S __]
<p>Top View: 3.2±0.1, 2.5±0.1, MEC</p> <p>Bottom View: 0.6, 2.4, 0.7, 1.7</p> <p>Land Pattern (reference): 1.0, 2.6, 1.1, 1.9</p> <p>Side View: 1.2±0.1, 0.4 typ</p> <p>Pad Connections : Pad 1 : Control voltage for VCTCXO ; Ground for TCXO . Pad 2 : Ground ; Pad 3 : Output ; Pad 4 : Supply Voltage</p>	<p>Top View: 5.0±0.1, 3.2±0.1, MEC</p> <p>Bottom View: 1.1±0.1, 3.7, 0.7±0.1</p> <p>Land Pattern (reference): 1.4, 3.8, 1.1, 2.3</p> <p>Side View: 1.3±0.2</p> <p>Pad Connections : Pad 1 : Control voltage for VCTCXO ; Ground for TCXO . Pad 2 : Ground ; Pad 3 : Output ; Pad 4 : Supply Voltage</p>
[M57S __] ; [VM57S __]	[M572S __] ; [VM572S __]
<p>Top View: 7.0±0.2, 5.0±0.2, MEC</p> <p>Bottom View: 5.08±0.15, 1.40±0.15, 4.00±0.15, 0.80±0.15</p> <p>Land pattern(reference): 5.08, 1.50, 1.20, 4.20</p> <p>Side View: 1.9±0.2</p> <p>Pad Connections : Pad 1 : Control voltage for VCTCXO ; Ground for TCXO . Pad 2 : Ground ; Pad 3 : Output ; Pad 4 : Supply Voltage</p>	<p>Top View: 7.0±0.2, 5.0±0.2, MEC</p> <p>Bottom View: 1.4, 5.08, 1.2</p> <p>Land pattern(reference): 2.2, 5.08, 2.0, 1.8</p> <p>Side View: 2.3±0.1</p> <p>Pad Connections : Pad 1 : Control voltage for VCTCXO ; Ground for TCXO . Pad 2 : Ground ; Pad 3 : Output ; Pad 4 : Supply Voltage</p>

Outline Dimensions (Unit : mm) , Adapter Board Type

[M57S __ AB] ; [VM57S __ AB]	[M53S __ AB] ; [VM53S __ AB]
<p>Top View: 7.0±0.1, 5.0±0.1, MEC</p> <p>Bottom View: 1.4, 5.08, 1.0, 2.6</p> <p>Land pattern: 2.2, 5.08, 1.8</p> <p>Side View: 1.4±0.1, 0.7, 0.7</p> <p>Pad Connections : Pad 1 : Control voltage for VCTCXO ; No connection for TCXO Pad 2 : Ground ; Pad 3 : Output ; Pad 4 : Supply Voltage White marker is pad1 on PCB</p>	<p>Top View: 5.0±0.1, 3.2±0.1, MEC</p> <p>Bottom View: 1.0, 3.7, 0.7, 2.25</p> <p>Land Pattern: 1.4, 3.8, 1.1, 2.3</p> <p>Side View: 1.3±0.1, 0.6</p> <p>Pad Connections : Pad 1 : Control voltage for VCTCXO ; No connection for TCXO Pad 2 : Ground ; Pad 3 : Output ; Pad 4 : Supply Voltage White marker is pad1 on PCB</p>

Temperature Compensated Crystal Oscillators [TCXO " M " and VCTCXO " VM "]

Clipped Sine Wave ; Waveform Code " S " [Dip Type]

Features

- Frequency stability as tight as ± 0.5 ppm over -30°C to 85°C
- Frequency stability as tight as ± 1.0 ppm over -40°C to 85°C



General Specifications [$T_A = +25^{\circ}\text{C}$, $V_{DD} =$ at specified voltage , Load : 10K ohms//10 pF]

Output Waveform	Clipped Sine Wave . Waveform code is " S "				
Suggested package (Dip type)	M8S , VM8S	M9S , VM9S	M14S , VM14S	M15S , VM15S	M39S , VM39S
Model with Trimmer	-----	with Trimmer	-----	with Trimmer	with Trimmer
Package size (mm)	12.8 x 12.8 x 6.3	12.8 x 12.8 x 6.3	20.2 x 12.8 x 7.8	20.2 x 12.8 x 7.8	18.4 x 11.7 x 4.7
Supply voltage (V_{DD}) [unit : V]	1.8 , 2.5 , 3.0 , 3.3	1.8 , 2.5 , 3.0 , 3.3	1.8 , 2.5 , 3.0 , 3.3	1.8 , 2.5 , 3.0 , 3.3	1.8 , 2.5 , 3.0 , 3.3
Frequency Range	6.4 ~ 52.0 MHz	6.4 ~ 52.0 MHz	6.4 ~ 52.0 MHz	6.4 ~ 52.0 MHz	6.4 ~ 52.0 MHz

Standard Frequency (Partial list) [MHz]	10.000	12.800	13.000	14.400	14.7456	15.360	16.367667
	16.384	19.200	19.440	20.000	25.000	26.000	27.000
Initial Calibration Tolerance	$< \pm 1$ ppm. at $+25^{\circ}\text{C} \pm 2^{\circ}\text{C}$ for model with trimmer						
	$< \pm 2$ ppm. at $+25^{\circ}\text{C} \pm 2^{\circ}\text{C}$ for model without trimmer						
Frequency Stability (ppm)	± 0.5 ppm	± 1.0 ppm	± 1.5 ppm	± 2.0 ppm	± 2.5 ppm	± 3.0 ppm	○ : available △ : contact us X : not available
Frequency Stability vs Temperature (examples)	0°C to 50°C	○	○	○	○	○	
	-10°C to 60°C	△	○	○	○	○	
	-20°C to 70°C	△	○	○	○	○	
	-30°C to 75°C	△	○	○	○	○	
	-30°C to 85°C	△	○	○	○	○	
	-40°C to 85°C	△	△	○	○	○	
Frequency Stability	vs Aging at $T_a = +25^{\circ}\text{C}$	± 1.0 ppm / year (max.)					
	vs Voltage Change	± 0.2 ppm (max.) , for a $\pm 5\%$ input voltage change .					
	vs Load Change	± 0.2 ppm (max.) , for a $\pm 10\%$ load condition change .					
	vs Reflow (SMD type)	± 1.0 ppm (max.) , 1 reflow and measured 24 hours afterwards .					
Output Voltage Level (peak to peak)	0.8 V p-p (min.)						
Current Consumption. (max.)	10.0 ~ 15 MHz: 1.5 mA ; 15.1 ~ 26.0 MHz : 2.0 mA ; 26.1 ~ 52.0 MHz : 3.5 mA						

Electrical Frequency Tuning (EFC) by external Control Voltage	Control Voltage Center	1.8 V	2.5 V	3.0 V / 3.3V		
		$0.9\text{ V} \pm 0.6\text{ V}$	$1.4\text{ V} \pm 1.0\text{ V}$	$1.5\text{ V} \pm 1.0\text{ V}$		
	Frequency Deviation Range	± 5.0 ppm (min.)				
	Slope Polarity (Transfer Function)	Positive slope. Positive voltage for positive frequency shift.				
Control Voltage	Input Impedance : 1.0M Ω min.	Modulation Bandwidth : 3 KHz min.	Linearity : $\pm 10\%$ max.			
Start-Up Time.	2.0 msec. (typ.) , 5.0 msec. (max.) (reach 90% amplitude and at $+25^{\circ}\text{C} \pm 2^{\circ}\text{C}$)					
Output Load	10 K Ω // 10 pF $\pm 10\%$					
Phase Noise [dBc / Hz ; (typ.)]	Offset	10 Hz	100 Hz	1 KHz	10 KHz	100 KHz
	13.000 MHz	-80	-115	-135	-148	-148
Storage Temperature	-40°C to $+85^{\circ}\text{C}$ or -55°C to $+125^{\circ}\text{C}$ (package dependent)					

Temperature Compensated Crystal Oscillators [TCXO " M " and VCTCXO " VM "]

Clipped Sine Wave Output Code " S " [Dip Type]

Outline Dimensions (Unit : mm) , Suggested pin Layout for SMDs

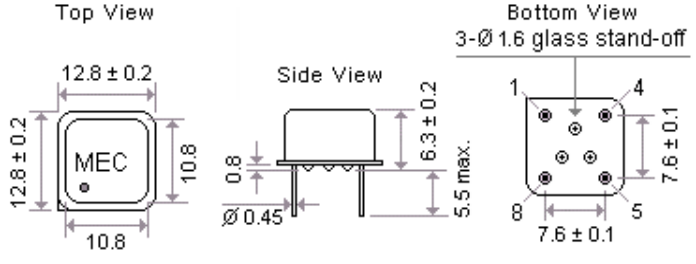
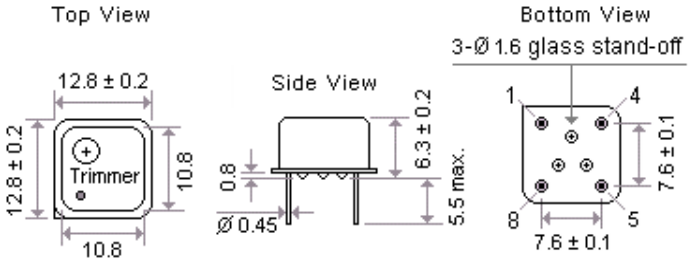
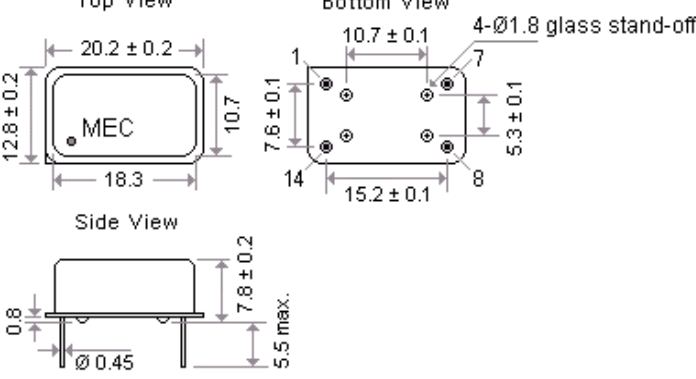
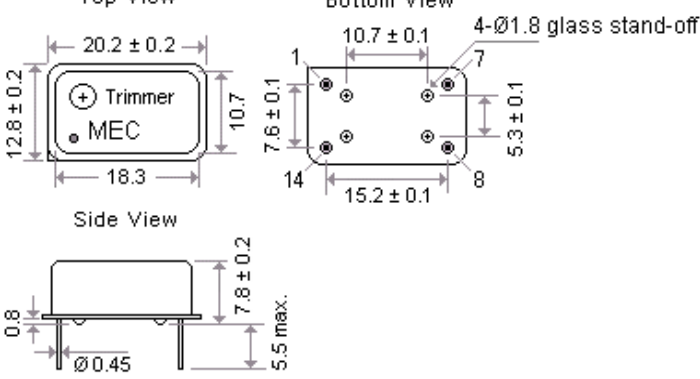
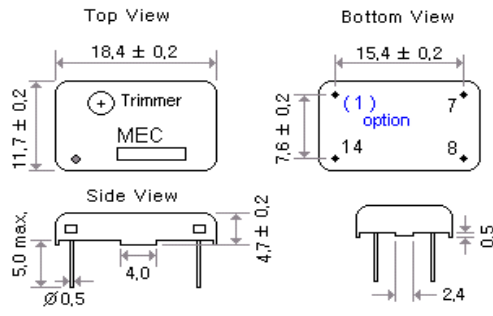
[M8S __] ; [VM8S __]	[M9S __] ; [VM9S __]
 <p>Pin Connections :</p> <p>Pin 1 : Control voltage for VCTCXO ; No connection for TCXO. Pin 4 : Ground ; Pin 5 : Output ; Pin 8 : Supply Voltage</p>	 <p>Pin Connections :</p> <p>Pin 1 : Control voltage for VCTCXO ; No connection for TCXO. Pin 4 : Ground ; Pin 5 : Output ; Pin 8 : Supply Voltage</p>
[M14S __] ; [VM14S __]	[M15S __] ; [VM15S __]
 <p>Pin Connections :</p> <p>Pin 1 : Control voltage for VCTCXO ; No connection for TCXO. Pin 7 : Ground ; Pin 8 : Output ; Pin 14 : Supply Voltage</p>	 <p>Pin Connections :</p> <p>Pin 1 : Control voltage for VCTCXO ; No connection for TCXO. Pin 7 : Ground ; Pin 8 : Output ; Pin 14 : Supply Voltage</p>
[M39S __] ; [VM39S __]	
 <p>Pin Connections :</p> <p>Pin 1 : Control voltage for VCTCXO [No physical pin 1 for TCXO. (3 pins only)] Pin 7 : Ground ; Pin 8 : Output ; Pin 14 : Supply Voltage</p>	

TCXOs

Temperature Compensated Crystal Oscillators [TCXO " M " and VCTCXO " VM "]

Clipped Sine Wave Output Code " S "

Part Number Format and Example

	[1]	[2]	[3]	-	[4]	-	[5]	/	[6]	-	[7]
	Holder Type	Output Wave	Supply Voltage		Center Frequency		Frequency Stability		Operating Temp. Range		Adapter Board
Examples	(1)	VM21	S	3	-	10.000	-	1.5	/	-20+70	
	(2)	M32	S	18	-	20.000	-	2.5	/	-30+75	
	(3)	VM57	S	33	-	10.000	-	1.0	/	-20+70	- AB
	(4)	M53	S	18	-	16.384	-	2.5	/	-40+85	- AB

Ex (1) : VM21S3 - 10.000 - 1.5 / -20+70 [VCTCXO , VM21 type , Clipped Sine Wave , 3.0V , 10.000MHz , ±1.5ppm from -20°C to 70°C]

Ex (2) : M32S18 - 20.000 - 2.5 / -30+75 [TCXO , M32 type , Clipped Sine Wave , 1.8V , 20.000MHz , ±2.5ppm from -30°C to 75°C]

Ex (3) : VM57S33 - 10.000 - 1.0 / -20+70 - AB [VCTCXO , VM57 type , Clipped Sine Wave , 3.3V , 10.000MHz , ±1.0ppm from -20°C to 70°C , Adapter Board]

Ex (4) : M53S18 - 16.384 - 2.5 / -40+85 - AB [TCXO , M53 type , Clipped Sine Wave , 1.8V , 16.384MHz , ±2.5ppm from -40°C to 85°C , Adapter Board]

[1]	Holder Type " M " stands for TCXO , " VM " stands for VCTCXO
[2]	" S " stands for Clipped Sine Wave
[3]	Supply voltage , " 18 " stands for +1.8V ; " 25 " stands for +2.5V ; " 28 " stands for +2.8V ; " 3 " stands for +3.0V ; " 33 " stands for +3.3V
[4]	Center Frequency in MHz
[5]	Frequency stability in ±_ ppm ; ex 1 : ± 1.5ppm --- 1.5 , ex 2 : ± 2.5ppm --- 2.5 , ex 3 : ± 1.0ppm --- 1.0 , ex 4 : ± 2.5ppm --- 2.5
[6]	Operating temperature range in °C ex 1 : -20 °C to 70°C ----- -20+70 ; ex 2 : -30 °C to 75°C ----- -30+75 ; ex 3 : -20 °C to 70°C ----- -20+70 ; ex 4 : -40 °C to 85°C ----- -40+85
[7]	Adapter Board Type ----- AB

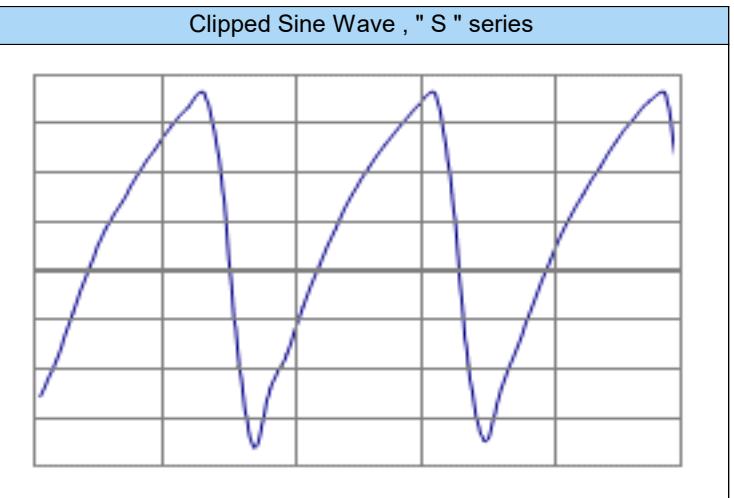
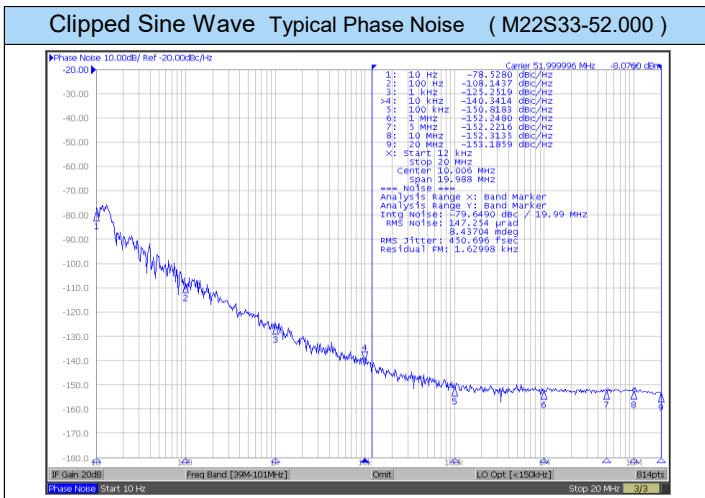

Test Circuits

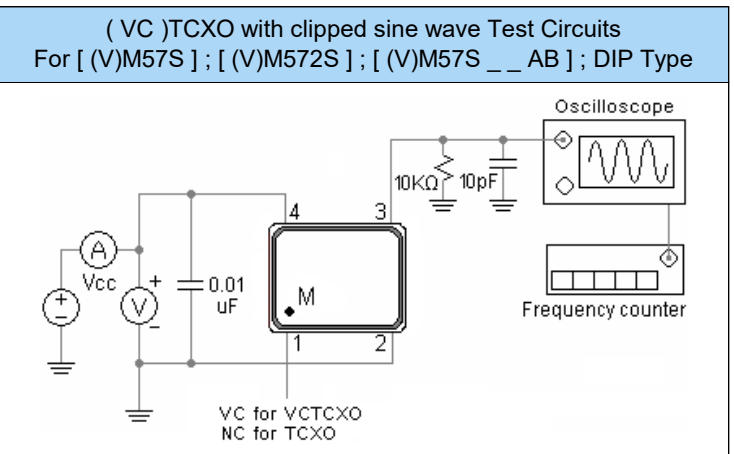
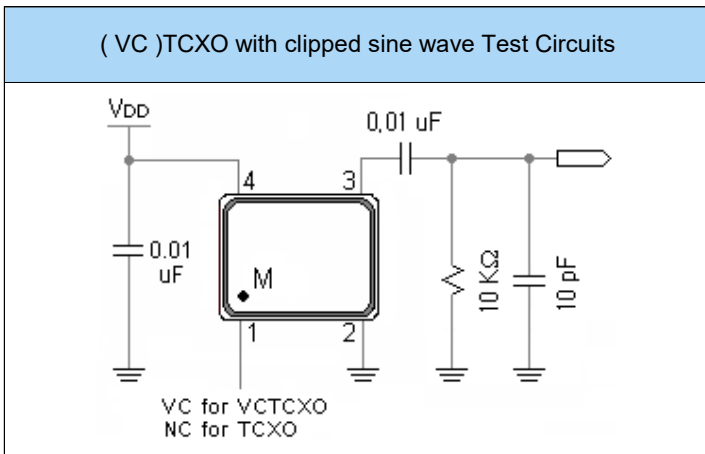

Temperature Compensated Crystal Oscillators [TCXO " M " and VCTCXO " VM "]

Output Waveform : CMOS " T " , LVPECL " P " , LVDS " D " , HCSL " C " , CML " Q "

Product Summary :

Product Selection Guide

CMOS output waveform , " T " series

TCXO	VCTCXO	Available Freq. Range	RoHS Compliant Equivalent Model	Package Description	
● Leadless Surface Mount Types					
M211T_	-----	10 ~ 52 MHz	Same	4 pad ceramic substrate . (2.05 x 1.65 x 0.70 mm)	
M221T_	-----	9.5 ~ 60 MHz	Same	4 pad ceramic substrate . (2.5 x 2.0 x 0.8 mm)	
M32T_	VM32T_	8.192 ~ 40 MHz	Same	4 pad ceramic substrate . (3.2 x 2.5 x 1.0 mm)	
M321T_	-----	9.5 ~ 60 MHz	Same	4 pad ceramic substrate . (3.2 x 2.5 x 1.2 mm)	
M531T_AB	-----	9.5 ~ 60 MHz	Same	4 pad FR4 substrate . (5.0 x 3.2 x 1.3 mm)	
MTF326T_	VMTF326T_	1 ~ 200 MHz	Same	6 pad ceramic substrate . (3.2 x 2.5 x 1.6 mm)	
M53T_	VM53T_	6.4 ~ 40 MHz	Same	4 pad ceramic substrate . (5.0 x 3.2 x 1.3 mm)	
MTF538T_	VMTF538T_	1 ~ 200 MHz	Same	8 pad ceramic substrate . (5.0 x 3.2 x 1.4 mm)	
M571T_AB	-----	9.5 ~ 60 MHz	Same	4 pad FR4 substrate . (7.0 x 5.0 x 1.4 mm)	
M572T_	VM572T_	32.768 KHz , 1.25 ~ 52 MHz	Same	4 pad ceramic substrate . (7.0 x 5.0 x 2.3 mm)	
ME21T_	-----	32.768 KHz	Same	4 pad ceramic substrate . (2.1 x 1.3 x 1.1 mm)	
ME32T_	-----	32.768 KHz	Same	4 pad ceramic substrate . (3.2 x 2.5 x 1.4 mm)	
MQN326T_	VMQN326T_	10 ~ 250 MHz	Same	6 pad ceramic substrate . (3.2 x 2.5 x 1.6 mm)	
MQN574T_	VMQN574T_			4 pad ceramic substrate . (7.0 x 5.0 x 2.5 mm)	
MQF326T_	VMQF326T_	10 ~ 250 MHz	Same	6 pad ceramic substrate . (3.2 x 2.5 x 1.6 mm)	
MQF574T_	VMQF574T_			4 pad ceramic substrate . (7.0 x 5.0 x 2.5 mm)	
● Thru - Hold Types					
M39T_	VM39T_	6.4 ~ 52.0 MHz	M39T_	VM39T_	3 pin if TCXO. Package height = 4.7 mm
M14T_	VM14T_		M14T_	VM14T_	4 pin if TCXO. Package height = 7.8 mm
M15T_	VM15T_		M15T_	VM15T_	Dip Type (4 pins) , With Trimmer
M8T_	VM8T_		M8T_	VM8T_	Dip Type (4 pins) , Half size , Hermetically Sealed
M9T_	VM9T_		M9T_	VM9T_	Dip Type (4 pins) , With Trimmer

Differential output waveform , LVPECL " P " series , LVDS " D " series , HCSL " C " series , CML " Q " series

● Leadless Surface Mount Types				
MQN326P_	VMQN326P_	10 ~ 1,500 MHz	Same	6 pad ceramic substrate . (3.2 x 2.5 x 1.6 mm)
MQN576P_	VMQN576P_			6 pad ceramic substrate . (7.0 x 5.0 x 2.5 mm)
MQF326P_	VMQF326P_	10 ~ 1500 MHz	Same	6 pad ceramic substrate . (3.2 x 2.5 x 1.6 mm)
MQF576P_	VMQF576P_			6 pad ceramic substrate . (7.0 x 5.0 x 2.5 mm)
MJF326P_	VMJF326P_	15 ~ 2,100 MHz	Same	6 pad ceramic substrate . (3.2 x 2.5 x 1.6 mm)
MJF538P_	VMJF538P_	15 ~ 2,100 MHz	Same	8 pad ceramic substrate . (5.0 x 3.2 x 1.4 mm)
MQN326D_	VMQN326D_	10 ~ 1,500 MHz	Same	6 pad ceramic substrate . (3.2 x 2.5 x 1.6 mm)
MQN576D_	VMQN576D_			6 pad ceramic substrate . (7.0 x 5.0 x 2.5 mm)
MQF326D_	VMQF326D_	10 ~ 1500 MHz	Same	6 pad ceramic substrate . (3.2 x 2.5 x 1.6 mm)
MQF576D_	VMQF576D_			6 pad ceramic substrate . (7.0 x 5.0 x 2.5 mm)
MJF326D_	VMJF326D_	15 ~ 2,100 MHz	Same	6 pad ceramic substrate . (3.2 x 2.5 x 1.6 mm)
MJF538D_	VMJF538D_	15 ~ 2,100 MHz	Same	8 pad ceramic substrate . (5.0 x 3.2 x 1.4 mm)
MJF326C_	VMJF326C_	15 ~ 700 MHz	Same	6 pad ceramic substrate . (3.2 x 2.5 x 1.6 mm)
MJF538C_	VMJF538C_	15 ~ 700 MHz	Same	8 pad ceramic substrate . (5.0 x 3.2 x 1.4 mm)
MJF326Q_	VMJF326Q_	15 ~ 2,100 MHz	Same	6 pad ceramic substrate . (3.2 x 2.5 x 1.6 mm)
MJF538Q_	VMJF538Q_	15 ~ 2,100 MHz	Same	8 pad ceramic substrate . (5.0 x 3.2 x 1.4 mm)

" _ " is voltage code. Please see the table in next page.

Note: Frequency tuning by built-in mechanical trimmer is standard for all models except for (V)M572T,(V)M572P,(V)M572D .

Note: Non-hermetically sealed (VC)TCXO products are not subject to the washing cycles as the solvent will degrade the trimmer capacitor .

If cleaning is mandatory please choose hermetically sealed packages or no-trimmer option.

Temperature Compensated Crystal Oscillators [TCXO " M " and VCTCXO " VM "]

CMOS Output

TCXO	VCTCXO	KHz range	CMOS	SMD	15pF	3.3V	32.768 KHz
M _ T	VM _ T						

Features

- Wide frequency range : [32.768 KHz]
- Frequency stability as tight as ± 0.5 ppm over 0°C to 50°C
- Frequency stability as tight as ± 1.0 ppm over -40°C to 85°C



General specifications of all available packages , at Ta=+25°C , CL=15pF

Output Waveform		Square Wave [CMOS] . Waveform Wode is " T "						
Suggested Package (Size)	Type	SMD						
	Dimensions	(V)M572T (7.0 x 5.0 x 2.3 mm)						
Frequency Range		32.768 KHz [From KHz with divider. mA current consumption.]						
Supply Voltage V _{DD} (code)		+3.3 V \pm 5% (voltage code is " 33 ")						
Output Logic Levels	Logic High " 1 "	2.97 V _{DD} (min.)						○ : available △ : contact us X : not available
	Logic Low " 0 "	0.33 V _{DD} (max.)						
Current Consumption. (max.) (Over operating temperature range .)		8.0 mA (max.) for 32.768 KHz at +3.3V						
Initial Calibration Tolerance		± 2.0 ppm at +25°C ± 2 °C.						
Frequency Stability (ppm)		± 0.5 ppm	± 1.0 ppm	± 1.5 ppm	± 2.0 ppm	± 2.5 ppm	± 3.0 ppm	
Frequency Stability vs Temperature (examples)	0°C to 50°C	○	○	○	○	○	○	
	-10°C to 60°C	△	○	○	○	○	○	
	-20°C to 70°C	X	○	○	○	○	○	
	-30°C to 75°C	X	○	○	○	○	○	
	-30°C to 85°C	X	○	○	○	○	○	
	-40°C to 85°C	X	△	○	○	○	○	
Frequency Stability	vs Aging at Ta = +25°C	± 1.0 ppm / year (max.)						
	vs Voltage Change	± 0.3 ppm (max.) , for a $\pm 5\%$ input voltage change .						
	vs Load Change	± 0.3 ppm (max.) , for a $\pm 10\%$ load condition change .						
	vs Reflow (SMD type)	± 1.0 ppm (max.) , 1 reflow and measured 24 hours afterwards .						
Rise and Fall Time	10.0 nsec. (max.) Measured at 20% \leftrightarrow 80% of the waveform							
Electrical Frequency Tuning (EFC) by external Control Voltage	Control Voltage Center	1.5 V \pm 1.0 V (3.3V)						
	Frequency Deviation Range	± 5.0 ppm (min.)						
	Slope Polarity (Transfer Function	Positive slope. Positive voltage for positive frequency shift.						
		Input Impedance : 1.0M Ω (min.)	Modulation Bandwidth : 3 KHz (min.)			Linearity : $\pm 10\%$ (max.)		
Start-Up Time.	5.0 msec. (typ.) , 10.0 msec. (max.) (reach 90% amplitude and at +25°C ± 2 °C)							
Duty Cycle	50 % \pm 5%							
Output Load	15 pF							
Storage Temperature	-40°C to +85°C or -55°C to +125°C (package dependent)							

TCXOs

Temperature Compensated Crystal Oscillators [TCXO " M " and VCTCXO " VM "]

CMOS Wave Output Code " T "

Part Number Format and Example

[1]	[2]	[3]		[4]		[5]		[6]
Holder Type	Output Wave	Supply Voltage	-	Center Frequency	-	Frequency Stability	/	Operating Temp. Range

Examples	M572	T	33	-	32.768K	-	1.5	/	-30+85
----------	------	---	----	---	---------	---	-----	---	--------

Ex : M572T33 - 32.768K - 1.5 / -30+85 [TCXO , M572 type , CMOS output , 3.3V , 32.768KHz , ±1.5ppm from -30°C to 85°C]

[1]	Holder Type " M " stands for TCXO , " VM " stands for VCTCXO
[2]	" T " stands for Square Wave ex : M572T --- TCXO , M572 package , CMOS output
[3]	Supply voltage , " 33 " stands for +3.3V
[4]	Center Frequency in KHz
[5]	Frequency stability in ± _ ppm ; ex : ± 1.5ppm --- 1.5
[6]	Operating temperature range in °C ex : -30 °C to 85°C ----- -30+85

Outline Dimensions (Unit : mm) , Suggested pad Layout for SMDs

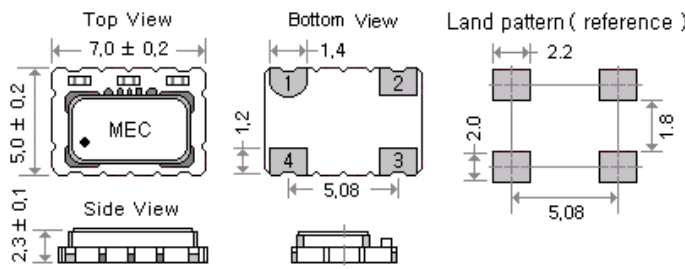
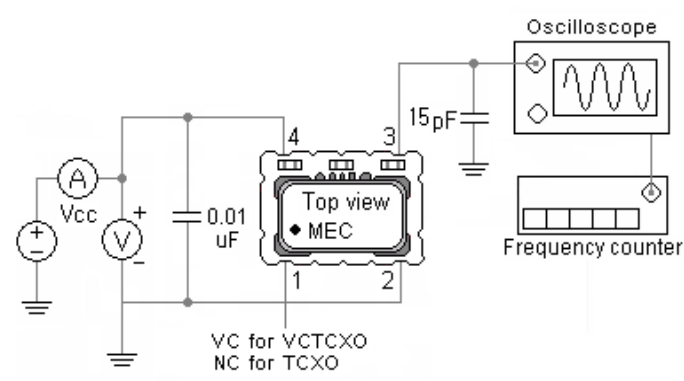
[(V) M572T_ _]	(VC)TCXO with CMOS output wave test Circuit
 <p>Top View: 7.0 ± 0.2 mm width, 5.0 ± 0.2 mm height, MEC label.</p> <p>Bottom View: 1.4 mm width, 5.08 mm length, pads 1, 2, 3, 4.</p> <p>Side View: 2.3 ± 0.1 mm height.</p> <p>Land pattern (reference): 2.2 mm width, 2.0 mm height, 5.08 mm length, 1.8 mm spacing.</p> <p>Pad Connections : Pad 1 : NC --- TCXO ; Vcon --- VCTCXO Pad 2 : Ground ; Pad 3 : Output , Pad 4 : Supply Voltage</p>	 <p>VC for VCTCXO NC for TCXO</p>

Temperature Compensated Crystal Oscillators [TCXO " M " and VCTCXO " VM "] CMOS Output

TCXO	VCTCXO	MHz range	CMOS	SMD	15pF	1.8 V 3.0 V	2.5 V 3.3 V	Min. 6.4 MHz	Max. 52.0 MHz
------	--------	-----------	------	-----	------	----------------	----------------	-----------------	------------------

Features

- Wide frequency range : [6.4 MHz ~ 52.0 MHz]
- Frequency stability as tight as ± 0.5 ppm over 0°C to 50°C
- Frequency stability as tight as ± 1.0 ppm over -40°C to 85°C



General specifications of all available packages , at $T_a=+25^{\circ}\text{C}$, $CL=15\text{pF}$

Output Waveform		Square wave [CMOS] . Waveform code is " T "						
Type	M32T , VM32T		M53T , VM53T		M572T , VM572T			
Package size (mm)	3.2 x 2.5 x 1.0		5.0 x 3.2 x 1.3		7.0 x 5.0 x 2.3			
Frequency Range	8.192 ~ 40.0 MHz		6.4 ~ 40.0 MHz		6.4 ~ 52.0 MHz			
Supply Voltage V_{DD} (code)			+1.8 V \pm 5% (code is " 18 ")	+2.5 V \pm 5% (code is " 25 ")	+3.0 V \pm 5% (code is " 3 ")	+3.3 V \pm 5% (code is " 33 ")		
Current Consumption. (max.) (Over operating temperature range .)		Package	M32T	M53T	M572T			
			6 mA	6 mA	6 mA	6 mA		
			6 mA	6 mA	6 mA	6 mA		
			10 mA	10 mA	13 mA	13 mA		
Output Logic Levels		Logic High " 1 " (min.)	1.62 V	2.25 V	2.7 V	2.97 V		
		Logic Low " 0 " (max.)	0.25 V	0.25 V	0.3 V	0.33 V		
Standard Frequency (Partial list) [MHz]			10.000	12.800	13.000	14.7456	16.000	16.384
			19.200	19.440	19.680	20.000	25.000	27.000
Initial Calibration Tolerance			Models with mechanical trimmer : $< \pm 1.0$ ppm. $+25^{\circ}\text{C} \pm 2^{\circ}\text{C}$.					
			Models without mechanical trimmer : $< \pm 2.0$ ppm at $+25^{\circ}\text{C} \pm 2^{\circ}\text{C}$.					
Frequency Stability (ppm)			± 0.5 ppm	± 1.0 ppm	± 1.5 ppm	± 2.0 ppm	± 2.5 ppm	± 3.0 ppm
Frequency Stability vs Temperature (examples)		0°C to 50°C	○	○	○	○	○	○
		-10°C to 60°C	△	○	○	○	○	○
		-20°C to 70°C	X	○	○	○	○	○
		-30°C to 75°C	X	○	○	○	○	○
		-30°C to 85°C	X	○	○	○	○	○
		-40°C to 85°C	X	△	△	△	○	○
Frequency Stability		vs Aging at $T_a = +25^{\circ}\text{C}$	± 1.0 ppm / year (max.)					
		vs Voltage Change	± 0.3 ppm (max.) , for a $\pm 5\%$ input voltage change .					
		vs Load Change	± 0.3 ppm (max.) , for a $\pm 10\%$ load condition change .					
		vs Reflow (SMD type)	± 1.0 ppm (max.) , 1 reflow and measured 24 hours afterwards .					
Electrical Frequency		Control Voltage Center	0.9 V \pm 0.6 V (1.8 V) ; 1.4 V \pm 1.0 V (2.5V) ; 1.5 V \pm 1.0 V (3.0V / 3.3V)					
Tuning (EFC) by external		Frequency Deviation Range	± 5.0 ppm (min.)					
		Slope Polarity (Transfer Function)	Positive slope. Positive voltage for positive frequency shift.					
Control Voltage		Input Impedance : 1.0M Ω (min.)	Modulation Bandwidth : 20 KHz (min.)			Linearity : $\pm 10\%$ (max.)		
Output Load		15 pF						
Duty Cycle		Standard: 50 % \pm 10 % ; Option: 50 % \pm 5 %						
Storage Temperature		-40°C to $+85^{\circ}\text{C}$ or -55°C to $+125^{\circ}\text{C}$ (package dependent)						
Phase Noise [dBc / Hz (typ.)]		Offset	10 Hz	100 Hz	1 KHz	10 KHz	100 KHz	
		M572T33 - 10.000	-96 dBc / Hz	-122 dBc / Hz	-138 dBc / Hz	-145 dBc / Hz	-150 dBc / Hz	

TCXOs

Temperature Compensated Crystal Oscillators [TCXO " M " and VCTCXO " VM "]

CMOS Wave Output Code " T "

Outline Dimensions (Unit : mm) , Suggested pad Layout for SMDs

[(V) M32T__]			[(V) M53T__]		
<p>Top View</p>	<p>Bottom View</p>	<p>Land Pattern (reference)</p>	<p>Top View</p>	<p>Bottom View</p>	<p>Land Pattern (reference)</p>
<p>Side View</p>			<p>Side View</p>		
<p>Pad Connections :</p> <p>Pad 1 : Control voltage for VCTCXO ; Ground for TCXO .</p> <p>Pad 2 : Ground ; Pin 3 : Output , Pin 4 : Supply Voltage</p>			<p>Pad Connections :</p> <p>Pad 1 : Control voltage for VCTCXO ; Ground for TCXO .</p> <p>Pad 2 : Ground ; Pad 3 : Output , Pad 4 : Supply Voltage</p>		
[(V) M572T__]					
<p>Top View</p>	<p>Bottom View</p>	<p>Land pattern (reference)</p>			
<p>Side View</p>					
<p>Pad Connections :</p> <p>Pad 1 : NC --- TCXO ; Vcon --- VCTCXO</p> <p>Pad 2 : Ground ; Pad 3 : Output , Pad 4 : Supply Voltage</p>					

Temperature Compensated Crystal Oscillators [TCXO " M " and VCTCXO " VM "]

CMOS Output

TCXO	VCTCXO	MHz range	CMOS	DIP	15pF	1.8 V	2.5 V	Min.	Max.
M _ T	VM _ T					3.0 V	3.3 V	6.4 MHz	52.0 MHz

Features

- Wide frequency range : [6.4 ~ 52.0 MHz]
- Frequency stability as tight as ± 0.5 ppm over 0°C to 50°C
- Frequency stability as tight as ± 1.0 ppm over -40°C to 85°C

General specifications of all available packages , at Ta=+25°C , CL=15pF



Output Waveform	Square wave [CMOS] . Waveform code is " T "				
Suggested package (Dip type)	M8T , VM8T	M9T , VM9T	M14T , VM14T	M15T , VM15T	M39T , VM39T
Model with Trimmer	-----	with Trimmer	-----	with Trimmer	with Trimmer
Package size (mm)	12.8 x 12.8 x 6.3	12.8 x 12.8 x 6.3	20.2 x 12.8 x 7.8	20.2 x 12.8 x 7.8	18.4 x 11.7 x 4.7
Supply voltage (V _{DD}) [unit : V]	1.8 , 2.5 , 3.0 , 3.3	1.8 , 2.5 , 3.0 , 3.3	1.8 , 2.5 , 3.0 , 3.3	1.8 , 2.5 , 3.0 , 3.3	1.8 , 2.5 , 3.0 , 3.3
Frequency Range	6.4 ~ 52.0 MHz	6.4 ~ 52.0 MHz	6.4 ~ 52.0 MHz	6.4 ~ 52.0 MHz	6.4 ~ 52.0 MHz

Supply Voltage V _{DD} (code)		+1.8 V \pm 5% (code is " 18 ")	+2.5 V \pm 5% (code is " 25 ")	+3.0 V \pm 5% (code is " 3 ")	+3.3 V \pm 5% (code is " 33 ")	
Current Consumption. (max.) (Over operating temperature range .)	Package	M8T	5 mA	7 mA	-----	10 mA
		M9T	6 mA	6 mA	6 mA	6 mA
		M14T	10 mA	10 mA	13 mA	13 mA
		M15T	10 mA	10 mA	13 mA	13 mA
		M39T	-----	10 mA	13 mA	13 mA
Output Logic Levels	Logic High " 1 " (min.)	1.62 V	2.25 V	2.7 V	2.97 V	
	Logic Low " 0 " (max.)	0.25 V	0.25 V	0.3 V	0.33 V	

Standard Frequency (Partial list) [MHz]	10.000	12.800	13.000	14.7456	16.000	16.384
	19.200	19.440	19.680	20.000	25.000	27.000

Initial Calibration Tolerance	Models with mechanical trimmer : $< \pm 1.0$ ppm. +25°C \pm 2°C. Models without mechanical trimmer : $< \pm 2.0$ ppm at +25°C \pm 2°C.					
-------------------------------	---	--	--	--	--	--

Frequency Stability (ppm)	± 0.5 ppm ± 1.0 ppm ± 1.5 ppm ± 2.0 ppm ± 2.5 ppm ± 3.0 ppm						○ : available △ : contact us X : not available
	Frequency Stability vs Temperature (examples)	0°C to 50°C	○	○	○	○	
	-10°C to 60°C	△	○	○	○	○	○
	-20°C to 70°C	X	○	○	○	○	○
	-30°C to 75°C	X	○	○	○	○	○
	-30°C to 85°C	X	○	○	○	○	○
	-40°C to 85°C	X	△	△	△	○	○

Frequency Stability	vs Aging at Ta = +25°C	± 1.0 ppm / year (max.)					
	vs Voltage Change	± 0.3 ppm (max.) , for a $\pm 5\%$ input voltage change .					
	vs Load Change	± 0.3 ppm (max.) , for a $\pm 10\%$ load condition change .					
	vs Reflow (SMD type)	± 1.0 ppm (max.) , 1 reflow and measured 24 hours afterwards .					

Electrical Frequency Tuning (EFC) by external Control Voltage	Control Voltage Center	0.9 V \pm 0.6 V (1.8 V) ; 1.4 V \pm 1.0 V (2.5 V) ; 1.5 V \pm 1.0 V (3.0V / 3.3V)					
	Frequency Deviation Range	± 5.0 ppm (min.)					
	Slope Polarity (Transfer Function)	Positive slope. Positive voltage for positive frequency shift.					
		Input Impedance : 1.0M Ω (min.)	Modulation Bandwidth : 20 KHz (min.)		Linearity : $\pm 10\%$ (max.)		

Output Load	15 pF					
Rise and Fall Time	10.0 nsec. (max.) Measured at 20% \leftrightarrow 80% of the waveform					
Start-Up Time.	5.0 msec. (typ.) , 10.0 msec. (max.) (reach 90% amplitude and at+25°C \pm 2°C)					
Duty Cycle	Standard: 50 % \pm 10 % ; Option: 50 % \pm 5 %					
Storage Temperature	-40°C to +85°C or -55°C to +125°C (package dependent)					
Phase Noise [dBc / Hz (typ.)]	Offset	10 Hz	100 Hz	1 KHz	10 KHz	100 KHz
	M572T33 - 10.000	-96 dBc / Hz	-122 dBc / Hz	-138 dBc / Hz	-145 dBc / Hz	-150 dBc / Hz

Temperature Compensated Crystal Oscillators [TCXO " M " and VCTCXO " VM "]

CMOS Wave Output Code " T "

Outline Dimensions (Unit : mm) , Suggested pin Layout

[(V) M_8T__] --- Gull - wing SMD is also available .

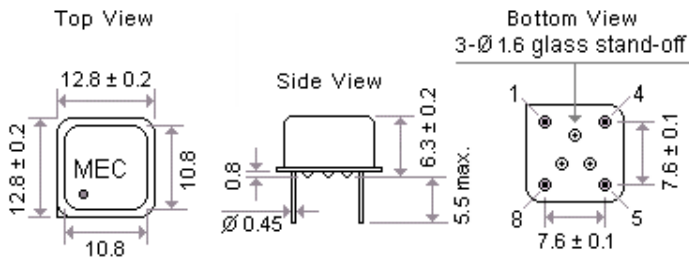

Pad Connections :

Pin 1 : Control voltage for VCTCXO ; No connection for TCXO.

Pin 4 : Ground ; Pin 5 : Output ; Pin 8 : Supply Voltage

[(V) M_9T__] --- with mechanical trimmer

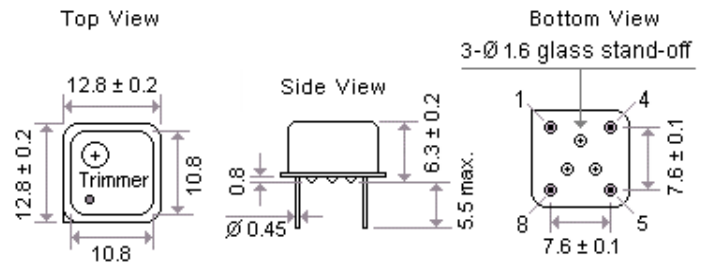

Pad Connections :

Pin 1 : Control voltage for VCTCXO ; No connection for TCXO.

Pin 4 : Ground ; Pin 5 : Output ; Pin 8 : Supply Voltage

[(V) M_14T__] --- Gull - wing SMD is also available .

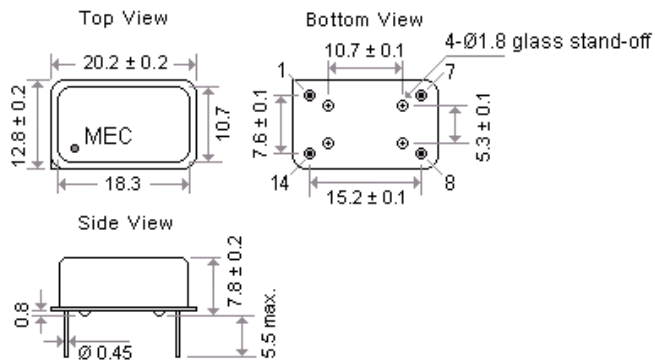

Pad Connections :

Pin 1 : Control voltage for VCTCXO ; No connection for TCXO.

Pin 7 : Ground ; Pin 8 : Output ; Pin 14 : Supply Voltage

[(V) M_15T__] --- with mechanical trimmer

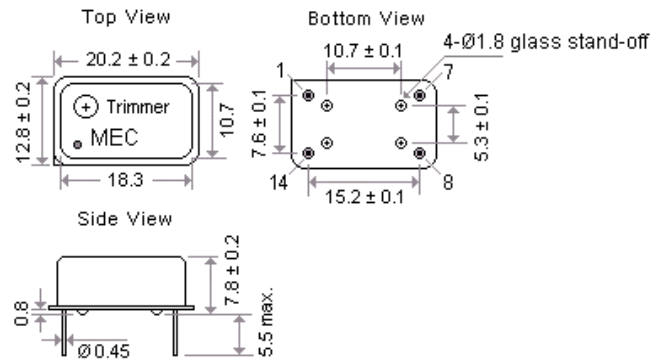

Pad Connections :

Pin 1 : Control voltage for VCTCXO ; No connection for TCXO.

Pin 7 : Ground ; Pin 8 : Output ; Pin 14 : Supply Voltage

[(V) M_39T__]

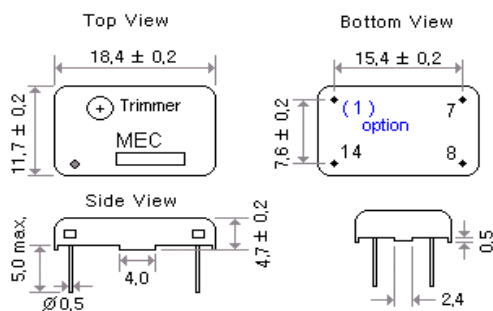

Pad Connections :

Pin 1 : Control voltage for VCTCXO

[No physical pin 1 for TCXO. (3 pins only)]

Pin 7 : Ground ; Pin 8 : Output ; Pin 14 : Supply Voltage

Temperature Compensated Crystal Oscillators [TCXO " M " and VCTCXO " VM "]

CMOS Wave Output Code " T "

Part Number Format and Example

	[1]	[2]	[3]	-	[4]	-	[5]	/	[6]
	Holder Type	Output Wave	Supply Voltage		Center Frequency		Frequency Stability		Operating Temp. Range
Examples	(1)	VM32	T	3	10.000	1.5	-20+70		
	(2)	M572	T	3	20.000	2.5	-30+85		

Ex (1) : VM32T3 - 10.000 - 1.5 / -20+70 [VCTCXO , VM32 type , CMOS output , 3.0V , 10.000MHz , ±1.5ppm from -20°C to 70°C]

Ex (2) : M572T3 - 20.000 - 2.5 / -30+85 [TCXO , M572 type , CMOS output , 3.0V , 20.000MHz , ±2.5ppm from -30°C to 85°C]

[1]	Holder Type " M " stands for TCXO , " VM " stands for VCTCXO
[2]	" T " stands for Square Wave ex 1 : VM32T --- VCTCXO , VM32 package , CMOS Output ; ex 2 : M572T --- TCXO , M572 package , CMOS Output
[3]	Supply voltage , " 18 " stands for +1.8V ; " 25 " stands for +2.5V ; " 3 " stands for +3.0V ; " 33 " stands for +3.3V
[4]	Center Frequency in MHz
[5]	Frequency stability in ±_ ppm ; ex 1 : ± 1.5ppm --- 1.5 , ex 2 : ± 2.5ppm --- 2.5
[6]	Operating temperature range in °C ex 1 : -20 °C to 70°C ----- -20+70 ; ex 2 : -30 °C to 85°C ----- -30+85

CMOS Typical Phase Noise (M572T33-20.000)

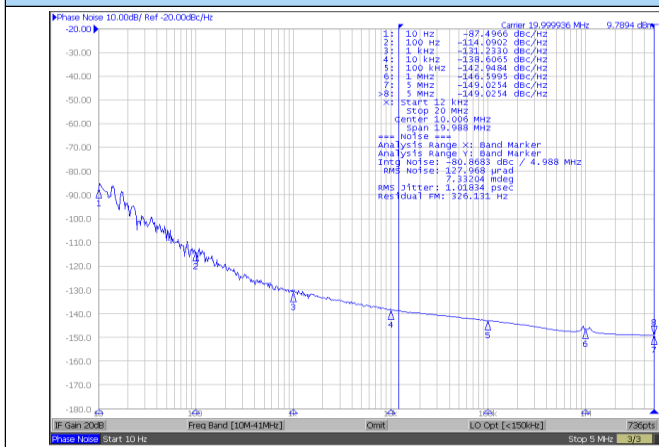

CMOS Output Wave , " T " series

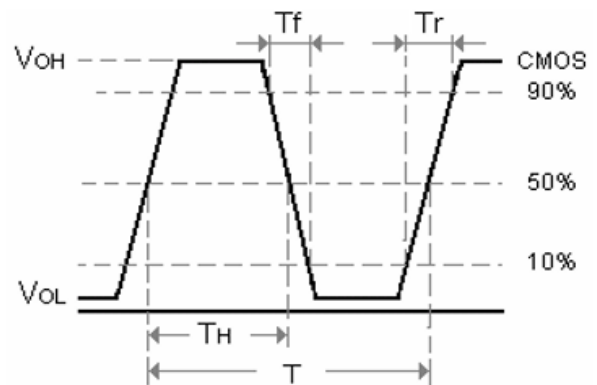

(VC)TCXO with CMOS square wave: Ex. VM14T33

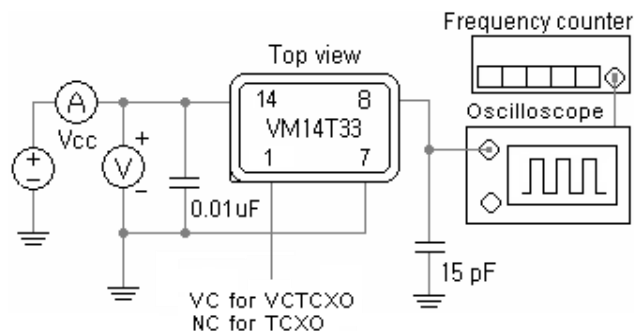

Temperature Compensated Crystal Oscillators [TCXO " M "]

CMOS Output

TCXO	uA Current	± 8 ppm	CMOS	SMD	15 pF	1.8V	2.5V
ME _ T	32.768 KHz	-40 to +105 °C				3.0V	3.3V

Features

- CMOS 32.768 KHz TCXO with a maximum frequency stability of ± 5 ppm (± 2.62 minutes / year) over -40 to +85°C, providing a much better timekeeping accuracy than the competition
- A proprietary temp. compensation technique is applied to the built-in 32.768 KHz tuning fork crystal & temp. sensor
- A 1.5 uA typical current consumption makes it ideal for battery-operated devices
- Small ceramic SMD package, ideal for new miniaturizing applications

Applications:

- Frequency reference for real time clocks (RTCs)
- Smart metering, data loggers
- Portable instruments
- GPS receivers. Telematics.
- Timing synchronization for networks, servers, hubs, routers and switches

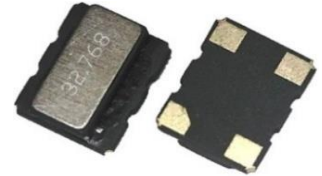

General specifications of all available packages , at Ta=+25°C , CL=15pF

Output Waveform		Square wave [CMOS] , Waveform code is " T "	
Model		ME21T	ME32T
Package size		2.1 x 1.3 x 1.0 mm	3.2 x 2.5 x 1.3 mm
Standard Supply Voltages		1.8V , 2.5V , 3.0V , 3.3V	
Start-up Time		1.0 sec (max.)	
Nominal Frequency		32.768 KHz	
Initial Calibration Tolerance (at +25°C ± 3°C)		± 2.5 ppm (max.)	
Current Consumption (With No Load)		1.0 uA (typ.) , 2.0 uA (max.)	
Frequency Stability over Temperature (max.)		± 5.0 ppm (-40°C to +85°C) ± 8.0 ppm (-40°C to +105°C)	
Timing error over time [± 5 ppm (-40°C to +85°C)]		± 0.432 sec/day ; ± 12.960 sec / month ; ± 2.628 minutes / year , w.r.t fo at +25°C.	
Frequency Stability	vs Aging	± 3.0 ppm / year (max.) first year at +25°C	
	vs Load Change	± 0.2 ppm (max.) for a ± 10% loading condition change	
	vs Supply Voltage Delta Freq / V	± 1.0 ppm / V (max.)	
Output Load		15 pF	
Output Voltage Level	V _{OH}	90% V _{DD} (min.)	
	V _{OL}	10% V _{DD} (max.)	
Rise Time and Fall Time		100 ns (max.) Measured at 20% ↔ 80% of the waveform	
Duty Cycle		50% ± 10%	
Output Enable / Disable Function (Open connection is prohibited)		V _{DD} of 80% (min.) to enable output	
		V _{DD} of 20% (max.) to disable output	

TCXOs

Part Number Format and Example

[1]	[2]	[3]		[4]		[5]		[6]
Holder Type	Waveform Code	Supply Voltage	-	Nominal Frequency	-	Frequency Stability	/	Operating Temp. Range

Examples	(1)	ME32	T	33	-	32.768 K	-	8.0	/	-40+105
	(2)	ME21	T	18	-	32.768 K	-	5.0	/	-40+85

Ex (1): **ME32T33 - 32.768K - 8.0 / -40+105** [ME series 3225 type , CMOS , 3.3V , 32.768 KHz , ± 8.0 ppm from -40°C to +105°C]
 Ex (2): **ME21T18 - 32.768K - 5.0 / -40+85** [ME series 2113 type , CMOS , 1.8V , 32.768 KHz , ± 5.0 ppm from -40°C to +85°C]

[1]	Holder Type "ME32" stands for TCXO 3225 type ; "ME21" stands for TCXO 2113 type
[2]	"T" stands for CMOS waveform
[3]	Supply voltage , "18" stands for +1.8V ; "25" stands for +2.5V ; "3" stands for +3.0V ; "33" stands for +3.3V
[4]	Nominal Frequency , "K" stands for KHz
[5]	Frequency stability in ±_ ppm ; ex 1 : ± 8.0ppm --- 8.0 , ex 2 : ± 5.0ppm --- 5.0
[6]	Operating temperature range in °C ex 1 : -40 °C to +105°C ----- -40+105 ; ex 2 : -40 °C to +85°C ----- -40+85

Package Dimensions (Unit : mm)

[ME21T]	[ME32T]

Test Circuit and Output Waveform

Test Circuit	CMOS Output Waveform

Temperature Compensated Crystal Oscillators [TCXO " M " and VCTCXO " VM "]

TCXO			VCTCXO			N series	SMD	2.5V	3.3V	Min. 10 MHz	Max. 1,500 MHz
MQN _ T	MQN _ P	MQN _ D	VMQN _ T	VMQN _ P	VMQN _ D						
CMOS	LVPECL	LVDS	CMOS	LVPECL	LVDS						

Features 0.8 pS Phase Jitter (typical)

- Wide frequency range : 10 ~ 1500 MHz
- RMS Jitter (12 kHz ~ 20MHz) : 0.8 ps typ. (at 156.250 MHz)
- Package size : 3.2 x 2.5 x 1.6mm and 7.0 x 5.0 x 2.5mm
- Single end output : CMOS , Differential output : LVPECL or LVDS



General specifications , at Ta=+25°C

Model	(V)MQN326T , (V)MQN574T	(V)MQN326P , (V)MQN576P	(V)MQN326D , (V)MQN576D
Output Logic	CMOS	LVPECL	LVDS
Supply Voltage V _{DD} (code)	+ 2.5 V _{DD} ± 5% (voltage code " 25 ") + 3.3 V _{DD} ± 5% (voltage code " 33 ")	+ 2.5 V _{DD} ± 5% (voltage code " 25 ") + 3.3 V _{DD} ± 5% (voltage code " 33 ")	+ 2.5 V _{DD} ± 5% (voltage code " 25 ") + 3.3 V _{DD} ± 5% (voltage code " 33 ")
Available Frequency Range	10 ~ 250 MHz	10 ~ 1,500 MHz	10 ~ 1,500 MHz
Output Load	15 pF	50 Ω into V _{CC} - 2V or Thevenin equivalent	100 Ω
Output Logic " High " , " 1 "	90 % V _{DD}	V _{DD} - 1.03 (min.) , V _{DD} - 0.6 (max.)	1.4 V (typ.) , 1.6 V (max.)
Output Logic " Low " , " 0 "	10 % V _{DD}	V _{DD} - 1.85 (min.) , V _{DD} - 1.6 (max.)	1.1 V (typ.) , 0.9 V (min.)
(V _{DD} = + 2.5V)	50 MHz : 34 mA	156 MHz : 46 mA	156 MHz : 32 mA
Current Consumption (max.)	125 MHz : 38 mA	600 MHz : 50 mA	800 MHz : 40 mA
	200 MHz : 40 mA	1,000 MHz : 60 mA	1,000 MHz : 44 mA
(V _{DD} = + 3.3V)	50 MHz : 36 mA	156 MHz : 50 mA	156 MHz : 35 mA
Current Consumption (max.)	125 MHz : 40mA	600 MHz : 55 mA	800 MHz : 40 mA
	200 MHz : 44 mA	1,000 MHz : 62 mA	1,000 MHz : 44 mA
Current with Output Disabled	18 mA (typ.)	18 mA (typ.)	18 mA (typ.)
Rise Time / Fall Time	1.5 nsec. (typ.) , 3.0 nsec. (max.) Tr / Tf : 10% ↔ 90% waveform	0.2 nsec. (typ.) , 0.5 nsec. (max.) Tr / Tf : 20% ↔ 80% waveform	0.2 nsec. (typ.) , 0.4 nsec. (max.) Tr / Tf : 20% ↔ 80% waveform

Initial Calibration Tolerance	± 1.0 ppm. (max.) at +25°C±2°C. (upon shipment) for Package Size (3.2 * 2.5 mm)							
	± 2.0 ppm. (max.) at +25°C±2°C. (upon shipment) for Package Size (5.0 * 7.0 mm)							
Frequency Stability Codes	Temperature (ref to +25°C)	± 2.0 ppm over -40°C to +85°C (default) ± 1.0 ppm over -40°C to +85°C (available)						
	Aging at Ta = +25°C	± 1.0 ppm max . , per year at 25°C						
	Voltage Change	± 0.2 ppm max . , for a ±5% input voltage change.						
	Load Change	± 0.2 ppm max . , for a ±10% load condition change.						
	Reflow	± 1.0 ppm max . , 1 reflow and measured 24 hours afterwards.						
Duty Cycle	50 % ± 5%							
Start-up Time	5.0 msec. (max.)							
RMS Jitter [12 kHz ~ 20 MHz]	0.8 psec (typ.)							
Phase Noise [dBc / Hz (typ.)]	Offset	10 Hz	100 Hz	1K Hz	10K Hz	100K Hz	1M Hz	10M Hz
	125 MHz	-51	-93	-111	-123	-125	-135	-155
	212.5 MHz	-42	-87	-105	-115	-118	-130	-151
Storage Temperature	-55°C to + 125°C							

Control Voltage Function on Pad 1		Output Enable Function on pad 2	
Control Voltage Center and Range	+1.5V ± 1.0V for both V _{DD} = 2.5V and 3.3V	OE Control on Pad 2	70% of V _{DD} (min.) to enable output. (Open connection prohibit.)
Frequency Pulling Range	± 8 ppm (min.)		30% of V _{DD} (max.) to disable output (high impedance.)
Linearity	1% (typ.) ; 10% (max.)		
Transfer Function	Positive Transfer	Output Enable Time / Disable Time	200 nsec. (max.) / 50 nsec. (max.)
Absolute Voltage	4.0 V (max.)		
Input Impedance	770 KΩ (typ.)		

Temperature Compensated Crystal Oscillators [TCXO " M " and VCTCXO " VM "]

TCXO			VCTCXO			F series	SMD	2.5V	3.3V	Min. 10 MHz	Max. 1,500 MHz
MQF_T CMOS	MQF_P LVPECL	MQF_D LVDS	VMQF_T CMOS	VMQF_P LVPECL	VMQF_D LVDS						

Features

- Wide frequency range : 10 ~ 1500 MHz
- RMS Jitter (12 KHz ~ 20MHz) : 1.0 ps typ. (at 156.250 MHz)
- Package size : 3.2 x 2.5 x 1.6mm and 7.0 x 5.0 x 2.5mm
- Next-Day sample for prototypes

Quick - Turn Clock Oscillators

1.0 pS Phase Jitter (typical)



General specifications , at Ta=+25°C

Model	(V)MQF326T , (V)MQF574T	(V)MQF326P , (V)MQF576P	(V)MQF326D , (V)MQF576D					
Output Logic	CMOS	LVPECL	LVDS					
Supply Voltage V _{DD} (code)	+ 2.5 V ± 5% (voltage code " 25 ") + 3.3 V ± 5% (voltage code " 33 ")	+ 2.5 V ± 5% (voltage code " 25 ") + 3.3 V ± 5% (voltage code " 33 ")	+ 2.5 V ± 5% (voltage code " 25 ") + 3.3 V ± 5% (voltage code " 33 ")					
Available Frequency Range	10 ~ 250 MHz	10 ~ 1,500 MHz	10 ~ 1,500 MHz					
Output Load	15 pF	50 Ω into V _{cc} - 2V or Thevenin equivalent	100 Ω					
Output Logic " High " , " 1 "	90 % V _{DD}	V _{DD} - 1.03 (min.) , V _{DD} - 0.6 (max.)	1.4 V (Typ.) , 1.6 V (max.)					
Output Logic " Low " , " 0 "	10 % V _{DD}	V _{DD} - 1.85 (min.) , V _{DD} - 1.6 (max.)	1.1 V (Typ.) , 0.9 V (min.)					
(V _{DD} = + 2.5V) Current Consumption (max.)	50 MHz : 34 mA 125 MHz : 38 mA 200 MHz : 40 mA	156 MHz : 46 mA 600 MHz : 50 mA 1,000 MHz : 60 mA	156 MHz : 32 mA 600 MHz : 38 mA 1,000 MHz : 44 mA					
(V _{DD} = + 3.3V) Current Consumption (max.)	50 MHz : 36 mA 125 MHz : 40mA 200 MHz : 44 mA	156 MHz : 50 mA 600 MHz : 55 mA 1,000 MHz : 62 mA	156 MHz : 35 mA 600 MHz : 40 mA 1,000 MHz : 46 mA					
Current with Output Disabled	18 mA (Typ.)	18 mA (Typ.)	18 mA (Typ.)					
Rise Time / Fall Time	1.5 nsec. (Typ.) , 3.0 nsec. (max.) Tr / Tf : 10% ↔ 90% waveform	0.2 nsec. (Typ.) , 0.5 nsec. (max.) Tr / Tf : 20% ↔ 80% waveform	0.2 nsec. (Typ.) , 0.4 nsec. (max.) Tr / Tf : 20% ↔ 80% waveform					
Initial Calibration Tolerance	± 1.0 ppm (max.) at +25°C±2°C (at the shipment) for Package Size (3.2 * 2.5 mm) ± 2.0 ppm (max.) at +25°C±2°C (at the shipment) for Package Size (5.0 * 7.0 mm)							
Frequency Stability Codes	Temperature (refer to +25°C)	± 2.0 ppm over -40°C to +85°C (default for Quick - Turn) ± 1.0 ppm over -40°C to +85°C (available)						
	Aging at Ta = +25°C	± 1.0 ppm (max.) first year						
	Voltage Change	± 0.2 ppm (max.) , for a ±5% input voltage change.						
	Load Change	± 0.2 ppm (max.) , for a ±10% load condition change.						
	Reflow	± 1.0 ppm (max.) , 1 reflow and measured 24 hours afterwards.						
Duty Cycle	50 % ± 5%							
Start-up Time	5 msec (max.)							
Storage Temperature	-55°C to +125°C							
RMS Jitter [12 KHz ~ 20 MHz]	1.0 psec (typ.)							
Phase Noise [dBc / Hz (typ.)]	Offset	10 Hz	100 Hz	1K Hz	10K Hz	100K Hz	1M Hz	10M Hz
	156.250 MHz	-65	-92	-108	-114	-117	-139	-147
	212.500 MHz	-61	-90	-106	-110	-112	-133	-142
	312.500 MHz	-51	-79	-97	-102	-103	-125	-134

Control Voltage Function on Pad 1		Output Enable Function on pad 2		
Control Voltage Center and Range	+1.5V ± 1.0V for both V _{DD} = 2.5V and 3.3V	OE Control on Pad 2	70% of V _{DD} (min.) to enable output. (Open connection prohibit.)	
Frequency Pulling Range	± 8 ppm (min.)		Output Enable Time / Disable Time	30% of V _{DD} (max.) to disable output.
Linearity	1% (typ.) ; 10% (max.)			200 nsec. (max.) / 50 nsec. (max.)
Transfer Function	Positive Transfer			
Absolute Voltage	4.0 V (max.)			
Input Impedance	770 KΩ (typ.)			

Temperature Compensated Crystal Oscillators [TCXO " M " and VCTCXO " VM "]

Part Number Format and Example

	[1]	[2]	[3]	[4]	-	[5]	-	[6]	/	[7]	
	Holder Type	Package Code	Waveform Code	Supply Voltage		Center Frequency		Frequency Stability		Operating Temp. Range	
Examples	(1)	MQN	326	D	25	-	622.080	-	1.0	/	-40+85
	(2)	VMQF	576	P	33	-	120.000	-	2.0	/	-40+85

Ex (1) : MQN326D25 - 622.080 - 1.0 / -40+85 [TCXO , MQN326 type , LVDS , +2.5V , 622.080MHz , ±1.0ppm from -40°C to 85°C]

Ex (2) : VMQF576P33 - 120.000 - 2.0 / -40+85 [VCTCXO , VMQF576 type , LVPECL , +3.3V , 120.000MHz , ±2.0ppm from -40°C to 85°C]

[1]	Holder Type : " MQN " , " MQF " stands for TCXO ; " VMQN " , " VMQF " stands for VCTCXO
[2]	Package Code : " 326 " stands for 3.2 x 2.5 x 1.6 mm 6pad ; " 576 " stands for 5.0 x 7.0 x 2.5 mm 6pad
[3]	Output Waveform Code : " T " stands for CMOS ; " P " stands for PECL ; " D " stands for LVDS
[4]	Supply Voltage : " 25 " stands for +2.5V ; " 33 " stands for +3.3V
[5]	Center Frequency in MHz
[6]	Frequency Stability in ± ppm ; ex 1 : ± 1.0ppm --- 1.0 , ex 2 : ± 2.0ppm --- 2.0
[7]	Operating Temperature Range in °C ex : -40 °C to 85°C ----- -40+85

Outline Dimensions (Unit : mm) , Suggested pad Layout for SMDs

[(V)MQ_574T]	[(V)MQ_576P] , [(V)MQ_576D]	[(V)MQ_326T] , [(V)MQ_326P] , [(V)MQ_326D]
<p>Pad Connections : Pad 1 : NC for TCXO ; VC for VCTCXO Pad 2 : Ground Pad 3 : Output Pad 4 : Supply Voltage</p>	<p>Pad Connections : Pad 1 : NC for TCXO ; VC for VCTCXO Pad 2 : Output Enable Pad 3 : Ground Pad 4 : Output Pad 5 : Complementary Pad 6 : Supply Voltage</p>	<p>Pad Connections : Pad 1 : NC for TCXO ; VC for VCTCXO Pad 2 : Output Enable Pad 3 : Ground Pad 4 : CMOS : Output ; PECL / LVDS : Differential Pad 5 : CMOS : No Connection ; PECL / LVDS : Complementary Pad 6 : Supply Voltage</p>

Test Circuits and Output Waveforms

CMOS for 4pad package	CMOS for 6pad package
<p>NC for TCXO VC for VCTCXO</p>	<p>No Connection for TCXO Voltage Control for VCTCXO</p>
LVPECL	LVDS
<p>VC for VCTCXO NC for TCXO Output Enable</p> <p>$V_{DD} = 3.3V : R1 = R3 = 127 \Omega ; R2 = R4 = 82.5 \Omega$ $V_{DD} = 2.5V : R1 = R3 = 250 \Omega ; R2 = R4 = 62.5 \Omega$</p>	<p>No Connection for TCXO Voltage Control for VCTCXO</p>

Temperature Compensated Crystal Oscillators [TCXO " M " and VCTCXO " VM "]

TCXO	VCTCXO	Quick - Turn Clock Oscillators	250 fsec RMS Jitter	SMD	1.8 V	2.5 V	3.3 V	Min.	Max.
MJF_	VMJF_							15 MHz	2,100 MHz

Features

- Wide frequency range : 15 ~ 2100 MHz
- RMS jitter (12KHz ~ 20MHz) : 250 fsec typ. (at 156.250MHz , 3.3V)
- Next-Day sample for Prototypes
- package size : 5.0 x 3.2mm and 3.2 x 2.5mm

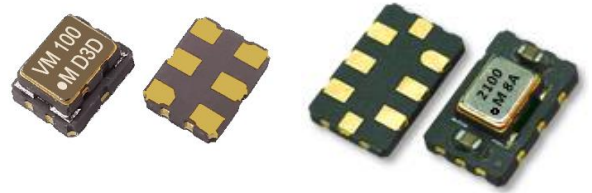

General specifications , at Ta = + 25°C

Model	(V)MJF326P , (V)MJF538P	(V)MJF326D , (V)MJF538D	(V)MJF326C , (V)MJF538C	(V)MJF326Q , (V)MJF538Q
Output Logic	LVPECL	LVDS	HCSL	CML
Supply Voltage V _{DD}	--	+ 1.8 V ± 5% (*)	+ 1.8 V ± 5%	+ 1.8 V ± 5%
	+ 2.5 V ± 5%	+ 2.5 V ± 5%	+ 2.5 V ± 5%	+ 2.5 V ± 5%
	+ 3.3 V ± 5%	+ 3.3 V ± 5%	+ 3.3 V ± 5%	+ 3.3 V ± 5%
Available Frequency Range	15 ~ 2,100 MHz	15 ~ 2,100 MHz	15 ~ 700 MHz	15 ~ 2,100 MHz
Output Load	50 Ω into V _{DD} - 2V or Thevenin equivalent	100 Ω between output and complimentary output	50 Ω to GND	50 Ω to V _{DD}
Output Logic " High " , " 1 "	V _{DD} - 1.03 V (min.) V _{DD} - 0.6 V (max.)	1.4 V (Typ.) 1.6 V (max.)	V _{DD} : 0.66 V (min.) V _{DD} : 1.15 V (max.)	V _{DD} - 0.085 V (min.) V _{DD} = (max.)
Output Logic " Low " , " 0 "	V _{DD} - 1.85 V (min.) V _{DD} - 1.6 V (max.)	1.1 V (Typ.) 0.9 V (min.)	V _{DD} : - 0.15 V (min.) V _{DD} : 0.15 V (max.)	V _{DD} - 0.6 V (min.) V _{DD} - 0.32 V (max.)
Output Voltage Swing	595 mV (min.) 930 mV (max.)	250 mV (min.) 450 mV (max.)	620 mV (min.) 700 mV (typ.)	200 mV (min.) 600 mV (typ.)
Current Consumption (V _{DD} = + 3.3 V)	100 mA (typ.) 120 mA (max.)	75 mA (typ.) 90 mA (max.)	80 mA (typ.) 100 mA (max.)	70 mA (typ.) 85 mA (max.)
Current with Output Disable	99 mA (typ.)	74 mA (typ.)	79 mA (typ.)	69 mA (typ.)
Rise Time / Fall Time (20% to 80% Waveform)	0.4 nsec. (max.)	0.4 nsec. (max.)	0.4 nsec.(max.)	0.4 nsec. (max.)

Initial Calibration Tolerance	± 1.0 ppm (max.) at +25°C ± 2°C.	
Frequency Stability	Temperature (ref to +25°C)	± 1.5 ppm over -40°C to +85°C (default) ± 1.0 ppm over -40°C to +85°C (available)
	Aging at Ta = +25°C	± 1.0 ppm (max.) , per year
	Voltage Change	± 0.2 ppm (max.) , for a ± 5% input voltage change.
	Load Change	± 0.2 ppm (max.) , for a ± 10% load condition change.
	Reflow	± 1.0 ppm (max.) , 1 reflow and measured 24 hours afterwards.
Duty Cycle	50 % ± 5%	
Start-up Time	5 msec (typ.) ; 10 msec (max.)	
Storage Temperature	-55°C to +150°C	
RMS Jitter (typ.) (12 KHz to 20 MHz)	15 MHz ~ 50 MHz : 500 fsec (typ.) , 51MHz ~ 1,200 MHz : 250 fsec (typ.)	

Control Voltage Function on Pad 1		Output Enable Function on pad 2	
Control Voltage Center and Range	+ 1.5V ± 1.0V for both V _{DD} = 2.5V and 3.3V	Output Enable / Disable Function	70% of V _{DD} (min.) to enable output.
	+ 0.9V ± 0.6V for both V _{DD} = 1.8V		30% of V _{DD} (max.) to disable output
Frequency Pulling Range	± 8 ppm (min.)	Output Enable Time	2.5 msec (max.)
Linearity	1% (typ.) ; 10% (max.)		
Transfer Function	Positive Transfer	Output Disable Time	10 usec (max.)
Input Impedance	5 MΩ (typ.)		

Note * : This needs AC coupling (100-nF series capacitor). Please check the test circuit.

Temperature Compensated Crystal Oscillators [TCXO " M " and VCTCXO " VM "]

TCXO	VCTCXO	Quick - Turn Clock Oscillators	250 fsec RMS Jitter	SMD	1.8 V	2.5 V	3.3 V	Min.	Max.
MJF_	VMJF_							15	MHz

Part Number Format and Example

[1]	[2]	[3]	[4]	-	[5]	-	[6]	/	[7]
Holder Type	Package Code	Waveform Code	Supply Voltage		Center Frequency		Frequency Stability		Operating Temp. Range

Examples	(1)	MJF	326	D	33	-	156.250	-	1.0	/	-20+70
	(2)	VMJF	538	C	18	-	100.000	-	1.5	/	-40+85

Ex (1) : MJF326D33 - 156.250 - 1.0 / -20+70 [TCXO , MJF326 type , LVDS , +3.3V , 156.250MHz , ±1.0ppm from -20°C to 70°C]

Ex (2) : VMJF538C18 - 100.000 - 1.5 / -40+85 [VCTCXO , VMJF538 type , HCSL , +1.8V , 100.000MHz , pulling : ±8ppm min. , ±1.5ppm from -40°C to 85°C]

[1]	Holder Type : " MJF " stands for TCXO ; " VMJF " stands for VCTCXO
[2]	Package Code : " 326 " stands for 3.2 x 2.5 x 1.6 mm 6pad ; " 538 " stands for 5.0 x 3.2 x 1.4 mm 8pad
[3]	Output Waveform Code : " P " stands for LVPECL ; " D " stands for LVDS ; " C " stands for HCSL ; " Q " stands for CML
[4]	Supply Voltage : " 18 " stands for +1.8V ; " 25 " stands for +2.5V ; " 33 " stands for +3.3V
[5]	Center Frequency in MHz
[6]	Frequency Stability in ± ppm ; ex 1 : ± 1.0ppm --- 1.0 , ex 2 : ± 1.5ppm --- 1.5
[7]	Operating Temperature Range in °C ex 1 : -20 °C to 70°C ----- -20+70 ; ex 2 : -40 °C to 85°C ----- -40+85

Outline Dimensions (Unit : mm) , Suggested pad Layout for SMDs

MJF538_ , VMJF538_	MJF326_ , VMJF326_
<p>Top View 5.0 ± 0.1 3.2 ± 0.1</p> <p>Bottom View 0.6, 0.6, 0.9, 0.6, 2.54, 0.6</p> <p>Land Pattern 1.0, 0.8, 2.1, 2.54</p> <p>Side View 2.5 ± 0.1, 1.4 ± 0.1, 0.6</p> <p>Pad Connection : Pad 1 : Ground for TCXO VC for VCTCXO Pad 2 : Output Enable Pad 3 : Ground Pad 4 : Output</p> <p>Pad 5 : Complementary Pad 6 : Supply voltage Pad 7 : Do Not Connet Pad 8 : Do Not Connet</p>	<p>Top View 3.2 ± 0.1 2.5 ± 0.1</p> <p>Bottom View 0.6, 0.6, 0.8, 0.6, 2.4, 0.6</p> <p>Land Pattern 0.9, 1.6, 1.1, 2.4</p> <p>Side View 2.5 ± 0.1, 1.6 ± 0.1, 0.7</p> <p>Pad Connection : Pad 1 : Ground for TCXO VC for VCTCXO Pad 2 : Output Enable Pad 3 : Ground Pad 4 : Output Pad 5 : Complementary Pad 6 : Supply voltage</p>

Test Circuits

LVPECL Test Circuit	HCSL Test Circuit	
<p>VDD, 10uF, 0.1uF, R1, R3, R2, R4, VC/NC OE</p> <p>VDD = 3.3 V : R1 = R3 = 127Ω ; R2 = R4 = 82.5Ω VDD = 2.5 V : R1 = R3 = 250Ω ; R2 = R4 = 62.5Ω</p>	<p>VDD, 10uF, 0.1uF, 33Ω, 33Ω, 50Ω, 50Ω, VC/NC OE</p>	
CML Test Circuit	LVDS Test Circuit for 2.5V and 3.3V	LVDS Test Circuits for 1.8V only ^(*)
<p>VDD, 10uF, 0.1uF, 50Ω, 50Ω, VC/NC OE</p>	<p>VDD, 10uF, 0.1uF, 100Ω, VC/NC OE</p>	<p>VDD, 10uF, 0.1uF, 0.1uF, 50Ω, 50Ω, Vocm 1.2V, 0.1uF, VC/NC OE</p>

Note * : The 50-ohm termination resistors along with the bias voltage (Vocm) is required to be set at the destination circuit as shown in the figure.

Temperature Compensated Crystal Oscillators [TCXO " M "]

CMOS Output

CMOS Wave Output Code " T " [SMD Type]

TCXO

M_1T

Output Enable / Disable

-40 to +85 °C

CMOS

SMD

15pF

1.8 V

2.5 V

3.3 V

Min.

9.5 MHz

Max.

60 MHz

Features

- Wide frequency range : [9.5 MHz ~ 60.0 MHz]
- Frequency stability as tight as ± 2.5 ppm over -40°C to 85°C
- Frequency stability as tight as ± 5.0 ppm over -40°C to 105°C (available)

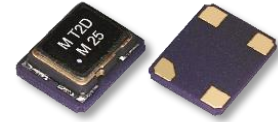

General specifications of all available packages , at Ta=+25°C , CL=15pF

Output Waveform	Square wave [CMOS] . Waveform code is " T "		
Type	M211T	M221T	M321T
Package (Size)	2.05 x 1.65 x 0.70 mm	2.5 x 2.0 x 0.8 mm	3.2 x 2.5 x 1.2 mm
Frequency Range	10.0 ~ 52.0 MHz	9.5 ~ 60.0 MHz	9.5 ~ 60.0 MHz

Output Waveform	Adapter Board Type	
Type	M531T-AB	M571T-AB
Package (Size)	5.0 x 3.2 x 1.3 mm	7.0 x 5.0 x 1.4 mm
Frequency Range	9.5 ~ 60.0 MHz	9.5 ~ 60.0 MHz

Supply Voltage Range	+ 1.8 V (code is " 18 ")		+ 2.5 V (code is " 25 ")		+ 3.3 V (code is " 33 ")	
Current Consumption	6 mA (max.)		7 mA (max.)		8 mA (max.)	
Standard Frequency [MHz]	12.000 , 20.000 , 24.000 , 25.000 , 26.000 , 40.000 , 50.000 , 60.000					
Initial Calibration Tolerance	± 2.0 ppm (max.) at +25°C ± 2 °C. after reflow					
Frequency Stability	± 2.5 ppm		± 5.0 ppm		± 10.0 ppm	
Frequency Stability vs Temperature	- 40°C to + 85°C		○		○	
	- 40°C to + 105°C		△		○	
Frequency Stability	vs Aging at Ta= + 25°C		± 1.0 ppm (max.) , per year			
	vs Voltage Change		± 0.3 ppm (max.) , for a $\pm 5\%$ input voltage change .			
	vs Load Change		± 0.3 ppm (max.) , for a $\pm 10\%$ load condition change .			
Output Logic High " 1 "	V _{DD} of 80% (min.)					
Output Logic Low " 0 "	V _{DD} of 20% (max.)					
Rise Time and fall time	10.0 nsec. (max.) ; 10% \leftrightarrow 90% of the waveform					
Duty Cycle	50 % \pm 5 %					
Start-Up Time.	5.0 msec. (max.)					
Output Load	15 pF					
Output Enable / Disable Function on Pad1 (Don't use in the OPEN condition)	V _{DD} of 80% (min.) to enable output					
	V _{DD} of 20% (max.) to disable output					
RMS Jitter (12KHz ~ 20MHz)	0.3 psec (typ.) , 1.0 psec (max.)					
Phase Noise Offset / dBc / Hz [typ.]	50MHz as example		10 Hz	100 Hz	1 KHz	10 KHz
			-85 dBc / Hz	-111 dBc / Hz	-133 dBc / Hz	-149 dBc / Hz
Storage Temperature	-55°C to +125°C					

TCXOs

Temperature Compensated Crystal Oscillators [TCXO " M "]

CMOS Wave Output Code " T " [SMD Type]

Part Number Format and Exmple

	[1]	[2]	[3]	[4]	-	[5]	-	[6]	/	[7]	-	[8]
	Holder Type	Enable/Disable Function	Output Wave	Supply Voltage		Center Frequency		Frequency Stability		Operating Temp. Range		Adapter Board
Examples	(1)	M32	1	T	33	-	40.000	-	5.0	/	-40+105	
	(2)	M57	1	T	33	-	10.000	-	2.5	/	-40+85	- AB

Ex (1) : M321T33 - 40.000 - 5.0 / -40+105 [TCXO , 3225 SMD package , OE on pad1 , CMOS output , 3.3V , 40.000MHz , ±5.0ppm from -40°C to 105°C]

Ex (2) : M571T33 - 10.000 - 2.5 / -40+85 - AB [TCXO , 7050 SMD package , OE on pad1 , CMOS output , 3.3V , 10.000MHz , ±2.5ppm from -40°C to 85°C , Adapter Board]

[1]	Holder Type " M " stands for TCXO
[2]	Enable / Disable Function on pad1 , ex M321 --- OE on pad1
[3]	" T " stands for Square Wave ex : M321T --- TCXO , 3225 SMD package , CMOS output
[4]	Supply voltage , " 18 " stands for +1.8V ; " 25 " stands for +2.5V ; " 33 " stands for +3.3V
[5]	Center Frequency in MHz
[6]	Frequency stability in ± ppm ; ex 1 : ± 2.5ppm --- 2.5 , ex 2 : ± 5.0ppm --- 5.0
[7]	Operating temperature range in °C ex 1 : -40 °C to 105°C ----- -40+105 ; ex 2 : -40 °C to 85°C ----- -40+85
[8]	Adapter Board Type ----- AB

Outline Dimensions (Unit : mm) , Suggested pad Layout for SMDs

[M211T]	[M221T]

Outline Dimensions (Unit : mm) , Adapter Board Type

[M531T__AB]	[M571T__AB]

Temperature Compensated Crystal Oscillators [TCXO " M "]

CMOS Output

TCXO	VCTCXO	Quick - Turn Clock Oscillators	CMOS	1.8 V	2.5 V	3.3 V	Min.	Max.
MTF_T	VMTF_T						1 MHz	200 MHz

Features

1.2 pS Phase Jitter (typical)

- Programmable low cost CMOS TCXO
- High frequency range : [1 MHz ~ 200 MHz]
- Frequency stability as tight as ± 2.0 ppm over -40°C to 85°C

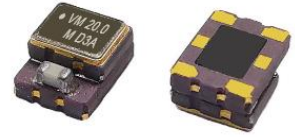

General specifications of all available packages , at $T_a=+25^{\circ}\text{C}$, $CL=15\text{pF}$

Output Waveform		Square wave [CMOS] . Waveform code is " T "				
Type		MTF326 , VMTF326		MTF538 , VMTF538		
Package Size		3.2 x 2.5 x 1.6 mm		5.0 x 3.2 x 1.4 mm		
Supply Voltage (V_{DD})		+ 1.8 V (code is " 18 ")	+ 2.5 V (code is " 25 ")	+ 3.3 V (code is " 33 ")		
Available Frequency Range		1 ~ 125 MHz	1 ~ 200 MHz	1 ~ 200 MHz		
Current Consumption		30 mA (max.)	35 mA (max.)	40 mA (max.)		
Initial Calibration Tolerance		± 2.0 ppm at $+25^{\circ}\text{C} \pm 2^{\circ}\text{C}$. (Default for Quick - Turn)				
Frequency Stability	vs Temperature	± 2.0 ppm (max.) at -40°C to 85°C (Default for Quick - Turn)				
	vs Aging at $T_a = + 25^{\circ}\text{C}$	± 1.0 ppm (max.) , per year				
	vs Voltage Change	± 0.3 ppm (max.) , for a $\pm 5\%$ input voltage change .				
	vs Load Change	± 0.3 ppm (max.) , for a $\pm 10\%$ load condition change .				
	vs Reflow	± 1.0 ppm (max.) , 1 reflow and measured 24 hours afterwards .				
Output Logic High " 1 "		$V_{DD} - 0.4$ V (min.)				
Output Logic Low " 0 "		0.4 V (max.)				
Rise Time and Fall Time		10.0 nsec (max.) ; 10% \leftrightarrow 90% of the waveform				
Duty Cycle	1 ~ 150MHz : 50 % \pm 5 %					
	150 ~ 200MHz : 50 % \pm 10 %					
Start-Up Time		5.0 msec. (typ.) , 10.0 msec. (max.)				
Output Load		15 pF				
Electrical Frequency Tuning (EFC) by external Control Voltage	Control Voltage Center	1.8 V	2.5 V	3.3 V		
	Frequency Deviation Range	0.9 V \pm 0.6 V		1.4 V \pm 1.0 V		
Control Voltage	Slope Polarity (Transfer Function)	Positive slope. Positive voltage for positive frequency shift.				
		Input Impedance : 1.0M Ω (min.)	Modulation Bandwidth : 3 KHz (min.)	Linearity : $\pm 10\%$ (max.)		
Output Enable / Disable Function		70% of V_{DD} (min.) to enable.				
		30% of V_{DD} (max.) to disable.				
		Disable Current : 0.2 mA (typ.) , 1.0 mA (max.)				
RMS Jitter (12KHz ~ 20MHz)	100MHz as example	1.2 psec (typ.)				
Phase Noise		10 Hz	100 Hz	1 KHz	10 KHz	100 KHz
Offset / dBc / Hz (typ.)		-72 dBc / Hz	-101 dBc / Hz	-115 dBc / Hz	-121 dBc / Hz	-119 dBc / Hz
Storage Temperature		-55°C to $+150^{\circ}\text{C}$				

TCXOs

Temperature Compensated Crystal Oscillators [TCXO " M "]

CMOS Wave Output Code " T "

Part Number Format and Exmple

	[1]	[2]	[3]		[4]		[5]		[6]
	Holder Type	Output Wave	Supply Voltage	-	Center Frequency	-	Frequency Stability	/	Operating Temp. Range

Examples	(1)	MTF538	T	33	-	133.330	-	1.0	/	-40+85
	(2)	VMTF326	T	18	-	100.000	-	2.0	/	-10+60

Ex (1) : MTF538T33 - 133.330 - 1.0 / -40+85 [TCXO , 5032 SMD package , CMOS , 3.3V , 133.330MHz , ±1.0ppm from -40°C to 85°C]

Ex (2) : VMTF326T18 - 100.000 - 2.0 / -10+60 [VCTCXO , 3225 SMD package , CMOS , 1.8V , 100.000 MHz , ±2.0ppm from -10°C to 60°C]

[1]	Holder Type " MTF " stands for TCXO ; " VMTF " stands for VCTCXO
[2]	" T " stands for Square Wave
[3]	Supply voltage : " 18 " stands for +1.8V ; " 25 " stands for +2.5V ; " 33 " stands for +3.3V
[4]	Center Frequency in MHz
[5]	Frequency stability in ±_ ppm ; ex 1 : ± 1.0ppm --- 1.0 , ex 2 : ± 2.0ppm --- 2.0
[6]	Operating temperature range in °C ex 1 : -40 °C to 85°C ----- -40+85 ; ex 2 : -10 °C to 60°C ----- -10+60

Outline Dimensions (Unit : mm) , Suggested pad Layout for SMDs

[(V) MTF326T]	[(V) MTF538T]
<div style="display: flex; justify-content: space-around;"> <div style="text-align: center;"> <p>Top View</p> </div> <div style="text-align: center;"> <p>Bottom View</p> </div> <div style="text-align: center;"> <p>Land Pattern</p> </div> </div> <div style="margin-top: 10px;"> <p>Side View</p> </div> <div style="margin-top: 10px;"> <p>Pad Connections : Pad 1: No Connection for TCXO Voltage Control for VCTCXO Pad 2: Output Enable Pad 3: Ground Pad 4: Output Pad 5: No Connection Pad 6: Supply Voltage</p> </div>	<div style="display: flex; justify-content: space-around;"> <div style="text-align: center;"> <p>Top View</p> </div> <div style="text-align: center;"> <p>Side View</p> </div> <div style="text-align: center;"> <p>Bottom View</p> </div> </div> <div style="margin-top: 10px;"> <p>Land Pattern</p> </div> <div style="margin-top: 10px;"> <p>Pad Connections : Pad1 : No Connection For TCXO Voltage Control For VCTCXO Pad2 : Output Enable Pad3 : Ground Pad4 : Output Pad5 : No Connection Pad6 : Supply Voltage Pad7 : No Connection Pad8 : No Connection</p> </div>

" OCXO " [Oven Controlled Crystal Oscillators]

" OC__E " series (True Sine Wave)

" OC__S " series (Clipped Sine Wave)

" OC__T " series (Square Wave)

What is an OCXO ?

Relatively speaking , an OCXO perform in the $\pm 0.01 \sim \pm 0.1\text{ppm}$ range , a TCXO performs in the $\pm 1.0 \sim \pm 5.0\text{ppm}$ range while a non - compensated clock oscillator performs in the ± 25 with $\pm 50\text{ppm}$ range .

A TCXO relies upon on a resistor / capacitor compensation network to counter the crystal's temperature - dependent frequency behavior . An OCXO has a crystal that is " ovenized " . This means the crystal " sees " a constant temperature regardless of the ambient temperature condition . The oven consists of a proportional heater (power transistor) and an automatic gain control (AGC) circuit . Also , a thermister monitors the oven temperature and sends an offset signal to the AGC which then turns the power transistor on and off accordingly . Thermal gradient and heat loss are carefully controlled to minimize the set point fluctuation of the oven . The oven temperature is normally set near the upper tuning point (UPT) of the crystal's freq. - temp. curve . At the UPT , the slope is zero and ideally there is no frequency change if the crystal " sees " a constant temperature .

Applications for OCXOs include satellite radio beacons , Stratum 3 systems , PCS / GMS base stations , SONET clocks , frequency synthesizers and instrumentation .

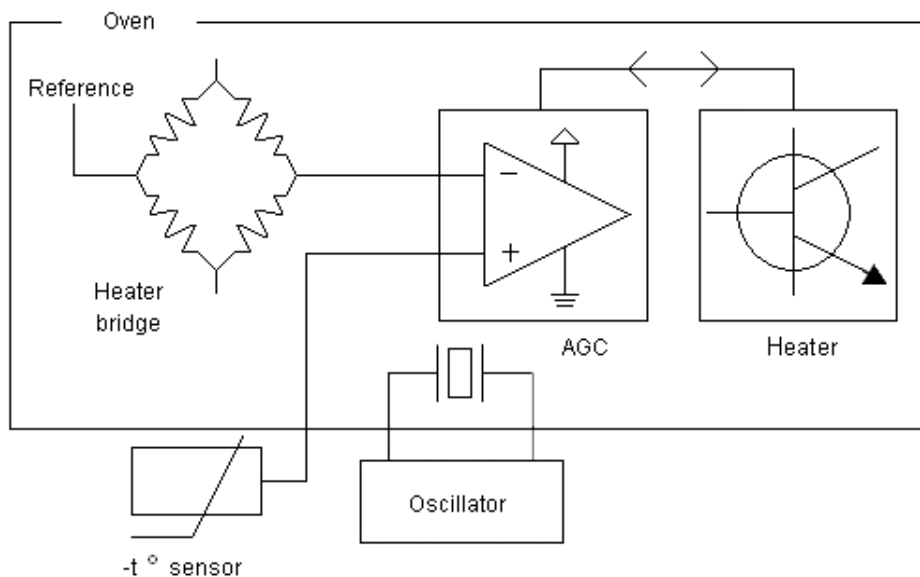
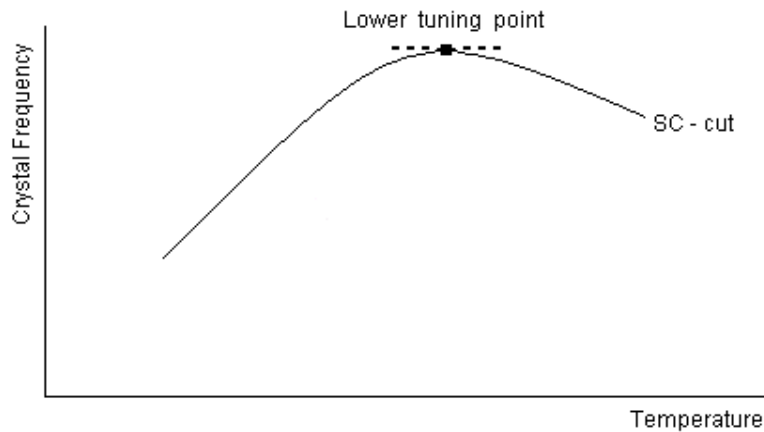

OCXOs

" OCXO " [Oven Controlled Crystal Oscillators]

OC12T Square Wave	OC12E True Sine Wave	Best stability ± 10 ppb	Standard OCXO Series	SMD	3.3V	5.0V	Min. 5 MHz	Max. 40 MHz
-----------------------------	--------------------------------	-----------------------------------	--------------------------------	------------	-------------	-------------	----------------------	-----------------------

Applications

- OC12_ (25.4 * 22.1 * 11.0 mm)
- +3.3V , +5.0V Supply Voltages
- Voltage control (Electronic Frequency Tuning) is standard .

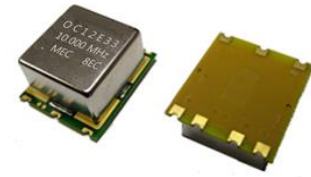

General Specifications (at+25°C and specified input voltage)

Output Waveform		Square wave. Waveform code is " T "		True Sine Wave. Waveform code is " E "			
Supply Voltage		+3.3 V	+5.0 V	+3.3 V	+5.0 V		
Supply Voltage range , " Voltage code "		+3.3V ± 5% , " 3 "	+5.0V ± 5% , " 5 "	+3.3V ± 5% , " 3 "	+5.0V ± 5% , " 5 "		
Frequency Range		5 ~ 40.0 MHz		5 ~ 40.0 MHz			
Initial Calibration Tolerance		± 200 ppb (max.)	± 200 ppb (max.)	± 200 ppb (max.)	± 200 ppb (max.)		
		Vcon = +1.65 V	Vcon = +2.5 V	Vcon = +1.65 V	Vcon = +2.5 V		
Type of Crystal Cut Used		" SC - cut " crystal or " IT - cut " crystal					
Frequency Stability		± 5 ppb (max.) over 0°C to +70°C					
		± 10 ppb (max.) over -30°C to +70°C					
		± 10 ppb (max.) over -40°C to +85°C					
		vs Voltage Change ± 0.5 ppb (max.) , for a ± 5% input voltage change .					
Voltage Control		vs Warm-up time (+25°C) 10 minute (max.) Within ± 10 ppb of its reference frequency.					
		vs Aging ± 0.5 ppb (max.) / after 30 days ; ± 50 ppb (max.) / first year ; ± 400 ppb (max.) over 10 years.					
On pin 1 (EFC)		Freq. Deviation Range		± 0.5 ppm (min.) , ± 5 ppm (max.) Reference to fo at +25°C and over operating temperature range.			
		Control Voltage Range		+1.65V ± 1.65V	+2.5V ± 2.5V	+1.65V ± 1.65V	+2.5V ± 2.5V
(Electronic Freq. Tuning)		Transfer Function Positive : Increasing control voltage increases output frequency .					
		Input Impedance		50 K ohms (min.)			
Power		EFC Linearity ± 10 % (max.)					
		Power Dissipation (at +25°C)		1.2 Watts (max.) at steady-state; 1000 mA (max.) at turn-on.			
Output		Output Level (for True Sine)		---	---	+8 dBm (typ.) , +10 dBm (max.)	
		Harmonic (for True Sine)		---	---	-30 dBc (max.)	
		Spurious (for True Sine)		---	---	-60 dBc (max.)	
		Load		15pF		50 Ω	
		Output Logic High (V _{OH})		+2.4 V (min.)	+2.4 V (min.)	---	---
		Output Logic Low (V _{OL})		+ 0.4 V (max.)	+ 0.4 V (max.)	---	---
		Duty Cycle (V _{DD})		50 % ± 5% @ +1.4V			
		Rise and Fall Time		7 nsec. (max.) (20% → 80% of waveform)			
Phase Noise Offset [10.0 MHz] (typ.)		1 Hz		10 Hz	1 KHz	10 KHz	
		-98 dBc		-126 dBc	-145 dBc	-152 dBc	

Outline Dimensions (Unit : ±0.2 mm)

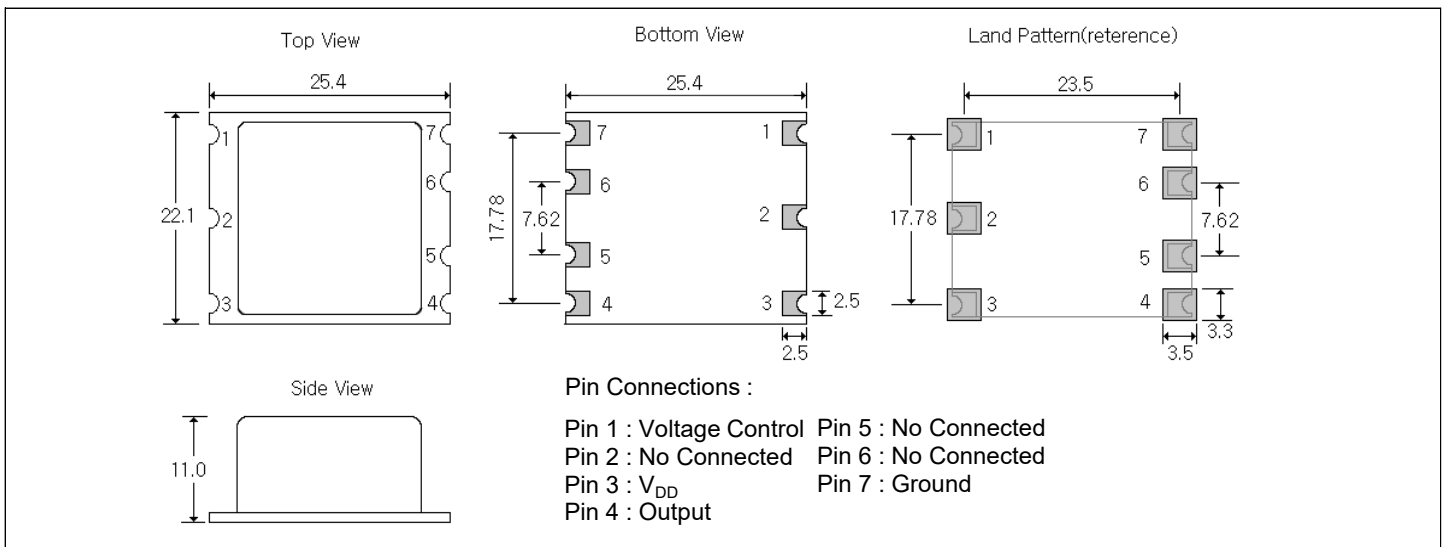

" OCXO " [Oven Controlled Crystal Oscillators]

OC13T

Square Wave

OC13E

True Sine Wave

Best stability

± 5.0 ppb

Standard
OCXO Series

DIP

3.3V

5.0V

Min.

5 MHz

Max.

40 MHz

Applications

- OC13_ (25.4 * 25.4 * 12.7 mm)
- Full Size 5 pin dip full metal package
- +3.3V , +5.0V Supply Voltages
- Voltage control (Electronic Frequency Tuning) is standard .



General Specifications (at+25°C and specified input voltage)

Output Waveform		Square wave. Waveform code is " T "		True Sine Wave. Waveform code is " E "	
Supply Voltage		+3.3 V	+5.0 V	+3.3 V	+5.0 V
Supply Voltage range , " Voltage code "		+3.3V ± 5% , " 3 "	+5.0V ± 5% , " 5 "	+3.3V ± 5% , " 3 "	+5.0V ± 5% , " 5 "
Frequency Range		5 ~ 40.0 MHz		5 ~ 40.0 MHz	
Initial Calibration Tolerance		± 100 ppb (max.)	± 100 ppb (max.)	± 100 ppb (max.)	± 100 ppb (max.)
		Vcon = +1.65 V	Vcon = +2.5 V	Vcon = +1.65 V	Vcon = +2.5 V
Type of Crystal Cut Used		" SC - cut " crystal or " IT - cut " crystal			
Frequency Stability	vs Temperature (refer to +25°C)	± 3 ppb (max.) over 0°C to +70°C			
		± 5.0 ppb (max.) over -30°C to +70°C			
		± 5.0 ppb (max.) over -40°C to +85°C			
	vs Voltage Change	± 1.0ppb (max.) , for a ± 5% input voltage change .			
	vs Warm-up time (+25°C)	10 minute (max.) Within ± 10 ppb of its reference frequency.			
	vs Aging	± 0.5 ppb (max.) / after 30 days ; ± 50 ppb (max.) / first year ; ± 300 ppb (max.) over 10 years.			
Voltage Control On pin 1 (EFC)	Freq. Deviation Range	± 0.5 ppm (min.) , ± 5 ppm (max.) Reference to fo at +25°C and over operating temperature range.			
	Control Voltage Range	+1.65V ± 1.65V	+2.5V ± 2.5V	+1.65V ± 1.65V	+2.5V ± 2.5V
	Transfer Function	Positive : Increasing control voltage increases output frequency .			
(Electronic Freq. Tuning)	Input Impedance	50 K ohms (min.)			
	EFC Linearity	± 10 % (max.)			
Power	Power Dissipation (at +25°C)	1.3 Watts (max.) at steady-state; 1000 mA (max.) at turn-on.			
Output	Output Level (for True Sine)	---	---	+8 dBm (typ.) , +10 dBm (max.) into 50Ω load .	
	Harmonic (for True Sine)	---	---	-30 dBc (min.)	
	Spurious (for True Sine)	---	---	-60 dBc (min.)	
	Load	15pF		50 Ω	
	Output Logic High (V _{OH})	+2.4 V (min.)	+2.4 V (min.)	---	---
	Output Logic Low (V _{OL})	+ 0.4 V (max.)	+ 0.4 V (max.)	---	---
	Duty Cycle (V _{DD})	50 % ± 5% @ +1.4V			
	Rise and Fall Time	7 nsec. (max.) (20% → 80% of waveform)			
	Phase Noise Offset [10.0 MHz] (typ.)	10 Hz	100 Hz	1 KHz	10 KHz
-120 dBc		-135 dBc	-145 dBc	-150 dBc	

Outline Dimensions (Unit : ±0.2 mm)

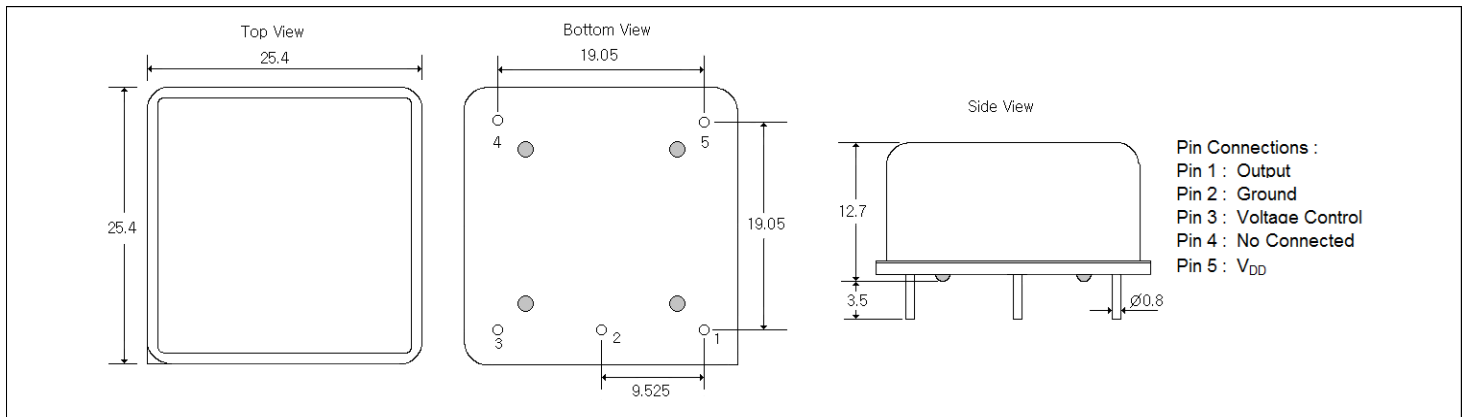

" OCXO " [Oven Controlled Crystal Oscillators]

OC14T

Square Wave

Best stability

± 30 ppb

Voltage Control

DIP

3.3V

5.0V

Min.

5 MHz

Max.

40 MHz

Applications

- OC14_ (20.3 * 12.7 * 11.0 mm)
- +3.3V , +5.0V Supply Voltages
- Voltage control (Electronic Frequency Tuning) is standard .



General Specifications (at+25°C and specified input voltage)

Output Waveform		Square wave . Waveform code is " T "			
Supply Voltage		+3.3 V		+5.0 V	
Supply Voltage range , " Voltage code "		+3.3V ± 5% , " 3 "		+5.0V ± 5% , " 5 "	
Frequency Range		5 ~ 40.0 MHz Standard Frequency : 10.0 MHz		5 ~ 40.0 MHz Standard Frequency : 10.0 MHz	
Initial Calibration Tolerance		± 500 ppb (max.)		± 500 ppb (max.)	
		Vcon = +1.65 V		Vcon = +2.5 V	
Type of Crystal Cut Used		" SC - cut " crystal or " IT - cut " crystal			
Frequency Stability	vs Temperature (refer to +25°C)	± 50 ppb (max.) over 0°C to +70°C			
		± 100 ppb (max.) over -30°C to +70°C			
		± 100 ppb (max.) over -40°C to +85°C			
	vs Voltage Change	± 50ppb (max.) , for a ± 5% input voltage change .			
	vs Warm-up time (+25°C)	10 minute max. Within ± 100 ppb of its reference frequency.			
vs Aging	± 5 ppb max./after 30 days ; ± 500 ppb max./first year ; ± 3 ppm max.over 10 years.				
Voltage Control	Freq. Deviation Range	> ± 5 ppm Reference to fo at +25°C and over operating temperature range.			
On pin 1 (EFC)	Control Voltage Range	+1.65V ± 1.65V		+2.5V ± 2.5V	
	Transfer Function	Positive : Increasing control voltage increases output frequency .			
(Electronic Freq. Tuning)	Input Impedance	50 K ohms min.			
	EFC Linearity	± 10 % (max.)			
Power	Power Dissipation (at +25°C)	0.8 Watts max. at steady-state; 600 mA max. at turn-on.			
Output	Output Logic High (V _{OH})	+2.4 V (min.)		+2.4 V (min.)	
	Output Logic Low (V _{OL})	+ 0.5 V (max.)		+ 0.5 V (max.)	
	Duty Cycle (V _{DD})	50 % ± 5% @ + 2.0V			
	Output Load	15pF			
	Rise and Fall Time	7 nS (max.) (20% → 80% of waveform)			
	Phase Noise Offset [10.0 MHz] (typical)	1 Hz	10 Hz	1 KHz	10 KHz
		-70 dBc	-108 dBc	-140 dBc	-150 dBc

Outline Dimensions (Unit : ±0.2 mm)

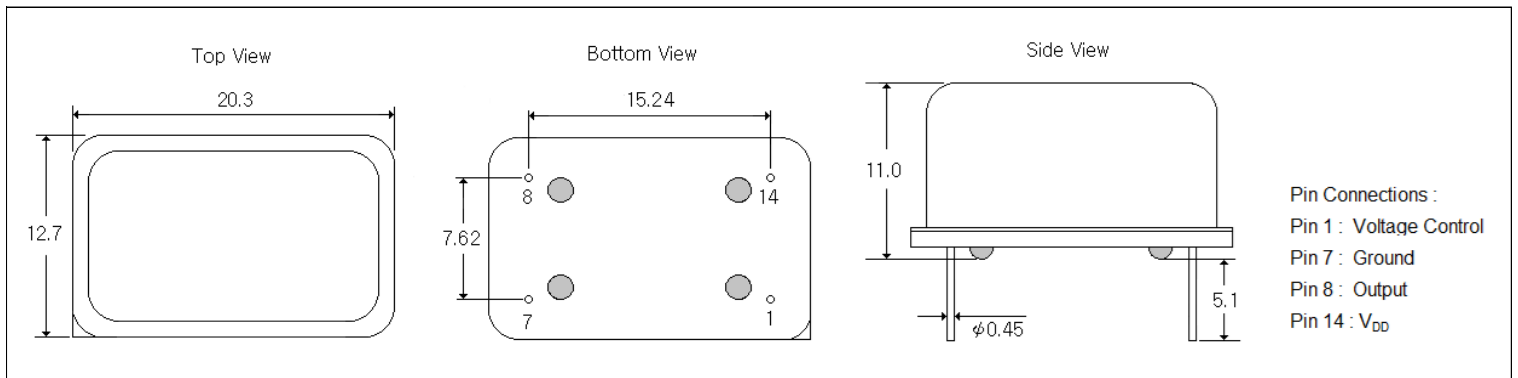

" OCXO " [Oven Controlled Crystal Oscillators]

OC18T	OC19T	Best stability ± 10 ppb	Standard OCXO Series	DIP	3.3V	5.0V	Min. 5 MHz	Max. 40 MHz
Square Wave	Square Wave							

Applications

- OC18 / OC19 _ (20.6 * 20.6 * 11.0 mm) typical
- Full Size 5 pin dip full metal package
- +3.3V , +5.0V Supply Voltages
- Voltage control (Electronic Frequency Tuning) is standard



General Specifications (at+25°C and specified input voltage)

Output Waveform	Square wave . Waveform code is " T "			
Supply Voltage	+3.3 V		+5.0 V	
Supply Voltage range , " Voltage code "	+3.3V ± 5% , " 3 "		+5.0V ± 5% , " 5 "	
Frequency Range	5 ~ 40.0 MHz Standard Frequency : 10.0 MHz		5 ~ 40.0 MHz Standard Frequency : 10.0 MHz	
Initial Calibration Tolerance	± 500 ppb (max.)		± 500 ppb (max.)	
	Vcon = +1.65 V		Vcon = +2.5 V	
Type of Crystal Cut Used	" SC - cut " crystal or " IT - cut " crystal			
Frequency Stability	vs Temperature (refer to +25°C)	± 5 ppb (max.) over 0°C to +70°C		
		± 10 ppb (max.) over -30°C to +70°C		
		± 10 ppb (max.) over -40°C to +85°C		
	vs Voltage Change	± 0.5ppb (max.) , for a ± 5% input voltage change .		
	vs Warm-up time (+25°C)	3 minute max. Within ± 50 ppb of its reference frequency.		
	vs Aging	± 0.5 ppb max./after 30 days ; ± 50 ppb max./first year ; ± 300 ppb max. over 10 years.		
Voltage Control On pin 1 (EFC)	Freq. Deviation Range	± 0.5 ppm min, ± 2 ppm max. Reference to fo at +25°C and over operating temperature range.		
	Control Voltage Range	+1.65V ± 1.65V		+2.5V ± 2.5V
	Transfer Function	Positive : Increasing control voltage increases output frequency .		
(Electronic Freq. Tuning)	Input Impedance	100 K ohms min.		
	EFC Linearity	± 10 % (max.)		
Power	Power Dissipation (at +25°C)	1.3 Watts max. at steady-state; 800 mA max. at turn-on.		
Output	Output Logic High (V _{OH})	+2.4 V (min.)		+3.5 V (min.)
	Output Logic Low (V _{OL})	+ 0.5 V (max.)		+ 0.5 V (max.)
	Duty Cycle (V _{DD})	50 % ± 5% @ 2.0V		
	Load	15pF		
	Rise and Fall Time	7 nS (max.) (20% → 80% of waveform)		
	Phase Noise Offset [20.0 MHz] (typical)	10 Hz -115 dBc	100 Hz -135 dBc	1 KHz -145 dBc

Outline Dimensions (Unit : ±0.2 mm)

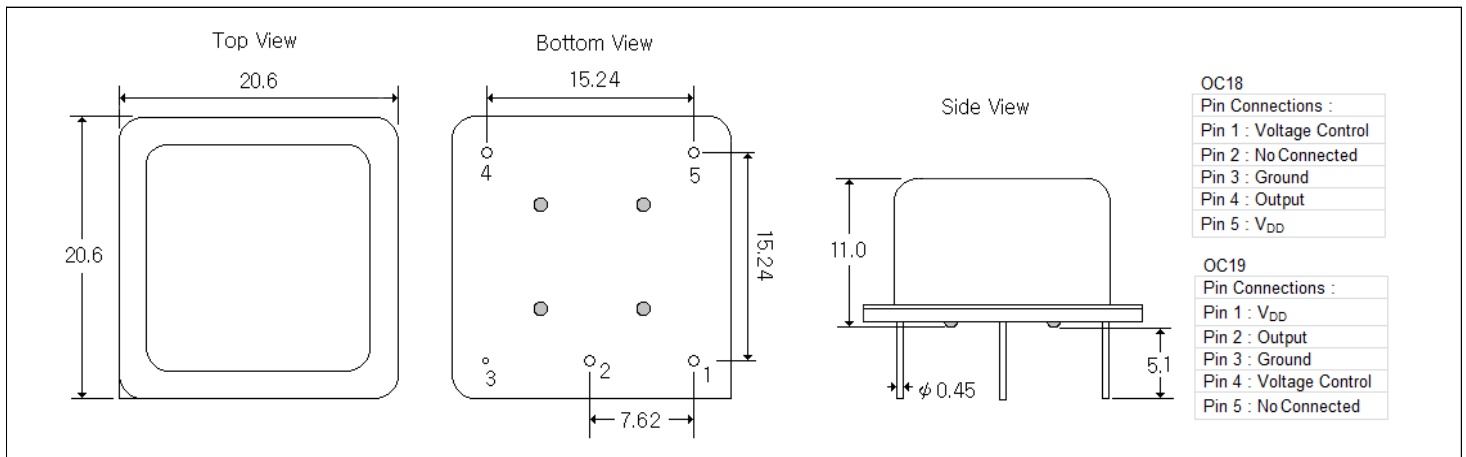

" OCXO " [Oven Controlled Crystal Oscillators]

OC32T

Square Wave

OC32E

True Sine Wave

Best stability

± 5.0 ppb

Standard
OCXO Series

DIP

3.3V

5.0V

Min.

5 MHz

Max.

40 MHz

Applications

- OC32_ (36.3 * 27.2 * 12.7 mm)
- Full Size 5 pin dip full metal package
- +3.3V , +5.0V Supply Voltages
- Voltage control (Electronic Frequency Tuning) is standard .



General Specifications (at+25°C and specified input voltage)

Output Waveform		Square wave. Waveform code is " T "		True Sine Wave. Waveform code is " E "	
Supply Voltage		+3.3 V	+5.0 V	+3.3 V	+5.0 V
Supply Voltage range , " Voltage code "		+3.3V ± 5% , " 3 "	+5.0V ± 5% , " 5 "	+3.3V ± 5% , " 3 "	+5.0V ± 5% , " 5 "
Frequency Range		5 ~ 40.0 MHz Standard Frequency : 10.0 MHz		5 ~ 40.0 MHz Standard Frequency : 10.0 MHz	
Initial Calibration Tolerance		± 100 ppb (max.)	± 100 ppb (max.)	± 100 ppb (max.)	± 100 ppb (max.)
		Vcon = +1.65 V	Vcon = +2.5 V	Vcon = +1.65 V	Vcon = +2.5 V
Type of Crystal Cut Used		" SC - cut " crystal or " IT - cut " crystal			
Frequency Stability	vs Temperature (refer to +25°C)	± 3 ppb (max.) over 0°C to +70°C			
		± 5.0 ppb (max.) over -30°C to +70°C			
		± 10 ppb (max.) over -40°C to +85°C			
	vs Voltage Change	± 0.5ppb (max.) , for a ± 5% input voltage change .			
	vs Warm-up time (+25°C)	10 minute max. Within ± 10 ppb of its reference frequency.			
	vs Aging	± 0.5 ppb max./after 30 days ; ± 50 ppb max./first year ; ± 300 ppb max.over 10 years.			
Voltage Control On pin 1 (EFC)	Freq. Deviation Range	± 0.5 ppm min. , ± 2 ppm max. Reference to fo at +25°C and over operating temperature range.			
	Control Voltage Range	+1.65V ± 1.65V		+2.5V ± 2.5V	
	Transfer Function	Positive : Increasing control voltage increases output frequency .			
(Electronic Freq. Tuning)	Input Impedance	50 K ohms min.			
	EFC Linearity	± 10 % (max.)			
Power	Power Dissipation (at +25°C)	1.3 Watts max. at steady-state; 850 mA max. at turn-on.			
	Output	Output Level (for True Sine)	---	---	+8 dBm (typ.) , +10 dBm (max.)
	Harmonic (for True Sine)	---	---	-30 dBc (min.)	
	Spurious (for True Sine)	---	---	-60 dBc (min.)	
	Load	15pF		50 Ω	
	Output Logic High (V _{OH})	+2.4 V (min.)	+2.4 V (min.)	---	---
	Output Logic Low (V _{OL})	+ 0.4 V (max.)	+ 0.4 V (max.)	---	---
	Duty Cycle (V _{DD})	50 % ± 5% @ +1.4V			
	Rise and Fall Time	7 nsec. (max.) (20% → 80% of waveform)			
	Phase Noise Offset [10.0 MHz] (typical)	10 Hz	100 Hz	1 KHz	10 KHz
		-120 dBc	-135 dBc	-145 dBc	-150 dBc

Outline Dimensions (Unit : ±0.2 mm)

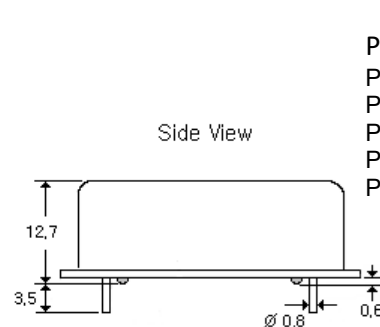
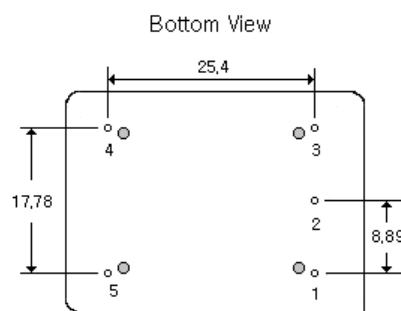
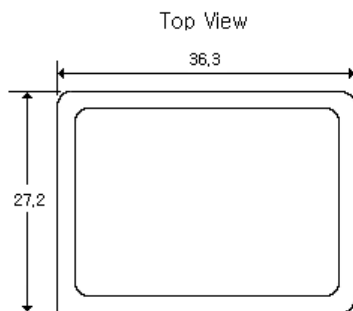

Pin Connections :
 Pin 1 : Voltage Control
 Pin 2 : Not Connected
 Pin 3 : V_{DD}
 Pin 4 : Output
 Pin 5 : Ground

OCXOs

" OCXO " [Oven Controlled Crystal Oscillators]

OC41T
Square Wave

Best stability
± 30 ppb

Standard
OCXO Series

SMD

3.3V

Min.
5 MHz

Max.
40 MHz

Applications

- OC41_ (14.5 * 9.6 * 6.5 mm)
- 6 pin SMD package
- +3.3V Supply Voltages
- Voltage control (Electronic Frequency Tuning) is standard .



General Specifications (at+25°C and specified input voltage)

Output Waveform		Square wave . Waveform code is " T "			
Supply Voltage		+3.3 V			
Supply Voltage range , " Voltage code "		+3.3V ± 5% , " 3 "			
Frequency Range		5 ~ 40.0 MHz			
Initial Calibration Tolerance		Vcon = +1.65 V ; ± 500 ppb (max.) typ. , ± 200 ppb (max.) available			
Type of Crystal Cut Used		" IT - cut " crystal			
Frequency Stability	vs Temperature (refer to +25°C)	± 20 ppb (max.) over -20°C to +70°C ± 30 ppb (max.) over -40°C to +85°C			
	vs Voltage Change	± 10 ppb (max.) , for a ± 5% input voltage change .			
	vs Warm-up time (+25°C)	5 minute max. Within ± 100 ppb of its reference frequency.			
	vs Aging	± 3.0 ppb max./after 30 days ; ± 400 ppb max./first year ; ± 2 ppm max. over 10 years.			
	vs Load Change	≤ ± 10 ppb , for ±10 % load condition change .			
	vs Reflow	± 1.0 ppm max. , 1 reflow and measured 24 hours afterwards.			
Voltage Control On pin 1 (EFC)	Freq. Deviation Range	> ± 5 ppm Reference to fo at +25°C and over operating temperature range.			
	Control Voltage Range	+1.65V ± 1.65V			
(Electronic Freq. Tuning)	Transfer Function	Positive : Increasing control voltage increases output frequency .			
	Input Impedance	50 K ohms min.			
	EFC Linearity	± 10 % (max.)			
Power	Power Dissipation (at +25°C)	0.6 Watts max. at steady-state; 600 mA max. at turn-on.			
Output	Output Logic High (V _{OH})	+ 2.4 V (min.)			
	Output Logic Low (V _{OL})	+0.4 V (max.)			
	Duty Cycle (V _{DD})	50 % ± 5% @ 1.65V			
	Load	15pF			
	Rise and Fall Time	7 nS (max.) (20% → 80% of waveform)			
	Phase Noise Offset [20.0 MHz] (typical)	10 Hz	100 Hz	1 KHz	10 KHz
	-98 dBc	-126 dBc	-145 dBc	-152 dBc	

Outline Dimensions (Unit : ±0.2 mm)

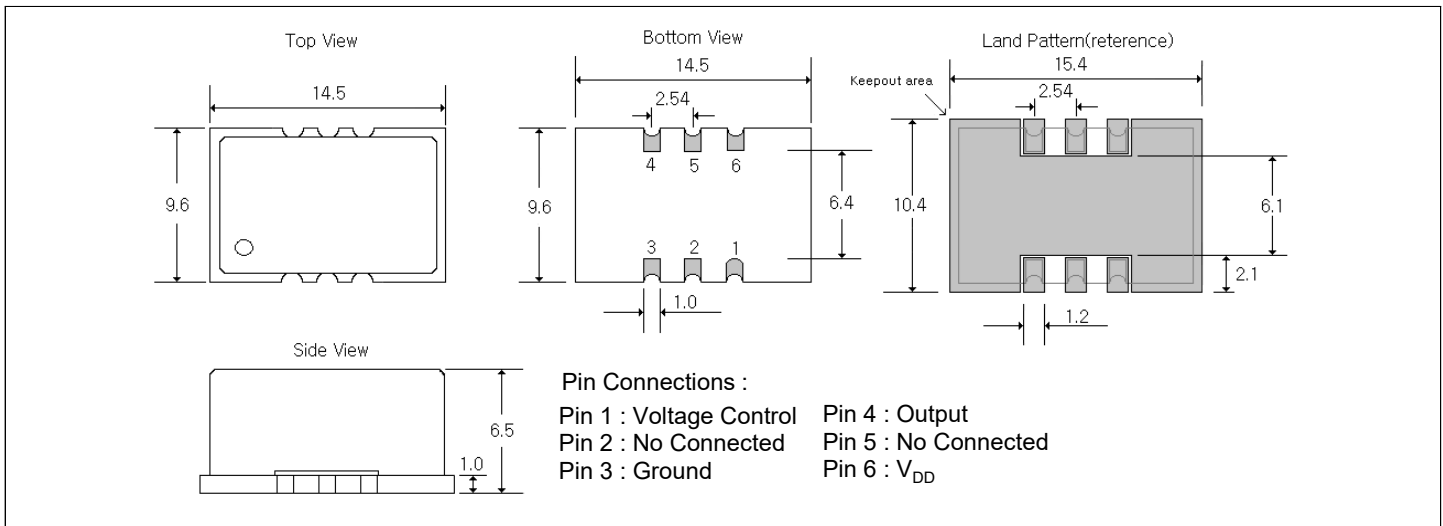

" OCXO " [Oven Controlled Crystal Oscillators]

OC51T

Square Wave

OC51S

Clipped Sine Wave

Best stability
± 20 ppb

Standard
OCXO Series

SMD

3.3V

5.0V

Min.
10 MHz

Max.
40 MHz

Applications

- OC51_ (9.7 x 7.5 x 4.1 mm) Miniaturized 4-Pad SMD package
- +3.3V , +5.0V Supply Voltages
- Voltage control (Electronic Frequency Tuning) is standard .

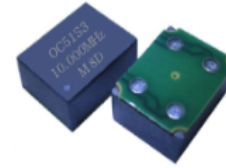

General Specifications (at+25°C and specified input voltage)

Output Waveform		Square wave. Waveform code is " T "		Clipped Sine Wave. Waveform code is " S "	
Supply Voltage		+3.3 V	+5.0 V	+3.3 V	+5.0 V
Supply Voltage range , " Voltage code "		+3.3V ± 5% , " 3 "	+5.0V ± 5% , " 5 "	+3.3V ± 5% , " 3 "	+5.0V ± 5% , " 5 "
Frequency Range		10 ~ 40.0 MHz		10 ~ 40.0 MHz	
Initial Calibration Tolerance		± 500 ppb (max.)		± 500 ppb (max.)	
		Vcon = +1.65 V	Vcon = +2.5 V	Vcon = +1.65 V	Vcon = +2.5 V
Type of Crystal Cut Used		" IT - cut " crystal			
Frequency Stability	vs Temperature (refer to +25°C)	± 10 ppb (max.) over -30°C to +70°C ± 20 ppb (max.) over -40°C to +85°C			
	vs Voltage Change	± 10ppb (max.) , for a ± 5% input voltage change .			
	vs Warm-up time (+25°C)	5 minute max. Within ± 0.1 ppm of its reference frequency.			
	vs Aging	± 3.0 ppb max./after 30 days ; ± 600 ppb max./first year ; ± 3 ppm max. over 10 years.			
	vs Reflow	± 1.0 ppm max . , 1 reflow and measured 24 hours afterwards.			
Voltage Control On pin 1 (EFC) (Electronic Freq. Tuning)	Freq. Deviation Range	> ± 5 ppm Reference to fo at +25°C and over operating temperature range.			
	Control Voltage Range	+1.65V ± 1.65V		+2.5V ± 2.5V	
	Transfer Function	Positive : Increasing control voltage increases output frequency .			
	Input Impedance	100 K ohms min.			
	EFC Linearity	± 10 % (max.)			
Power	Power Dissipation (at +25°C)	0.4 Watts max. at steady-state; 350 mA max. at turn-on.			
Output	Output Logic High (V _{OH})	+2.4 V (min.)	+4.5 V (min.)	-	-
	Output Logic Low (V _{OL})	+ 0.4 V (max.)	+ 0.4 V (max.)	-	-
	Duty Cycle (V _{DD})	50 % ± 5% @ 1.65V		-	
	Load	15pF		10 KΩ // 10 pF ± 10%	
	Output Voltage Level (peak to peak)	-		0.8 V p-p (min.)	
	Rise and Fall Time	7 nS (max.) (20% → 80% of waveform)			
	Phase Noise Offset [20.0 MHz] (typical)	10 Hz	100 Hz	1 KHz	10 KHz
	-98 dBc	-126 dBc	-145 dBc	-152 dBc	

Outline Dimensions (Unit : ±0.2 mm)

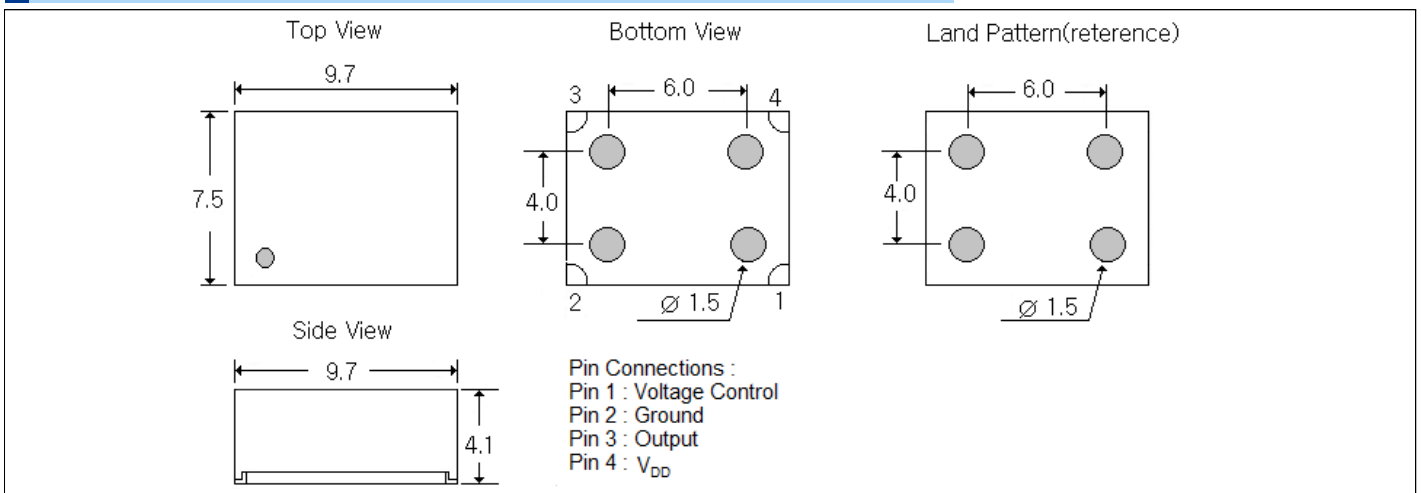

OCXOs

" OCXO " [Oven Controlled Crystal Oscillators]

Square Wave " OC _ T "

Clipped Sine Wave " OC _ S "

True Sine Wave " OC _ E "

Part Number Format and Example

	[1]	[2]	[3]	-	[4]	-	[5]	/	[6]
	Holder Type	Output Wave	Supply Voltage		Center Frequency		Frequency Stability		Operating Temp. Range
Examples	(1)	OC14	T	-	5.000	-	10	/	-40+85
	(2)	OC18	E	-	100.000	-	100	/	-30+70
	(3)	OC51	S	-	10.000	-	30	/	-20+70
	(4)	OC12	E	-	10.000	-	200	/	0+70

- Ex (1): OC14T5 - 5.000 - 10 / -40+85 [OC14 type , Square Wave , 5.0V , 5.000MHz , ± 10ppb from -40°C to 85°C]
 Ex (2): OC18E5 - 100.000 - 100 / -30+70 [OC18 type , True Sine Wave , 5.0V , 100.000MHz , ± 100ppb from -30°C to 70°C]
 Ex (3): OC51S3 - 10.000 - 30 / -20+70 [OC51 type , Clipped Sine Wave , 3.3V , 10.000MHz , ± 30ppb from -20°C to 70°C]
 Ex (4): OC12E3 - 10.000 - 200 / 0+70 [OC12 type , True Sine Wave , 3.3V , 10.000MHz , ± 200ppb from 0°C to 70°C]

[1]	Holder Type " OC__ " stands for OCXO ,
[2]	" T " stands for Square Wave , " E " stands for True Sine Wave , " S " stands for Clipped Sine Wave ex 1 : OC14T , OC14 package , Square Wave ; ex 2 : OC18E , OC18 package , True Sine Wave ; ex 3 : OC51S , OC51 package , Clipped Sine Wave ; ex 4 : OC12E , OC12 package , True Sine Wave
[3]	Supply voltage , " 5 " for 5.0V D.C , " 3 " for 3.3V D.C
[4]	Center Frequency in MHz
[5]	Frequency stability in ± __ ppb ; ex 1 : ± 10ppb ---10 , ex 2 : ± 100ppb ---100 , ex 3 : ± 30ppb ---30 , ex 4 : ± 200ppb ---200
[6]	Operating temperature range in °C ex 1 : -40 °C to 85°C ----- -40+85 ; ex 2 : -30 °C to 70°C ----- -30+70 ; ex 3 : -20 °C to 70°C ----- -20+70 ; ex 4 : 0 °C to 70°C ----- 0+70

SSB Phase Noise : Clipped Sine Wave(OC51S-20.000)

SSB Phase Noise : Square Wave(OC13T-10.000)

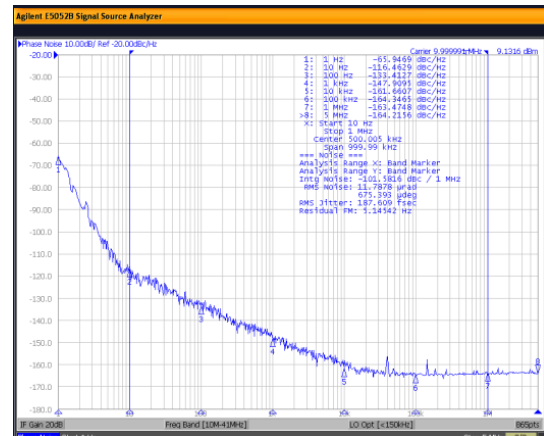
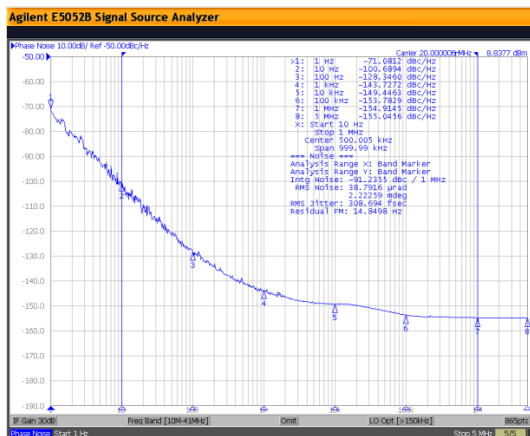

Aging : OC51S-20.000

Power Consumption vs Temperature (OC13T5-10.000)

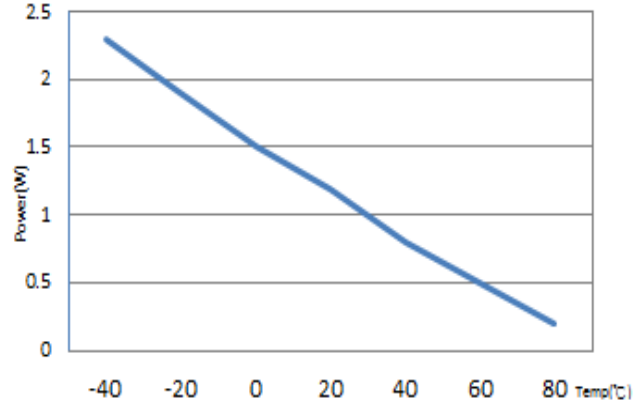
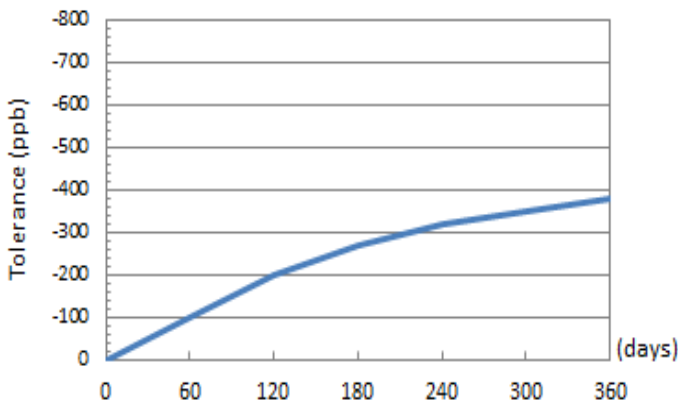

M.C.F. (Monolithic Crystal Filters) features high quality quartz resonators with sharp cutoff characteristics, low loss , good inter-modulation and a high stability over a wide temperature range . Consider applying band pass filters to communication systems .

Characteristic diagram and terms of crystal filters

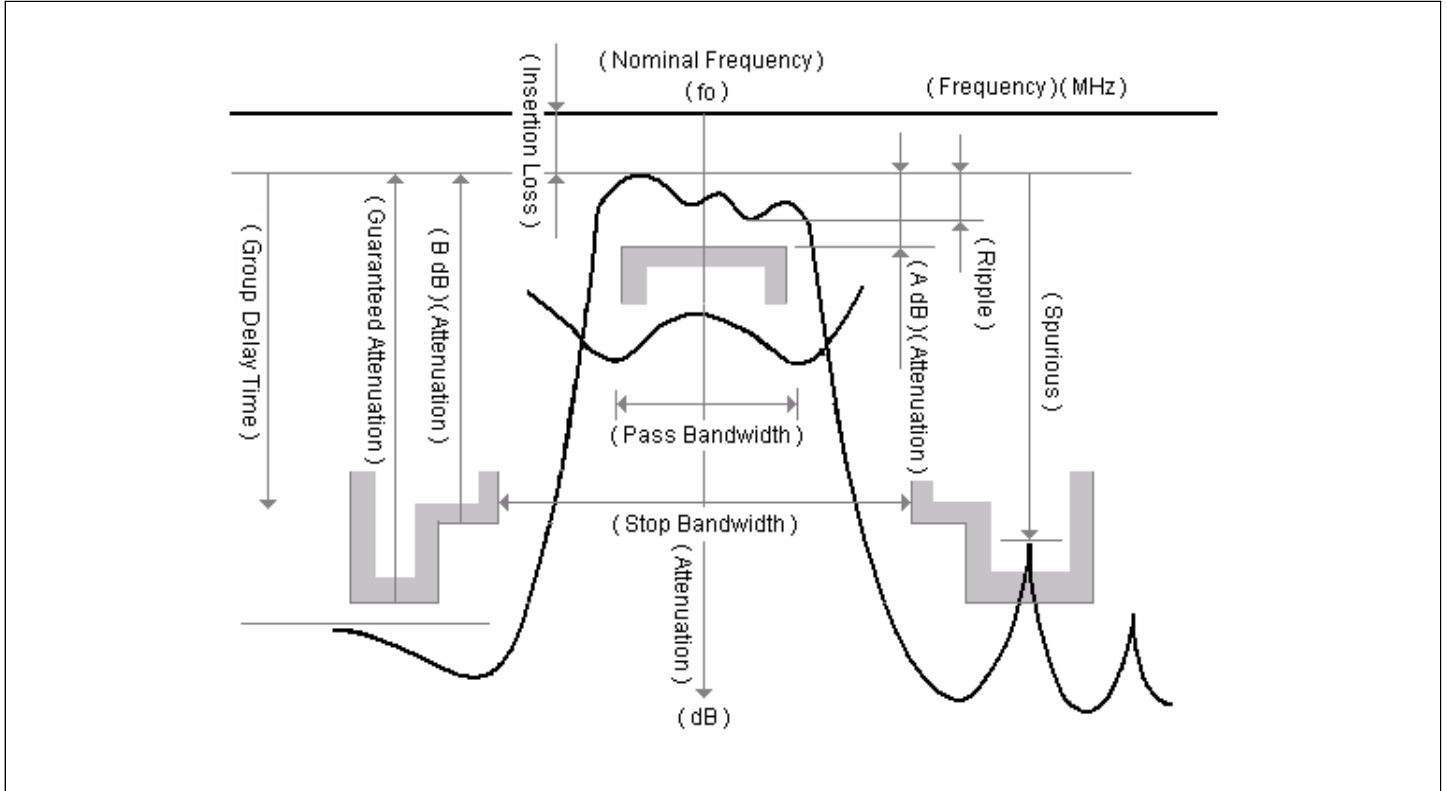

● Nominal Frequency :	This is the nominal value of the center frequency (f_0) and is used as the reference frequency of related standards.
● Pass Bandwidth :	This is the frequency interval in which the relative attenuation (the attenuation from the minimum insertion loss) is equal to the specified value "A dB" (Usually 3dB).
● Insertion Loss :	This is the difference of attenuation when a filter is and isn't inserted. The minimum insertion loss is the minimum value of insertion loss and becomes as the reference level of attenuation characteristics specification. The constant loss is the insertion loss at the nominal frequency.
● Ripple :	This is the maximum value of the difference between the peak value of attenuation in the pass band and the minimum insertion loss.
● Stop Bandwidth :	This is the frequency interval in which the relative attenuation is equal to the specified value "B dB".
● Guaranteed Attenuation :	This is the relative attenuation guaranteed in the specified range within attenuation band scope.
● Spurious Response :	This is the value of relative attenuation generated by the secondary vibration in the specified range within attenuation band scope.
● Group Delay Time :	This is the difference between the maximum and the minimum value of the group delay in the specified range of the pass band.
● Terminating Impedance :	This is the impedance value terminated to the input and the output side of filter and is indicated by the resistance portion and the parallel capacity portion including the floating capacity.

MQ
7.0 * 5.0 * 1.3 mm

Surface Mount
4 poles in one package

Fund.

21.4
MHz

21.7
MHz

45.0
MHz

50.85
MHz

2 poles
4 poles

Features

- Specifically designed for mobile, wireless communications pagers, cellular and cordless phones.

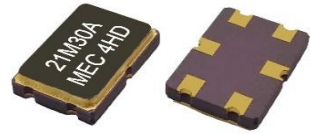

Surface Mount Type [MQ series (21.400 , 21.700 , 45.000 , 50.850 MHz)]

Frequency (MHz)	Model	No. of poles	Pass Bandwidth		Stop Bandwidth		Ripple	Insertion Loss	Guaranteed Attenuation		Terminating Impedance	
			dB	KHz (min.)	dB	KHz (max.)	dB (max.)	dB (max.)	dB	KHz	ohms // pF	Cc (pF)
21.400	21MQ7.5A	2	3	± 3.75	20	± 18	1.0	2.0	70	-910	850 // 6.0	
	21MQ15A	2	3	± 7.5	18	± 25	0.5	1.5	70	-910	1500 // 2.5	
	21MQ15B	4	3	± 7.5	40	± 25	1.0	3.0	70	-910	1800 // 0.35	5.0
	21MQ30A	2	3	± 15	15	± 50	1.5	2.0	60	-910	2500 // 0	
21.700	21.7MQ15A	2	3	± 7.5	18	± 28	1.0	2.0	70	-910	1500 // 2.5	
45.000	45MQ7.5A	2	3	± 3.75	15	± 18	1.0	2.0	70	-910	350 // 6.0	
	45MQ7.5B	4	3	± 3.75	40	± 15	1.0	4.0	80	-910	300 // 5.0	16.0
	45MQ15A	2	3	± 7.5	15	± 25	1.0	2.0	70	-910	560 // 6.0	
	45MQ15B	4	3	± 7.5	30	± 25	1.0	3.0	80	-910	800 // 1.7	8.0
50.850	50.85MQ15B	4	3	± 7.5	35	± 25	1.0	3.0	80	-910	620 // 0.5	5.0

(Operating Temperature Range : -20°C to +70°C ; Storage Temperature Range : -40°C to +85°C)

Part Number Format and Example

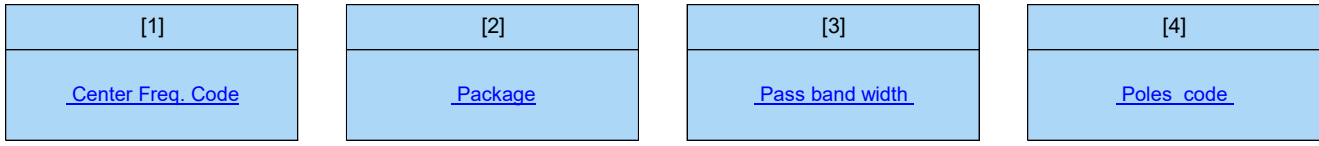

Ex (1) : **45MQ15B** [45.000 MHz , SMD Type package , Pass band width ± 7.5KHz , 4 poles]

[1]	Center freq. code : " 21 " for 21.400MHz , " 21.7 " for 21.700MHz , " 45 " for 45.000MHz , " 50.85 " for 50.850MHz
[2]	" MQ " series for (7.0 * 5.0 * 1.3mm) SMD Type package
[3]	Pass band width (3dB) (min.) [" 7.5 " for ± 3.75 KHz , " 15 " for ± 7.5 KHz , " 30 " for ± 15 KHz]
[4]	Poles code [" A " for 2 poles] [" B " for 4 poles]

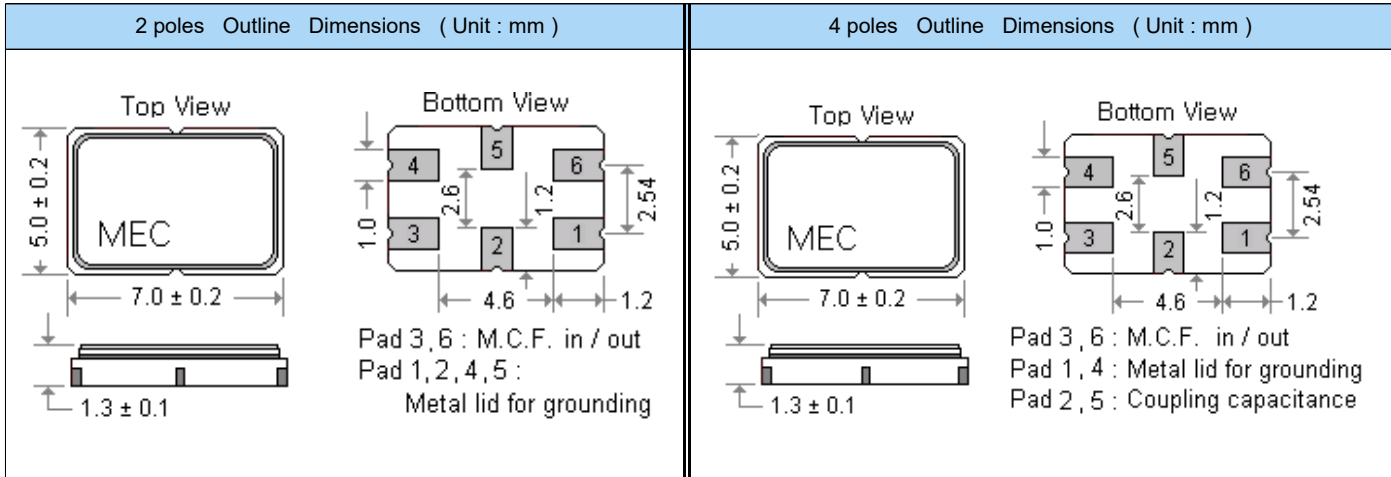

49T

[11.5 * 4.5 * 11.2 mm]

Dip Type

Fundamental

10.7 MHz

2 poles

4 poles

6 poles

8 poles

Thru - Hole Type (standard frequency 10.700 MHz)

Channel Spacing (KHz)	Model	No. of poles	Pass Bandwidth		Stop Bandwidth		Ripple dB (max.)	Insertion Loss dB (max.)	Guaranteed Attenuation		Terminating Impedance ohms // pF	Package	
			dB	KHz (min.)	dB	KHz (max.)			dB	KHz		Tandem set	One package
12.5	10M7.5A	2	3	± 3.75	20	± 18	0.5	1.5	35	±300 ~ ±1000	1.8K // 5.0	49T	
	10M7.5B	4	3	± 3.75	40	± 14	1.0	2.5	65	±300 ~ ±1000	1.8K // 4.5	49T a pair	
	10M7.5C	6	3	± 3.75	45	± 8.75	2.0	3.5	65	±12.5 ~ ±300	1.8K // 3.5	49T 3 pcs	L1
	10M7.5D	8	3	± 3.75	65	± 8.75	2.0	4.0	90	±12.5 ~ ±300	1.8K // 3.5	49T 4 pcs	L2
20.0	10M12A	2	3	± 6.0	18	± 25	0.5	2.0	35	±300 ~ ±1000	2.5K // 2.5	49T	
	10M12B	4	3	± 6.0	40	± 20	1.0	2.5	65	±300 ~ ±1000	2.5K // 1.5	49T a pair	
	10M12C	6	3	± 6.0	45	± 15	2.0	4.0	65	±20 ~ ±300	2.5K // 1.5	49T 3 pcs	L1
	10M12D	8	3	± 6.0	65	± 15	2.0	2.0	90	±20 ~ ±300	2.5K // 1.5	49T 4 pcs	L2
25.0	10M15A	2	3	± 7.5	18	± 25	0.5	1.5	35	±300 ~ ±1000	3.0K // 2.0	49T	
	10M15B	4	3	± 7.5	40	± 25	1.0	2.5	55	±300 ~ ±1000	3.0K // 1.5	49T a pair	
	10M15C	6	3	± 7.5	45	± 18	2.0	3.0	65	±25 ~ ±300	3.3K // 1.5	49T 3 pcs	L1
	10M15D	8	3	± 7.5	65	± 18	2.0	4.0	90	±25 ~ ±300	3.3K // 1.5	49T 4 pcs	L2
50.0	10M30A	2	3	± 15	15	± 50	0.5	1.5	30	±300 ~ ±1000	5.0K // 0	49T	
	10M30B	4	3	± 15	30	± 40	1.0	2.5	30	±300 ~ ±1000	5.5K // -1.0	49T a pair	
	10M30C	6	3	± 15	60	± 45	2.0	3.0	65	±45 ~ ±300	5.5K // -1.0	49T 3 pcs	L1
	10M30D	8	3	± 15	60	± 30	2.0	3.5	90	±50 ~ ±300	5.5K // -1.0	49T 4 pcs	L2

Part Number Format and Example

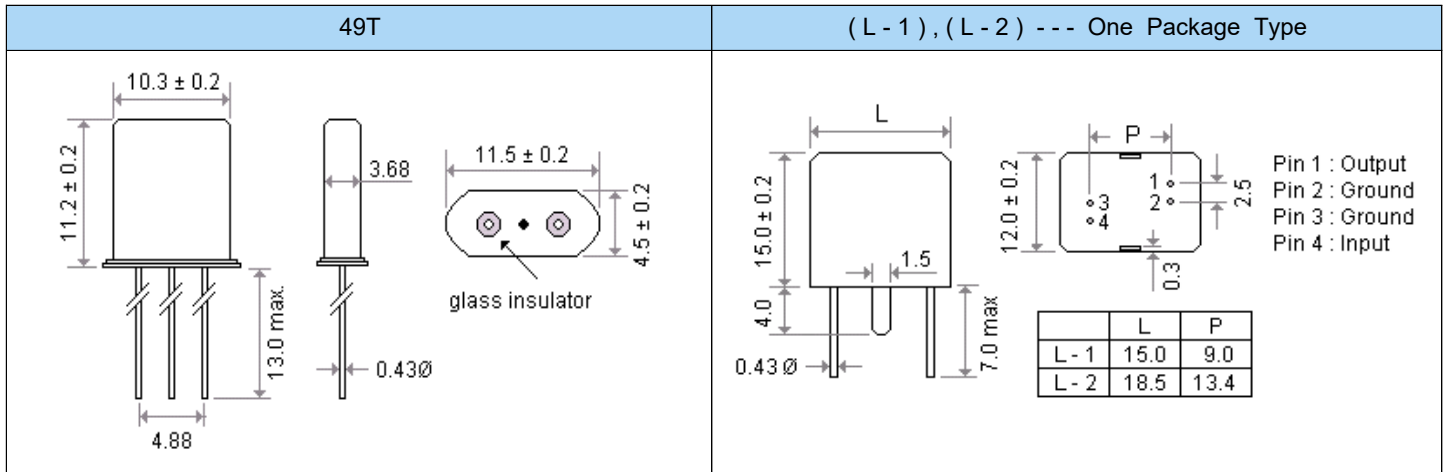

4 pole M.C.F. (Paired packages , Tandem set)

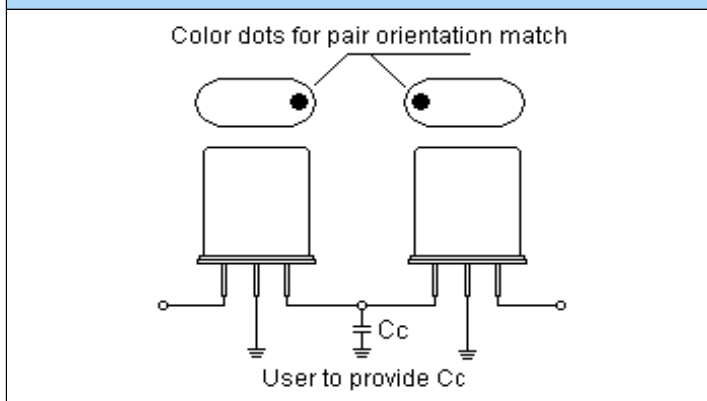

M. C. F. [Monolithic Crystal Filters]

U1

[7.8 * 3.1 * 8.0 mm]

U5

[7.8 * 3.1 * 6.0 mm]

Dip Type

Fund.

21.4 MHz

45.0 MHz

2 poles

4 poles

6 poles

8 poles

Thru - Hole Type (standard frequency 21.400 MHz)

Channel Spacing (KHz)	Model	No. of poles	Pass Bandwidth		Stop Bandwidth		Ripple	Insertion Loss	Guaranteed Attenuation		Terminating Impedance	Package	
			dB	KHz (min.)	dB	KHz (max.)	dB (max.)	dB (max.)	dB	KHz	ohms // pF	Tandem set	One package
12.5	21M7.5A	2	3	± 3.75	20	± 18	0.5	1.5	35	±300 ~ ±1000	850 // 6.0	U-1 , U-5	
	21M7.5B	4	3	± 3.75	40	± 15	1.0	2.5	65	±300 ~ ±1000	850 // 5.0	a pair (U -1,U-5)	
	21M7.5C	6	3	± 3.75	45	± 8.75	2.0	3.0	65	±12.5 ~ ±300	850 // 5.0	3 pcs	S1
	21M7.5D	8	3	± 3.75	65	± 8.75	2.0	4.0	90	±12.5 ~ ±300	850 // 5.0	4 pcs	S2
20.0	21M12A	2	3	± 6.0	20	± 25	0.5	1.5	35	±300 ~ ±1000	1.2K // 3.0	U-1 , U-5	
	21M12B	4	3	± 6.0	40	± 20	1.0	2.5	65	±300 ~ ±1000	1.2K // 2.5	a pair (U -1,U-5)	
	21M12C	6	3	± 6.0	45	± 15	2.0	3.0	65	±20 ~ ±300	1.2K // 2.5	3 pcs	S1
	21M12D	8	3	± 6.0	65	± 15	2.0	4.0	90	±20 ~ ±300	1.2K // 2.5	4 pcs	S2
25.0	21M15A	2	3	± 7.5	18	± 25	0.5	1.5	35	±300 ~ ±1000	1.5K // 2.0	U-1 , U-5	
	21M15B	4	3	± 7.5	40	± 25	1.0	2.5	65	±300 ~ ±1000	1.5K // 2.0	a pair (U -1,U-5)	
	21M15C	6	3	± 7.5	45	± 18	2.0	3.0	65	±25 ~ ±300	1.5K // 2.0	3 pcs	S1
	21M15D	8	3	± 7.5	65	± 18	2.0	4.0	90	±25 ~ ±300	1.5K // 2.0	4 pcs	S2
50.0	21M30A	2	3	± 15	15	± 45	0.5	1.5	35	±300 ~ ±1000	1.5K // 1.0	U-1 , U-5	
	21M30B	4	3	± 15	40	± 50	1.0	2.5	65	±300 ~ ±1000	2.2K // 0.5	a pair (U -1,U-5)	
	21M30C	6	3	± 15	45	± 35	2.0	3.0	65	±45 ~ ±300	2.2K // 0.5	3 pcs	S1
	21M30D	8	3	± 15	65	± 35	2.0	4.0	90	±50 ~ ±300	2.2K // 0.5	4 pcs	S2

Thru - Hole Type [standard frequency 45.000 MHz(Fundamental mode)] ; available frequency range (45.000 ~ 45.100 MHz)

Channel Spacing (KHz)	Model	No. of poles	Pass Bandwidth		Stop Bandwidth		Ripple	Insertion Loss	Guaranteed Attenuation		Terminating Impedance	Package	
			dB	KHz (min.)	dB	KHz (max.)	dB (max.)	dB (max.)	dB	KHz	ohms // pF	Type	
12.5	45M7.5A	2	3	± 3.75	10	± 12.5	1.0	2.0	65	±300 ~ ±1000	200 // 4.0	U5	U1
	45M7.5B	4	3	± 3.75	30	± 12.5	1.0	4.0	80	±300 ~ ±1000	350 // 6.5	U5 a pair	U1 a pair
25.0	45M15A	2	3	± 7.5	15	± 25	1.0	2.0	35	±300 ~ ±1000	650 // 3.0	U5	U1
	45M15B	4	3	± 7.5	30	± 25	1.0	3.0	80	±300 ~ ±1000	650 // 3.0	U5 a pair	U1 a pair
50.0	45M30A	2	3	± 15	15	± 60	1.5	2.5	35	±300 ~ ±1000	1.2K // 0	U5	U1
	45M30B	4	3	± 15	30	± 50	1.0	3.0	80	±300 ~ ±1000	1.2K // 0.7	U5 a pair	U1 a pair

Part Number Format and Example

Dip Type Part Number Format				
[1]	[2]	[3]	[4]	[5]
Frequency Code	M	Width Code	Poles Code	Holder Type

Examples	21	M	15	D	U5
----------	----	---	----	---	----

[1]	Freq. code : " 10 " for 10.700MHz , " 21 " for 21.400MHz , " 45 " for 45.000MHz , " 50.85 " for 50.850MHz Freq. code : If none standard freq. please show frequency with one decimal point .
[2]	" M " Dip Type series ,
[3]	Pass band width (3dB) (min.) " 7.5 " for ± 3.75 KHz , " 12 " for ± 6.0 KHz , " 15 " for ± 7.5 KHz , " 30 " for ± 15 KHz ,
[4]	No. of poles " A " for 2 poles , " B " for 4 poles , " C " for 6 poles , " D " for 8 poles
[5]	Dip type holder type
[6]	Standard operating temperature range is -20°C to 70°C , If non-standard please enter the desired temp. range after " / " , for example " / -30+70 " : -30°C to 70°C

Package Dimensions (unit : mm)

[U 1]	[U 5]									
4 pole M.C.F. (Paired packages , Tandem set)	[S - 1] , [S - 2]									
<p>Color dots for pair orientation match</p> <p>User to provide Cc</p>	<table border="1" style="margin-left: auto; margin-right: auto;"> <thead> <tr> <th></th> <th>L</th> <th>P</th> </tr> </thead> <tbody> <tr> <td>S - 1</td> <td>11.0</td> <td>7.4</td> </tr> <tr> <td>S - 2</td> <td>13.4</td> <td>9.8</td> </tr> </tbody> </table> <p>Pin 1 : Output Pin 2 : Ground Pin 3 : Ground Pin 4 : Input</p>		L	P	S - 1	11.0	7.4	S - 2	13.4	9.8
	L	P								
S - 1	11.0	7.4								
S - 2	13.4	9.8								

Part Number Formats and Product Marking Rules

Quartz Crystals

Holder Type

SMD type : X11 X21 X22 X32 MJ MQ M49 ML49 MP5 MP4 MP25 MP24
X2012 X3215
 Dip type : H49 HUS HUSL U1 U5 T38 T26

Part Number Format and Example

	[1] Holder Type	-	[2] Center Freq.	-	[3] CL	-	[4] Freq. Tolerance	/	[5] Freq. Stability	[6] Operating Temp. Range Code	/	[7] Special ESR
Example	(1)	H49	40.000A3	12	30	/	30	X				
	(2)	X32	26.000	16	30	/	30	X			/	20R
	(3)	MJ	12.000	20	10	/	10	W				
	(4)	M49	24.000	18	20	/	30	H			/	15R

Ex (1) : H49 - 40.000A3 - 12 - 30 / 30 X [49/U type, 40.000MHz, AT-cut 3rd overtone, 12pF, ±30ppm (25°C), ±30ppm (-10°C to 60°C)]
 Ex (2) : X32 - 26.000 - 16 - 30 / 30 X / 20R [X32 type, 26.000MHz, 16pF, ±30ppm (25°C), ±30ppm (-10°C to 60°C), 20 Ω]
 Ex (3) : MJ - 12.000 - 20 - 10 / 10 W [MJ type, 12.000MHz, 20pF, ±10ppm (25°C), ±10ppm (0°C to 50°C)]
 Ex (4) : M49 - 24.000 - 18 - 20 / 30 H / 15R [M49 type, 24.000MHz, 18pF, ±20ppm (25°C), ±30ppm (-30°C to 85°C), 15 Ω]

[1]	Holder Type																													
[2]	Center frequency . Please add " A3 , A5 or B " after the " Freq. in MHz " for the quartz cut other options . Blank : AT-cut fund. mode ; A3 : AT-cut 3rd overtone ; A5 : AT-cut 5th overtone ; B : BT-cut fund. mode ; SL : SL-cut fund. mode																													
[3]	Load Capacitance (CL) : series (spec. code is " S ") or Parallel (If parallel , please specify CL value , typical CL ranges from 8 to 32 pF) Available Options " V " = Vinyl sleeve around holder , " K " = 3rd lead at bottom center , " R " = On reel " G " = 3rd lead at top center , " I " = Teflon insulator at bottom																													
[4]	Calibration tolerance value : freq. tolerance value (at 25°C) , industrial temp. range																													
[5]	Frequency Stability , industrial temp. range																													
[6]	Temp. Range Options																													
	<table border="1" style="width: 100%; border-collapse: collapse; text-align: center;"> <tr> <td>W</td><td>0°C ~ +50°C</td> <td>X</td><td>-10°C ~ +60°C</td> <td>Y</td><td>-20°C ~ +70°C</td> <td>F</td><td>-30°C ~ +70°C</td> <td>G</td><td>-10°C ~ +80°C</td> </tr> <tr> <td>H</td><td>-30°C ~ +85°C</td> <td>I</td><td>-40°C ~ +85°C</td> <td>J</td><td>-40°C ~ +90°C</td> <td>K</td><td>-40°C ~ +105°C</td> <td>M</td><td>-55°C ~ +105°C</td> </tr> <tr> <td>N</td><td>-55°C ~ +125°C</td> <td></td><td></td> <td></td><td></td> <td></td><td></td> <td></td> </tr> </table> Temp. Range is -10°C to 60°C , for example " X "	W	0°C ~ +50°C	X	-10°C ~ +60°C	Y	-20°C ~ +70°C	F	-30°C ~ +70°C	G	-10°C ~ +80°C	H	-30°C ~ +85°C	I	-40°C ~ +85°C	J	-40°C ~ +90°C	K	-40°C ~ +105°C	M	-55°C ~ +105°C	N	-55°C ~ +125°C							
W	0°C ~ +50°C	X	-10°C ~ +60°C	Y	-20°C ~ +70°C	F	-30°C ~ +70°C	G	-10°C ~ +80°C																					
H	-30°C ~ +85°C	I	-40°C ~ +85°C	J	-40°C ~ +90°C	K	-40°C ~ +105°C	M	-55°C ~ +105°C																					
N	-55°C ~ +125°C																													
[7]	If non-standard please enter the desired Temp. Range after " / " , for example " -20 + 60 " : -20°C to 60°C If non-standard please enter the desired ESR (Equivalent Series Resistance) after " / " , for example " 20R " : 20Ω																													

Production Marking Rules

General X'tal package type marking rules	MQ, MJ marking rules	X22, X32 marking rules
<p>(Cutting method) : A : AT-cut (fundamental) B : BT-cut (fundamental) 3 : AT-cut (3rd overtone) 5 : AT-cut (5th overtone) SL : SL-cut (fundamental)</p> <p>Lot code (month) : Table 2 (Year) : ex: 2024 - 4 Load capacitance (CL) : Table 1</p>	<p>(Cutting method) : A : AT-cut , fundamental B : BT-cut , fundamental 3 : AT-cut , 3rd overtone 5 : AT-cut , 5rd overtone</p>	<p>X21 marking rules</p>

Table 1	CL	< 10	10	11	12	13	14	15	16	17	18	19	20	21	22	23	24	25	26	27	28	29	30	31	32	33	34	>34	Series
	Code	A	B	C	D	E	F	G	H	I	J	K	L	M	N	O	P	Q	R	S	T	U	V	W	X	Y	Z	a	b
Table 2	Month	Jan.	Feb.	Mar.	Apr.	May	Jun.	Jul.	Aug.	Sep.	Oct.	Nov.	Dec.																
	Code	A	B	C	D	E	F	G	H	I	J	K	L																

Part Number Formats and Product Marking Rules

Crystal Oscillators

Holder Type

Output Wave Output Logic	Supply Voltage	Product Series	SMD types
Square Wave LVPECL	2.5 / 3.3	HPK x x x	x x x = 576 , 536 , 326 , 226
	3.3	HPEK x x x	x x x = 576 , 536 , 326 , 226
	2.5 / 3.3	HPJK x x x	x x x = 576 , 536 , 326 , 226
	2.5 / 3.3	HPQN x x x	x x x = 576 , 536 , 326
	2.5 / 3.3	HPQF x x x	x x x = 576 , 536 , 326
	2.5 / 3.3	HPRK x x x	x x x = 576 , 536 , 326 , 226
	2.5 / 3.3	HPJFN x x x	x x x = 578 , 538 , 328
	2.5 / 3.3	HCPQF x x x	x x x = 576 , 536 , 326
	2.5 / 3.3	HCPJFN x x x	x x x = 578
Square Wave LVDS	1.8 / 2.5 / 3.3	HDK x x x	x x x = 576 , 536 , 326 , 226
	2.5 / 3.3	HDEK x x x	x x x = 576 , 536 , 326 , 226
	1.8 / 2.5 / 3.3	HDJK x x x	x x x = 576 , 536 , 326 , 226
	2.5 / 3.3	HDQN x x x	x x x = 576 , 536 , 326
	2.5 / 3.3	HDQF x x x	x x x = 576 , 536 , 326
	1.8 / 2.5 / 3.3	HDRK x x x	x x x = 576 , 536 , 326 , 226
	1.8 / 2.5 / 3.3	HDJFN x x x	x x x = 578 , 538 , 328
	2.5 / 3.3	HCDQF x x x	x x x = 576 , 536 , 326
	1.8 / 2.5 / 3.3	HCDJFN x x x	x x x = 578
Square Wave HCSL	1.8 / 2.5 / 3.3	HCK x x x	x x x = 576 , 536 , 326 , 226
	2.5 / 3.3	HCEK x x x	x x x = 576 , 536 , 326 , 226
	1.8 / 2.5 / 3.3	HCJK x x x	x x x = 576 , 536 , 326 , 226
	2.5 / 3.3	HCRK x x x	x x x = 576 , 536 , 326 , 226
	1.8 / 2.5 / 3.3	HCJFN x x x	x x x = 578 , 538 , 328
	1.8 / 2.5 / 3.3	HCCJFN x x x	x x x = 578
Square Wave CML	1.8 / 2.5 / 3.3	HQJFN x x x	x x x = 578 , 538 , 328
	1.8 / 2.5 / 3.3	HCQJFN x x x	x x x = 578
Square Wave LPHCSL	1.8 / 2.5 / 3.3	HCLK x x x	x x x = 576 , 536 , 326 , 226

Output Wave Output Logic	Supply Voltage	Product Series	SMD types	Thru-Hole types
Square Wave CMOS	1.8 / 2.5 / 3.3 / 5.0	SWO	SWO	-----
	1.8 / 2.5 / 3.3 / 5.0	H x x	x x = 53 , 32 , 22 , 21	x x = 8,14
	1.8 / 2.5 / 3.3 / 5.0	HG x x	-----	
	1.8 / 2.5 / 3.3 / 5.0	HA x x	x x = 57 , 53 , 32 , 22	
	1.8 / 2.5 / 3.3	HEA x x	x x = 57 , 53 , 32 , 22	
	1.8 / 2.5 / 3.3	HJN x x	x x = 57 , 53 , 32 , 22	
	1.8 / 2.5 / 3.3	HY x x	x x = 57 , 53 , 32 , 22	
	1.0 / 1.2	HU x x	x x = 57 , 53 , 32 , 22	
	1.8 / 2.5 / 3.3	HTF x x	x x = 57 , 53 , 32 , 22 , 21	-----
	2.5 / 3.3	HTQN x x x	x x x = 576 , 536 , 326	
	2.5 / 3.3	HTQF x x x	x x x = 576 , 536 , 326	
	1.8 / 2.5 / 3.3	HTJFN x x x	x x x = 578 , 538	
	2.5 / 3.3	HCTQF x x x	x x x = 576 , 536 , 326	
1.8 / 2.5 / 3.3	HCTJFN x x x	x x x = 578		
Square Wave True Sine	3.3 / 5.0	HS x x	-----	x x = 14
	3.3 / 5.0	HS x x	-----	x x = 24

" x x x " = package code

Part Number Format and Example

	[1] Supply Voltage	[2] Holder Type	-	[3] Frequency Stability	[4] OE Function	-	[5] Center Frequency
EX.	(1) 25	H32	-	C20	T	-	100.000
	(2) 3	HDQN5761	-	E		-	156.250

Ex (1) : 25H32 - C20T - 100.000 [2.5V , H32 type , OE on pin 1 , ±20ppm from -20°C to 70°C , 100.000MHz]

Ex (2) : 3HDQN5761 - E - 156.250 [3.3V , HDQN5761 type , OE on pin 1 , ±50ppm from -40°C to 85°C , 156.250MHz]

[1]	Supply voltage , " 10 " for +1.0V ; " 12 " for +1.2V ; " 18 " for +1.8V ; " 25 " for +2.5V ; " 28 " for +2.8V ; " 3 " for +3.3V ; " 5 " for +5.0V
[2]	Holder Type
[3]	-20°C ~ 70°C " A " ± 25ppm ; " B " ± 50ppm ; " C " ± 100ppm ; If non-standard please enter the desired stability after " C " , for example " C20 " : represents ±20ppm over -20 to +70°C
	-40°C ~ 85°C " D " ± 25ppm ; " E " ± 50ppm ; " F " ± 100ppm ; If non-standard please enter the desired stability after " F " , for example " F30 " : represents ±30ppm over -40 to +85°C
	-40°C ~ 105°C " G " ± 25ppm ; " H " ± 50ppm ; " J " ± 100ppm ; If non-standard please enter the desired stability after " J " , for example " J40 " : represents ±40ppm over -40 to +105°C
[4]	" T " for OE Function , Leave this space blank if no connection on pad 1.
[5]	Frequency in MHz

Part Number Formats and Product Marking Rules

Crystal Oscillators

Production Marking Rules

<p>H14 , H8</p>	<p>H (A , Y , U) 57 H (A , Y , U) 53</p>	<p>H (A , Y , U , EA , JN , TF) 32 H (A , Y , U , EA , JN , TF) 22</p>
<p>SWO , H53</p>	<p>H (EA , JN , TF) 57 , 53</p>	<p>H21 , HTF21</p>
<p>(H_K , H_JK , H_EK , H_RK) 5761 (H_QN , H_QF) 5761</p>	<p>(H_K , H_JK , H_EK , H_RK) 5361 (H_QN , H_QF) 5361</p>	<p>(H_K , H_JK , H_EK , H_RK) 3261 (H_K , H_JK , H_EK , H_RK) 2261</p>
<p>H_QN3261 , H_QF3261</p>	<p>H_JFN5781 , H_JFN5381</p>	<p>H_JFN3281</p>
<p>HC_QF5761 , HC_QF5361</p>	<p>HC_QF3261</p>	<p>HC_JFN578</p>

Table 1	-20°C ~ 70°C	" A " ± 25ppm ; " B " ± 50ppm ; " C " ± 100ppm ; If non-standard please enter the desired stability after " C " , for example " C20 " : represents ±20ppm over -20 to +70°C
	-40°C ~ 85°C	" D " ± 25ppm ; " E " ± 50ppm ; " F " ± 100ppm ; If non-standard please enter the desired stability after " F " , for example " F30 " : represents ±30ppm over -40 to +85°C
	-40°C ~ 105°C	" G " ± 25ppm ; " H " ± 50ppm ; " J " ± 100ppm ; If non-standard please enter the desired stability after " J " , for example " J40 " : represents ±40ppm over -40 to +105°C

Table 2	Month	1	2	3	4	5	6	7	8	9	10	11	12
	Code	A	B	C	D	E	F	G	H	I	J	K	L

Table 3	Supply Voltage	5.0 V	3.3 V	3.0 V	2.8 V	2.5 V	1.8 V	1.5 V	1.2 V	1.0 V	2.5~3.3 V
		B	D	E	F	H	J	L	N	P	W

Part Number Formats and Product Marking Rules

Spread Spectrum Low EMI Clock Oscillators

Holder Type

Type	SMD types	Waveform
HM x x	x x = 22 , 32 , 53 , 572	square wave

x x = package code

Part Number Format and Example

	[1]	[2]	-	[3]	[4]	-	[5]	[6]	-	[7]		
	Supply Voltage	Holder Type		Frequency Stability	OE Function		Center Frequency	Group Type		Spread type Percentage		
Examples	(1)	3		HM572	-	B	T	-	10.000	B	-	C1.5
	(2)	25		HM53	-	F	T	-	75.000	B	-	C2.0
	(3)	18		HM32	-	E	T	-	25.000	C	-	D1.0

Ex (1) : 3HM572 - BT - 10.000B - C1.5 [3.3V , HM572 type , ±50ppm from -20°C to 70°C , OE Function , 10.000MHz , B group , Center Spread 1.5%]

Ex (2) : 25HM53 - FT - 75.000B - C2.0 [2.5V , HM53 type , ±100ppm from -40°C to 85°C , OE Function , 75.000MHz , B group , Center Spread 2.0%]

Ex (3) : 18HM32 - ET - 25.000C - D1.0 [1.8V , HM32 type , ±50ppm from -40°C to 85°C , OE Function , 25.000MHz , C group , Down Spread 1.0%]

[1]	Supply Voltage , " 18 " for +1.8V ; " 25 " for +2.5V ; " 3 " for +3.3V
[2]	Holder Type (HM572 , HM53 , HM32)
[3]	-20°C ~ 70°C " A " ± 25ppm ; " B " ± 50ppm ; " C " ± 100ppm ;
	-40°C ~ 85°C " D " ± 25ppm ; " E " ± 50ppm ; " F " ± 100ppm ;
[4]	" T " for OE Function
[5]	Frequency in MHz
[6]	Group " B " , " C "
[7]	Spread type & percentage ; " C " for Center Spread , " D " for Down Spread

Production Marking Rules

HM22 , HM32	HM572 , HM53
<p>Hold Type ← Supply Voltage ← - Table 3 " D " +3.3V Pin # 1 indicator Frequency ex: 20 (20.0MHz) [Month]: Table 2 [Year]: 2020 - 0 ; 2021 - 1 Group Types : " C "</p>	<p>Hold Type (Dimensions) ← "HM572" = 7.0*5.0*1.4mm Supply Voltage ← " 3 " +3.3V ; " 25 " +2.5V Frequency ex: 10.000 (10.0MHz) Pin # 1 indicator Frequency Stability : Table 1 " T " for Tri-state Group Types " B " , " C " Part Number Suffix Vs Spread Type & Percentage [1] CO.5 (center spread ± 0.5%) [2] D2.0 (down spread ± 2.0%) lot code [Month]: Table 2 [Year]: 2020 - 0 ; 2021 - 1</p>

Table 1	-20°C ~ 70°C	" A " ± 25ppm ; " B " ± 50ppm ; " C " ± 100ppm ;
	-40°C ~ 85°C	" D " ± 25ppm ; " E " ± 50ppm ; " F " ± 100ppm ;

Table 2	Month	Jan.	Feb.	Mar.	Apr.	May	Jun.	Jul.	Aug.	Sep.	Oct.	Nov.	Dec.
	Code	A	B	C	D	E	F	G	H	I	J	K	L

Table 3	Supply	3.3 V	2.5 V	1.8 V
	Voltage	D	H	J

Part Number Formats and Product Marking Rules

[VCXO] Voltage Controlled Crystal Oscillators

Holder Type

Output Wave Output Logic	Supply Voltage	Product Series	SMD types
Square Wave LVPECL	2.5 / 3.3	GPQN xxx	xxx = 576 , 536 , 326
	2.5 / 3.3	GPQF xxx	xxx = 576 , 536 , 326
	2.5 / 3.3	GCPQF xxx	xxx = 576 , 536 , 326
	2.5 / 3.3	GPJFN xxx	xxx = 578 , 538
Square Wave LVDS	2.5 / 3.3	GDQN xxx	xxx = 576 , 536 , 326
	2.5 / 3.3	GDQF xxx	xxx = 576 , 536 , 326
	2.5 / 3.3	GCDQF xxx	xxx = 576 , 536 , 326
	1.8 / 2.5 / 3.3	GDJFN xxx	xxx = 578 , 538
Square Wave HCSL	1.8 / 2.5 / 3.3	GCJFN xxx	xxx = 578 , 538
Square Wave CML	1.8 / 2.5 / 3.3	GQJFN xxx	xxx = 578 , 538

Output Wave Output Logic	Supply Voltage	Product Series	SMD types	Thru-Hole types
Square Wave CMOS	1.8 / 3.3	G x x	-----	xx = 8,14
	1.8 / 3.3	G x x x	xxx = 576 , 536 , 326 , 226	-----
	2.5 / 3.3	GTQN xxx	xxx = 576 , 536 , 326	
	2.5 / 3.3	GTQF xxx	xxx = 576 , 536 , 326	
	1.8 / 2.5 / 3.3	GTJFN xxx	xxx = 578 , 538	
	2.5 / 3.3	GCTQF xxx	xxx = 576 , 536 , 326	

"xxx" = package code

Part Number Format and Example

[1]	[2]	-	[3]	-	[4]	[5]	-	[6]
Supply Voltage	Holder Type		Frequency Stability		Pulling Range	Range Code		Center Frequency

Ex.	(1)	18	G14	-	B	-	80	N	-	35.328
	(2)	3	GTQF576	-	C20	-	150	M	-	200.000

Ex (1): 18G14 - B - 80N - 35.328 [1.8V , G14 type , ±50ppm from -20°C to 70°C , Pulling : ±80ppm (min.) , 35.328MHz]

Ex (2): 3GTQF576 - C20 - 150M - 200.000 [3.3V , GTQF576 type , ±20ppm from -20°C to 70°C , Pulling : ±150ppm (max.) , 200.000MHz]

[1]	Supply voltage , " 18 " for +1.8V ; " 25 " for +2.5V ; " 3 " for +3.3V
[2]	Holder Type
[3]	-20°C ~ 70°C " A " ± 25ppm ; " B " ± 50ppm ; " C " ± 100ppm ; If non-standard please enter the desired stability after " C " , for example " C15 " : represents ±15ppm over -20 to +70°C
	-40°C ~ 85°C " D " ± 25ppm ; " E " ± 50ppm ; " F " ± 100ppm ; If non-standard please enter the desired stability after " F " , for example " F20 " : represents ±20ppm over -40 to +85°C
[4]	Frequency Pulling Range
[5]	Pulling Range Code " M " stands for maximum ; " N " stands for minimum ; " T " stands for typical (tolerance is ± 20%)
[6]	Center Frequency in MHz

Production Marking Rules

G_8 , G_14	G536 , G576
G_226 , G_326	

Part Number Formats and Product Marking Rules

[VCXO] Voltage Controlled Crystal Oscillators

Production Marking Rules

<p style="text-align: center;">G_QF576 , G_QN576</p>	<p style="text-align: center;">G_QF536 , G_QN536</p>
<p style="text-align: center;">G_QF326 , G_QN326</p>	<p style="text-align: center;">G_JFN578</p>
<p style="text-align: center;">GC_QF576</p>	<p style="text-align: center;">G_JFN538</p>
<p style="text-align: center;">GC_QF536</p>	<p style="text-align: center;">GC_QF326</p>

Table 1	-20°C ~ 70°C	"A" ± 25ppm ; "B" ± 50ppm ; "C" ± 100ppm ; If non-standard please enter the desired stability after "C", Ex: "C15": represents ±15ppm over -20 to +70°C
	-40°C ~ 85°C	"D" ± 25ppm ; "E" ± 50ppm ; "F" ± 100ppm ; If non-standard please enter the desired stability after "F", Ex: "F20": represents ±20ppm over -40 to +85°C

Table 2	Month	Jan.	Feb.	Mar.	Apr.	May	Jun.	Jul.	Aug.	Sep.	Oct.	Nov.	Dec.
	Code	A	B	C	D	E	F	G	H	I	J	K	L

Table 3	Supply Voltage	5.0 V	3.3 V	3.0 V	2.8 V	2.5 V	1.8 V	1.5 V	1.2 V	1.0 V
		B	D	E	F	H	J	L	N	P

Part Number Formats and Product Marking Rules

[TCXO vs VCTCXO] Temperature Compensated Crystal Oscillators

Holder Type

Waveform	TCXO	VCTCXO	SMD types	Thru-Hole types
Clipped Sine Wave	M x x S	VM x x S	x x = 21 , 22 , 32 , 53 , 57 , 572	x x = 8 , 9 , 14 , 15 , 39
CMOS output	M x x T	VM x x T	x x = 32 , 53 , 572	
	M x x 1 T	-----	x x = 21 , 22 , 32	
	ME x x T	-----	x x = 21 , 32	
	MTF x x x T	VMTF x x x T	x x x = 326 , 538	
	MQN x x x T	VMQN x x x T	x x x = 326 , 574	
LVPECL output	MQF x x x T	VMQF x x x T	x x x = 326 , 574	-----
	MJF x x x P	VMJF x x x P	x x x = 326 , 538	
	MQN x x x P	VMQN x x x P	x x x = 326 , 576	
LVDS output	MQF x x x P	VMQF x x x P	x x x = 326 , 576	
	MJF x x x D	VMJF x x x D	x x x = 326 , 538	
	MQN x x x D	VMQN x x x D	x x x = 326 , 576	
HCSL output	MQF x x x D	VMQF x x x D	x x x = 326 , 576	
	MJF x x x C	VMJF x x x C	x x x = 326 , 538	
CML output	MJF x x x Q	VMJF x x x Q	x x x = 326 , 538	

" x x x " = package code

Part Number Format and Example

	[1]	[2]	[3]		[4]		[5]		[6]	
	Holder Type	Output Wave	Supply Voltage	-	Center Frequency	-	Frequency Stability	/	Operating Temp. Range	
Examples	(1)	VM32	T	33	-	10.000	-	1.5	/	-20+70
	(2)	M53	S	3	-	20.000	-	2.5	/	-30+75
	(3)	MQN576	P	33	-	155.520	-	1.0	/	0+50

Ex (1): VM32T33 - 10.000 - 1.5 / -20+70 [VCTCXO , VM32 type , CMOS output , 3.3V , 10.000MHz , ±1.5ppm from -20°C to 70°C]

Ex (2): M53S3 - 20.000 - 2.5 / -30+75 [TCXO , M53 type , Clipped Sine Wave , 3.0V , 20.000MHz , ±2.5ppm from -30°C to 75°C]

Ex (3): MQN576P33 - 155.520 - 1.0 / 0+50 [TCXO , MQN576 type , LVPECL differential , 3.3V , 155.520MHz , ±1.0ppm from 0°C to 50°C]

[1]	Holder Type " M " stands for TCXO , " VM " stands for VCTCXO
[2]	" S " stands for Clipped Sine Wave ; " T " stands for CMOS output ; " D " stands for LVDS differential ; " P " stands for LVPECL differential ; " C " stands for HCSL output ; " Q " stands for CML output ex 1 : VM32T --- TCXO , VM32 package , CMOS output
[3]	Supply Voltage , " 18 " stands for +1.8V ; " 25 " stands for +2.5V ; " 3 " stands for +3.0V ; " 33 " stands for +3.3V
[4]	Center Frequency in MHz
[5]	Frequency stability in ± _ ppm ; ex 1 : ± 1.5ppm --- 1.5 , ex 2 : ± 2.5ppm --- 2.5 , ex 3 : ± 1.0ppm --- 1.0
[6]	Operating temperature range in °C ex 1 : -20 °C to 70 °C ----- -20+70 ; ex 2 : -30 °C to 75 °C ----- -30+75 ; ex 3 : 0 °C to 50 °C ----- 0+50

Production Marking Rules

General (VC)TCXO package types marking rules	(V)M572_	(V)M32_ , (V)M22_ , (V)M21_
<p> M: TCXO VM: VCTCXO Output waveform : T : CMOS output S : Clipped sine wave P : LVPECL output D : LVDS output Supply Voltage 25 : for + 2.5 V 3 : for + 3.0 V 33 : for + 3.3 V Pin # 1 indicator lot code (Month) : Table 2 (Year) : ex : 2021 - 1 </p>	<p> Supply Voltage 25 : for + 2.5 V 3 : for + 3.0 V 33 : for + 3.3 V M : for TCXO VM : for VCTCXO Frequency 20.000MHz -- 20.000 lot code (Month) : Table 2 (Year) : ex : 2021 -- 1 Output waveform : T : CMOS output S : Clipped sine wave Pin # 1 indicator </p>	<p> M : for TCXO VM : for VCTCXO Freq. ex : 20.000 - 20 (month) : -- Table 2 (Year) ex : 2024 - 4 Mercury Logo and Pin#1 Supply Voltage : -- Table 3 </p>

Part Number Formats and Product Marking Rules

[TCXO vs VCTCXO] Temperature Compensated Crystal Oscillators

Production Marking Rules

ME32 , ME21	M321T , M211T , M221T	(V)M57_ , (V)M53_
 <p>32K : 32.768kHz Supply Voltage code: "D" +3.3V "H" +2.5V "J" +1.8V Pin #1 indicator Week code -- Table 4 (Year) ex : 2024 - 4</p>	 <p>M : for TCXO VM : for VCTCXO Freq. ex : 20.000 - 20 (month) : -- Table 2 (Year) ex : 2024 - 4 Supply Voltage : -- Table 3 Mercury Logo and Pin#1</p>	 <p>M : for TCXO VM : for VCTCXO Frequency ex : 20.000 - 20 lot code (Month) : Table 2 (Year) : ex : 2025 -- 5 Output waveform : T : CMOS output S : Clipped sine wave Pin #1 indicator</p>
(V)MQN574_ , (V)MQF574_		(V)MQN576_ , (V)MQF576_
 <p>M : for TCXO VM : for VCTCXO Product Series VMQ_XXXX Frequency ex : 1500.000 - 1500 (Month) : Table 2 (Year) : ex : 2024 - 4 Output waveform : T : CMOS output P : PECL output D : LVDS output Pin #1 indicator</p>		 <p>M : for TCXO VM : for VCTCXO Product Series VMQ_XXXX Frequency ex : 1500.000 - 1500 (Month) : Table 2 (Year) : ex : 2024 - 4 Output waveform : T : CMOS output P : PECL output D : LVDS output Pin #1 indicator</p>
(V)MQF326_ , (V)MQN326_ , (V)MTF326_	(V)MJF538_ , (V)MTF538_	(V)MJF326_
 <p>Frequency ex : 1500.000 - 1500 Pin #1 indicator M XX (Month) --- Table 2 (Year) ex : 2024 - 4 Mercury Logo</p>	 <p>Frequency ex : 2100.000 - 2100 Pin #1 indicator M XX (Month) -- Table 2 (Year) ex : 2024 - 4</p>	 <p>Frequency ex : 2100.000 - 2100 Pin #1 indicator M XX (Month) -- Table 2 (Year) ex : 2024 - 4</p>

Table 2	Month	Jan.	Feb.	Mar.	Apr.	May	Jun.	Jul.	Aug.	Sep.	Oct.	Nov.	Dec.
	Code	A	B	C	D	E	F	G	H	I	J	K	L

Table 3	Supply Voltage	5.0 V	3.3 V	3.0 V	2.8 V	2.5 V	1.8 V	1.5 V	1.2 V	1.0 V
			B	D	E	F	H	J	L	N

Table 4 Week Code	Week	1	2	3	4	5	6	7	8	9	10	11	12	13
	Code	A	B	C	D	E	F	G	H	I	J	K	L	M
	Week	14	15	16	17	18	19	20	21	22	23	24	25	26
	Code	N	O	P	Q	R	S	T	U	V	W	X	Y	Z
	Week	27	28	29	30	31	32	33	34	35	36	37	38	39
	Code	a	b	c	d	e	f	g	h	i	j	k	l	m
	Week	40	41	42	43	44	45	46	47	48	49	50	51	52
	Code	n	o	p	q	r	s	t	u	v	w	x	y	z

Part Number Formats and Product Marking Rules

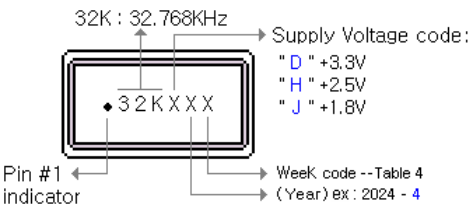
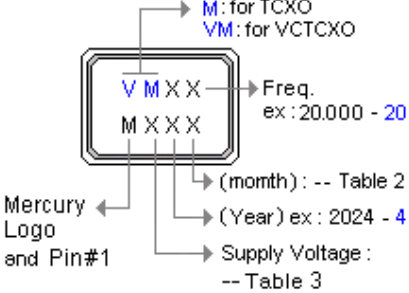
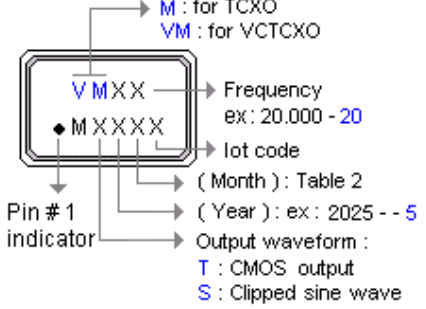
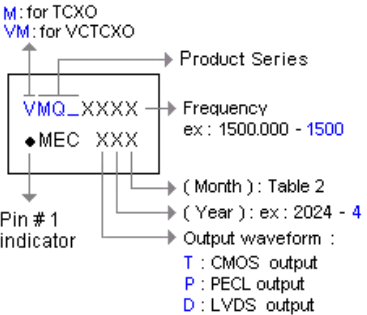
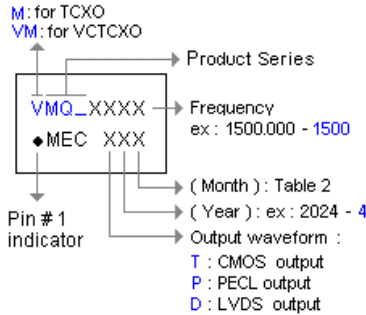
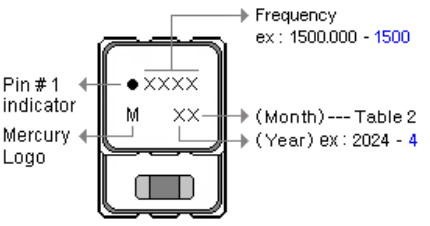
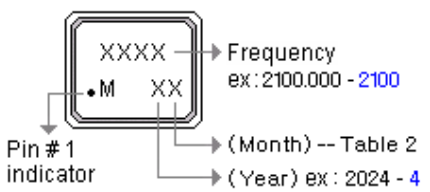
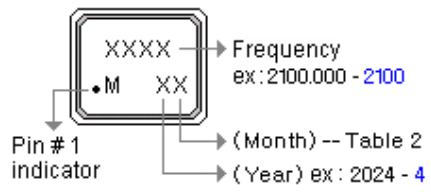
[OCXO] Oven Controlled Crystal Oscillators

Holder Type

Type	Thru-Hole types	SMD types	Waveform
OC x x	x x = 13 , 14 , 18 , 19 , 32	x x = 12 , 41 , 51	Square Wave ; True Sine Wave ; Clipped Sine Wave

Part Number Format and Example

[1]	[2]	[3]	-	[4]	-	[5]	/	[6]
Holder Type	Output Wave	Supply Voltage		Center Frequency		Frequency Stability		Operating Temp. Range
(1) OC14	T	5	-	5.000	-	10	/	-40+85
(2) OC18	E	5	-	100.000	-	100	/	-30+70
(3) OC51	S	3	-	10.000	-	30	/	-20+70
(4) OC12	E	3	-	10.000	-	200	/	0+70

- Ex (1): OC14T5 - 5.000 - 10 / -40+85 [OC14 type , Square Wave , 5.0V , 5.000MHz , ± 10ppb from -40°C to 85°C]
 Ex (2): OC18E5 - 100.000 - 100 / -30+70 [OC18 type , True Sine Wave , 5.0V , 100.000MHz , ± 100ppb from -30°C to 70°C]
 Ex (3): OC51S3 - 10.000 - 30 / -20+70 [OC51 type , Clipped Sine Wave , 3.3V , 10.000MHz , ± 30ppb from -20°C to 70°C]
 Ex (4): OC12E3 - 10.000 - 200 / 0+70 [OC12 type , True Sine Wave , 3.3V , 10.000MHz , ± 200ppb from 0°C to 70°C]

[1]	Holder Type " OC_ _ " stands for OCXO ,
[2]	" T " stands for Square Wave , " E " stands for True Sine Wave , " S " stands for Clipped Sine Wave ex 1 : OC14T , OC14 package , Square Wave ; ex 2 : OC18E , OC18 package , True Sine Wave ; ex 3 : OC51S , OC51 package , Clipped Sine Wave ; ex 4 : OC12E , OC12 package , True Sine Wave
[3]	Supply voltage , " 5 " for 5.0V D.C , " 3 " for 3.3V D.C
[4]	Center Frequency in MHz
[5]	Frequency stability in ±_ ppb ; ex 1 : ±10ppb --- 10 , ex 2 : ± 100ppb --- 100 , ex 3 : ± 30ppb --- 30 , ex 4 : ± 200ppb --- 200
[6]	Operating temperature range in °C ex 1 : -40 °C to 85°C ----- -40+85 ; ex 2 : -30 °C to 70°C ----- -30+70 ; ex 3 : -20 °C to 70°C ----- -20+70 ; ex 4 : 0 °C to 70°C ----- 0+70

Production Marking Rules

General OCXO package types marking rules

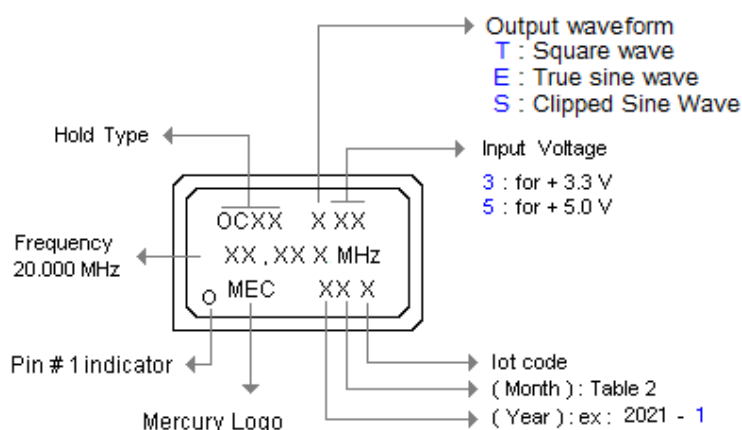

Table 2	Month	Jan.	Feb.	Mar.	Apr.	May	Jun.	Jul.	Aug.	Sep.	Oct.	Nov.	Dec.
	Code	A	B	C	D	E	F	G	H	I	J	K	L

Part Number Formats and Product Marking Rules

[M. C. F.] Monolithic Crystal Filters

Holder Type

SMD Types :

MQ

Dip Types :

49T

U1

U5

S1

S2

L1

L2

SMD Type (7.0 * 5.0 * 1.3 mm) Part Number Format and Example

[1]	[2]	[3]	[4]
Frequency Code	MQ	Width Code	Poles Code

Examples	45	MQ	15	B
----------	----	----	----	---

Ex : 45MQ15B [45.000MHz , SMD type MQ , Passband : ±7.5KHz , 4poles]

Dip Type Part Number Format and Example

[1]	[2]	[3]	[4]	[5]	[6]
Frequency Code	M	Width Code	Poles Code	Holder Type	Temperature range

Examples	21	M	15	B	U5
----------	----	---	----	---	----

Ex : 21M15BU5 [21.400MHz , Dip Type , Passband : ±7.5KHz , 4poles , RoHS compliant , U5 Dip type]

[1]	Freq. code : " 10 " for 10.700MHz , " 21 " for 21.400MHz , " 21.7 " for 21.700MHz , " 45 " for 45.000MHz , " 50.85 " for 50.850MHz Freq. code : If none standard freq. please show frequency with one decimal point .
[2]	" M " Dip Type , " MQ " SMD Type
[3]	Pass band width (3dB) (min.) " 7.5 " for ± 3.75KHz , " 15 " for ± 7.5KHz , " 20 " for ± 10KHz , " 30 " for ± 15KHz ,
[4]	No. of poles " A " for 2 poles , " B " for 4 poles , " C " for 6 poles , " D " for 8 poles
[5]	Dip type holder type
[6]	Standard operating temperature range is -20°C to 70°C , If non-standard please enter the desired temp. range after " / " , for example " / -30+70 " : -30°C to 70°C

Production Marking Rules

General MCF package types marking rules

U5 series	U1 , 49T series	MQ series
 <p>Freq. code → Pass Bandwidth code No. of poles A : for 2 poles , B : for 4 poles , C : for 6 poles , D : for 8 poles</p> <p>XX M XXX MEC XXX</p> <p>lot code (Month) : Table 2 (Year) : ex : 2020 --- 0 2021 --- 1</p>	 <p>Freq. code → Pass Bandwidth code No. of poles A : for 2 poles , B : for 4 poles , C : for 6 poles , D : for 8 poles</p> <p>XX M XXX MEC XXX</p> <p>lot code (Month) : Table 2 (Year) : ex : 2020 --- 0 2021 --- 1</p>	 <p>Frequency code → Pass Bandwidth code No. of poles A : for 2 poles , B : for 4 poles (1 pc) , B2 : for 4 poles (1 pair) ,</p> <p>XX M XX X MEC XXX</p> <p>lot code (Month) : Table 2 (Year) : ex : 2020 --- 0 2021 --- 1</p>

Table 2	Month	Jan.	Feb.	Mar.	Apr.	May	Jun.	Jul.	Aug.	Sep.	Oct.	Nov.	Dec.
	Code	A	B	C	D	E	F	G	H	I	J	K	L

Emboss Taping and Reel Specifications

[Crystal Units]

[M . C . F . Units]

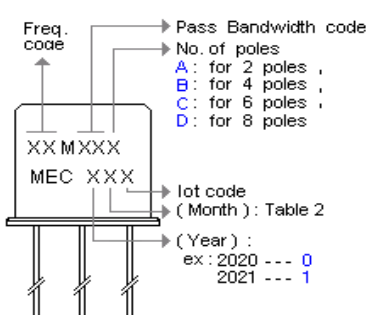
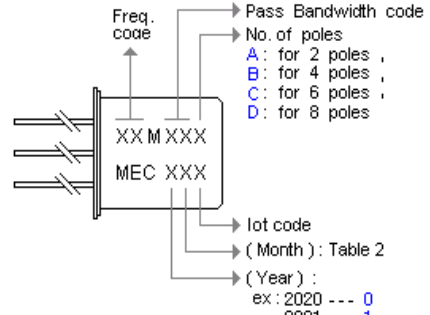
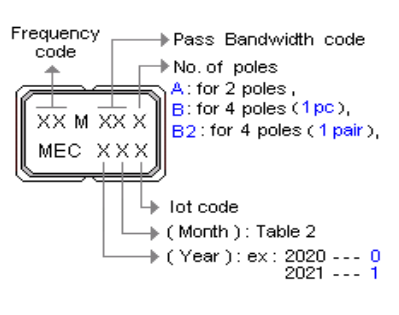
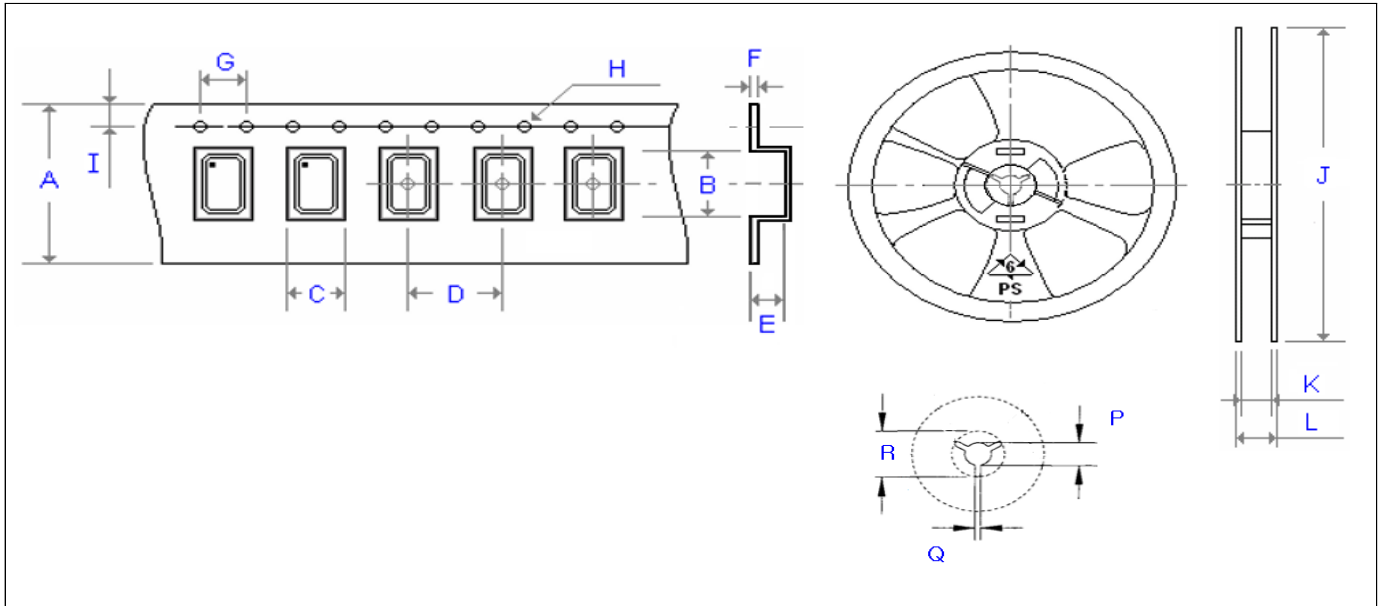

Carrier Type Dimensions (unit : mm) ±0.3mm

	A	B	C	D	E	F	G	H	I	pcs / reel
X11	8.00	1.79	1.39	4.00	0.45	0.25	4.00	∅ 1.50	1.75	3000
X21	8.00	2.30	1.90	4.00	0.60	0.20	4.00	∅ 1.50	1.75	3000
X22	8.00	2.80	2.25	4.00	1.10	0.30	4.00	∅ 1.50	1.75	3000
X32	8.00	3.40	2.70	4.00	1.40	0.25	4.00	∅ 1.50	1.75	3000
X2012	8.00	2.25	1.45	4.00	0.75	0.25	4.00	∅ 1.50	1.75	3000
X3215	12.00	3.40	1.70	4.00	1.00	0.30	4.00	∅ 1.50	1.75	3000
MJ	12.00	5.30	3.60	8.00	1.40	0.30	4.00	∅ 1.50	1.75	1000
MQ	16.00	7.20	5.40	8.00	1.80	0.30	4.00	∅ 1.50	1.75	1000
M49	24.00	15.00	5.00	12.00	4.25	0.40	4.00	∅ 1.50	1.75	1000
ML49	24.00	14.80	5.00	12.00	3.50	0.40	4.00	∅ 1.50	1.75	1000
MP4 (24)	24.00	13.30	5.10	12.00	4.20	0.40	4.00	∅ 1.50	1.75	1000
MP5 (25)	24.00	13.40	5.10	12.00	5.20	0.40	4.00	∅ 1.50	1.75	1000

Reel Dimensions (unit : mm) +2.0 / -0.0mm

	J	K	L	P	Q	R	pcs / reel
X11	180.00	9.00	12.00	13.20	2.10	-	3000
X21	180.00	9.00	12.00	13.20	2.10	-	3000
X22	180.00	9.00	12.00	13.20	2.10	-	3000
X32	180.00	9.00	12.00	13.20	2.10	-	3000
X2012	180.00	9.00	12.00	13.20	2.10	-	3000
X3215	180.00	13.00	16.00	13.20	2.50	-	3000
MJ	180.00	13.00	16.00	13.20	2.50	-	1000
MQ	180.00	17.20	19.30	13.30	2.20	22.00	1000
M49	330.00	24.50	29.10	13.00	2.20	17.30	1000
ML49	330.00	24.50	29.10	13.00	2.20	17.30	1000
MP4 (24)	330.00	24.50	29.10	13.00	2.20	17.30	1000
MP5 (25)	330.00	24.50	29.10	13.00	2.20	17.30	1000

Emboss Taping and Reel Specifications

[Crystal Oscillator Units]

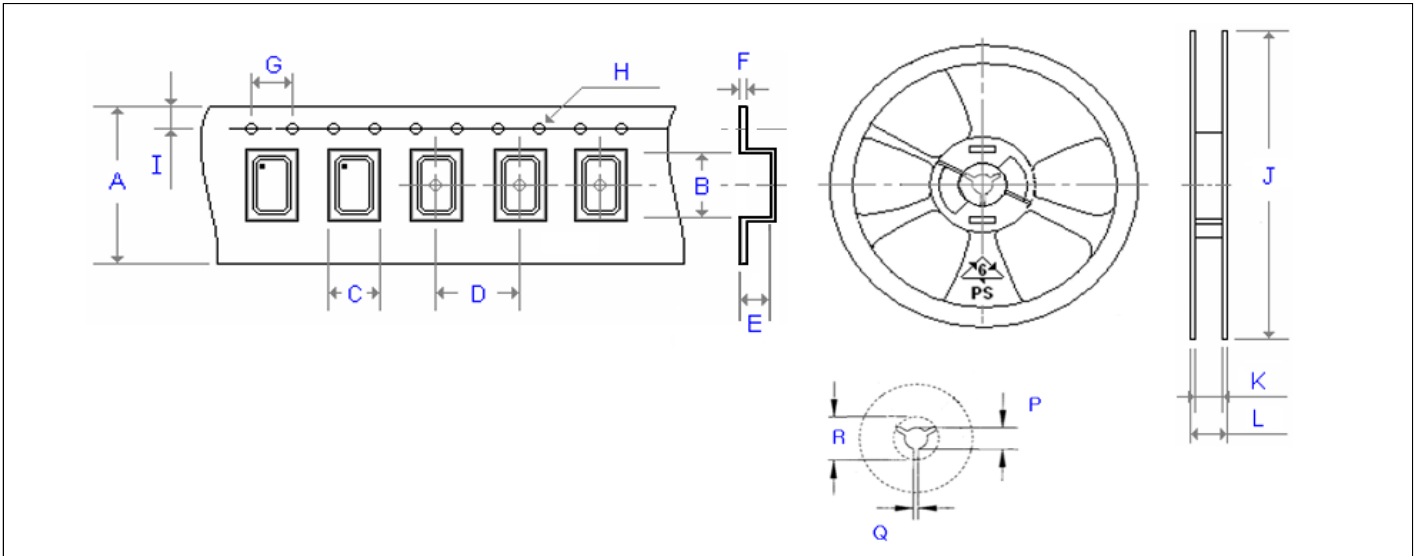

Carrier Type Dimensions (unit : mm) ±0.3mm

	A	B	C	D	E	F	G	H	I	pcs / reel
H21	8.00	2.30	1.90	4.00	0.90	0.25	4.00	Ø 1.50	1.75	3000
H_22	8.00	2.80	2.25	4.00	1.10	0.30	4.00	Ø 1.50	1.75	3000
H_32	8.00	3.40	2.70	4.00	1.40	0.25	4.00	Ø 1.50	1.75	3000
H_53	12.00	5.30	3.60	8.00	1.40	0.30	4.00	Ø 1.50	1.75	1000
H_57	16.00	7.30	5.30	8.00	1.90	0.30	4.00	Ø 1.50	1.75	1000
SWO	16.00	7.20	5.40	8.00	1.80	0.30	4.00	Ø 1.50	1.75	1000
H_216	8.00	2.30	1.90	4.00	0.90	0.25	4.00	Ø 1.50	1.75	3000
H_226	8.00	2.80	2.25	4.00	1.10	0.30	4.00	Ø 1.50	1.75	3000
H_326	8.00	3.40	2.70	4.00	1.40	0.25	4.00	Ø 1.50	1.75	3000
H_536	12.00	5.30	3.60	8.00	1.40	0.30	4.00	Ø 1.50	1.75	1000
H_576	16.00	7.30	5.30	8.00	1.90	0.30	4.00	Ø 1.50	1.75	1000
H_328	8.00	3.40	2.70	4.00	1.40	0.25	4.00	Ø 1.50	1.75	3000
H_538	12.00	5.40	3.60	8.00	1.70	0.30	4.00	Ø 1.50	1.75	1000
H_578	16.00	7.30	5.30	8.00	1.90	0.30	4.00	Ø 1.50	1.75	1000
H_43	24.00	11.80	10.00	16.00	5.00	0.30	4.00	Ø 1.50	1.75	500

Reel Dimensions (unit : mm) +2.0 / -0.0mm

	J	K	L	P	Q	R	pcs / reel
H21	180.00	9.00	12.00	13.20	2.10	-	3000
H_22	180.00	9.00	12.00	13.20	2.10	-	3000
H_32	180.00	9.00	12.00	13.20	2.10	-	3000
H_53	180.00	13.00	16.00	13.20	2.50	-	1000
H_57	180.00	17.20	19.30	13.30	2.20	22.00	1000
SWO	180.00	17.20	19.30	13.30	2.20	22.00	1000
H_216	178.00	8.40	11.40	13.30	2.50	20.50	3000
H_226	180.00	8.40	11.40	13.20	2.10	-	3000
H_326	180.00	9.00	12.00	13.20	2.10	-	3000
H_536	180.00	13.00	16.00	13.20	2.50	-	1000
H_576	180.00	17.20	19.30	13.30	2.20	22.00	1000
H_328	180.00	8.00	12.00	13.20	2.10	-	3000
H_538	180.00	13.00	16.00	13.20	2.50	-	1000
H_578	180.00	17.20	19.30	13.30	2.20	22.00	1000
H_43	330.00	24.50	29.10	13.00	2.20	17.30	500

Emboss Taping and Reel Specifications

[VCXO]

[(VC)TCXO]

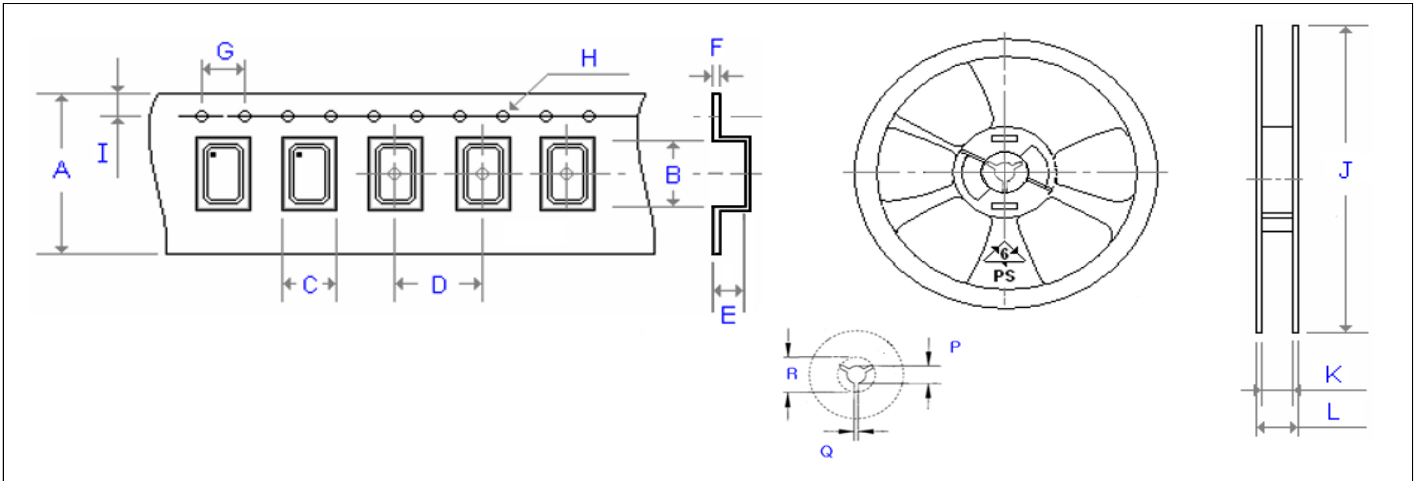

Carrier Type Dimensions (unit : mm) ±0.3mm

	A	B	C	D	E	F	G	H	I	pcs / reel
G_226	8.00	2.80	2.25	4.00	1.10	0.30	4.00	Ø 1.50	1.75	3000
G_326	8.00	3.40	2.70	4.00	1.40	0.25	4.00	Ø 1.50	1.75	3000
G_536	12.00	5.30	3.60	8.00	1.40	0.30	4.00	Ø 1.50	1.75	1000
G_576	16.00	7.30	5.30	8.00	1.90	0.30	4.00	Ø 1.50	1.75	1000
G_538	12.00	5.40	3.60	8.00	1.70	0.30	4.00	Ø 1.50	1.75	1000
G_578	16.00	7.30	5.30	8.00	1.90	0.30	4.00	Ø 1.50	1.75	1000
(V)M21	8.00	2.30	1.90	4.00	0.90	0.25	4.00	Ø 1.50	1.75	3000
ME21	8.00	2.30	1.50	4.00	1.35	0.25	4.00	Ø 1.50	1.75	3000
(V)M22	8.00	2.80	2.25	4.00	1.10	0.30	4.00	Ø 1.50	1.75	3000
(V)M_32	8.00	3.71	2.80	4.00	1.75	0.25	4.00	Ø 1.50	1.75	3000
(V)M_326	12.00	3.60	2.90	4.00	1.70	0.30	4.00	Ø 1.50	1.75	1000
(V)M_53	12.00	5.30	3.60	8.00	1.40	0.30	4.00	Ø 1.50	1.75	1000
(V)M_538	12.00	5.40	3.60	8.00	1.70	0.30	4.00	Ø 1.50	1.75	1000
(V)M_57(2)	16.00	7.40	5.50	8.00	2.80	0.35	4.00	Ø 1.50	1.75	500
(V)M_43 (63)	24.00	11.80	10.00	16.00	5.00	0.30	4.00	Ø 1.50	1.75	500

Reel Dimensions (unit : mm) +2.0 / -0.0mm

	J	K	L	P	Q	R	pcs / reel
G_226	180.00	9.00	12.00	13.20	2.10	-	3000
G_326	180.00	9.00	12.00	13.20	2.10	-	3000
G_536	180.00	13.00	16.00	13.20	2.50	-	1000
G_576	180.00	17.20	19.30	13.30	2.20	22.00	1000
G_538	180.00	13.00	16.00	13.20	2.50	-	1000
G_578	180.00	17.20	19.30	13.30	2.20	22.00	1000
(V)M21	180.00	9.00	12.00	13.20	2.10	-	3000
ME21	180.00	9.00	12.00	13.20	2.10	-	3000
(V)M22	180.00	9.00	12.00	13.20	2.10	-	3000
(V)M_32	180.00	9.00	12.00	13.20	2.10	-	3000
(V)M_326	180.00	13.00	16.00	13.20	2.50	-	1000
(V)M_53	180.00	13.00	16.00	13.20	2.50	-	1000
(V)M_538	180.00	13.00	16.00	13.20	2.50	-	1000
(V)M_57(2)	180.00	17.20	19.30	13.30	2.20	22.00	500
(V)M_43 (63)	330.00	24.50	29.10	13.00	2.20	17.30	500

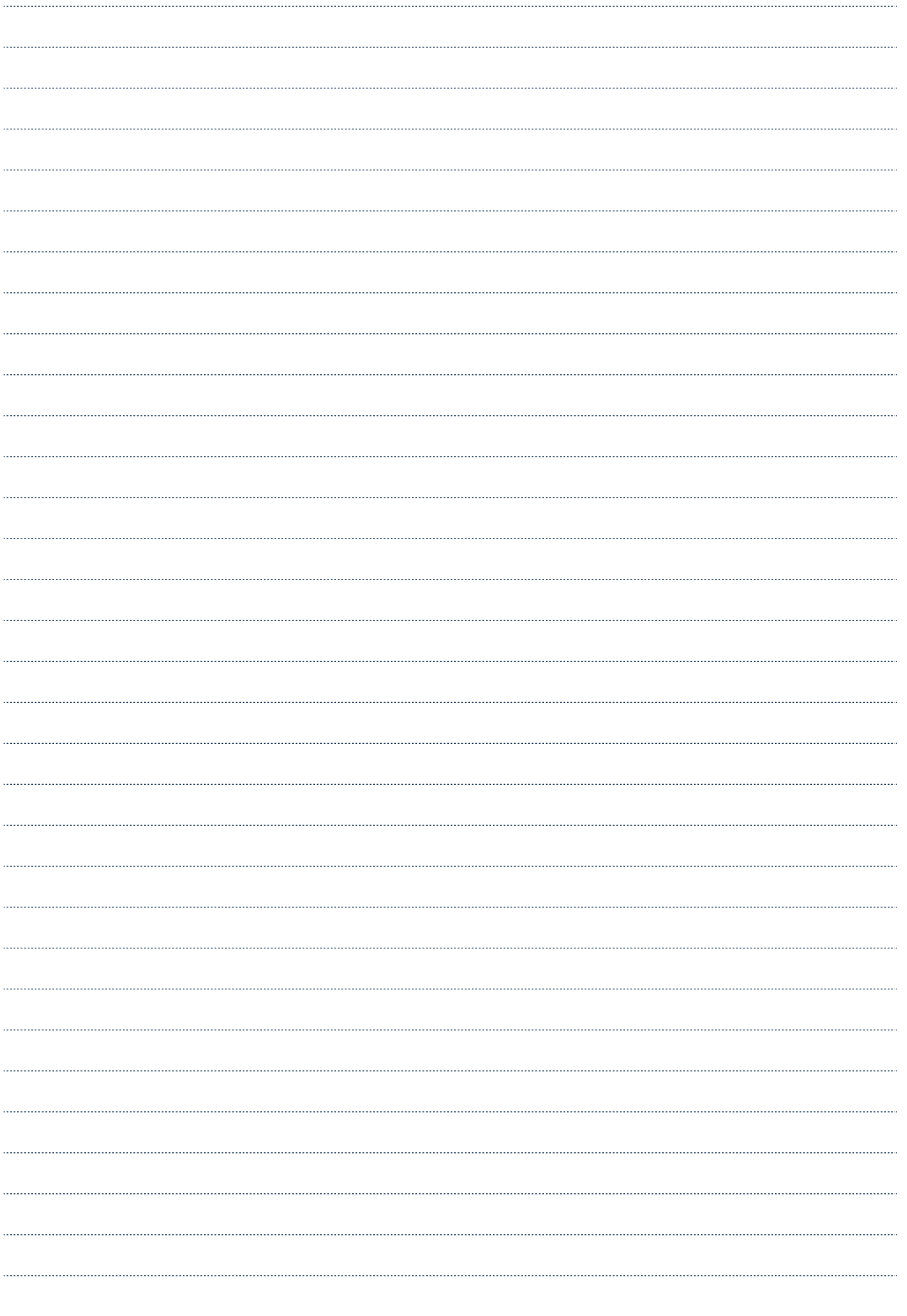

Mercury Electronic Ind. Co., Ltd.

CONTACT

TEL +886-2-2406-2779
FAX +886-2-2496-0769
EMAIL sales-tw@mercury-crystal.com

244012新北市瑞芳區頂坪路31號 (瑞芳工業區)
31, TING PING RD., SHUI-FONG IND. PARK, SHUI-FONG DIST., NEW TAIPEI CITY 224012, TAIWAN



www.mercury-crystal.com