



Product Summary:

PRODUCT SELECTION GUIDE

Output Wave Form: Square Wave					
TCXO	VCTCXO	Available Frequency Range	RoHS Compliant Equivalent Model		Package Description
Thru-Hole Types					
M38K	VM38K	32.768 KHz	M38GK	VM38GK	4 pin DIP
M39K	VM39K		M39GK	VM39GK	4 pin DIP
M14K	VM14K		M14GK	VM14GK	4 pin DIP. Hermetically sealed.
M15K	VM15K		M15GK	VM15GK	4 pin DIP. With trimmer
M8K	VM8K		M8GK	VM8GK	4 pin DIP. Half size. Hermetically sealed.
M9K	VM9K		M9GK	VM9GK	4 pin DIP. Half size. With trimmer
Gull Wing Surface Mount Types					
M55K	VM55K	32.768 KHz	N / A	N / A	4 pin gull wing
M47K	VM47K		M47GK	VM47GK	4 pin gull wing
M24K	VM24K		M24GK	VM24GK	4 pin gull wing. Hermetically sealed.
M25K	VM25K		M25GK	VM25GK	4 pin gull wing. With trimmer
M28K	VM28K		M28GK	VM28GK	4 pin gull wing. Half size. Hermetically sealed.
M29K	VM29K		M29GK	VM29GK	4 pin Gull wing. Half size. With trimmer
Leadless Surface Mount Types					
M62K	VM62K	32.768 KHz	M62GK	VM62GK	6 pad FR4 substrate. 2.5 mm H
M42K	VM42K		M42GK	VM42GK	4 pad FR4 substrate. 2.5mm H
M64K	VM64K		M64GK	VM64GK	6 pad FR4 substrate. 4.7 mm H
M44K	VM44K		M44GK	VM44GK	4 pad FR4 substrate. 4.7 mm H
M57K	VM57K		Same ⁽¹⁾	Same ⁽¹⁾	4 pad ceramic substrate. 5x7 mm
M53K	VM53K	Under development	Same ⁽¹⁾	Same ⁽¹⁾	4 pad ceramic substrate. 5x3.2 mm

For RoHS equivalent model please add “G” after the package code. For example: M14GK.

⁽¹⁾ M57T, VM57T, M53T and VM53T are RoHS compliant and lead free products. .

Note: Frequency tuning by the built-in mechanical trimmer is standard for all models except for M57K and VM57K.

Product Options

- No mechanical Trimmer models are available to allow for aqueous washing cycles

MERCURY www.mercury-crystal.com

Taiwan: TEL (886)-2-2406-2779, FAX (886)-2-0769, e-mail: sales-tw@mercury-crystal.com

U.S.A.: TEL (1)-909-466-0427, FAX (1)-909-466-0762, e-mail: sales-us@mercury-crystal.com

“TCXO” and “VCTCXO” “K” Series
Ultra Low Current, CMOS square wave



MERCURY
 Since 1973

General Specifications (at +25°C and specified input voltage)

Frequency Range		10 MHz ~ 32.0 MHz				
Output Wave Form		Square wave. Wave form code is “K”				
Initial Calibration Tolerance		Models with mechanical trimmer: < ±1 ppm. +25°C ±2°C. Models without mechanical trimmer: ±2 ppm at +25°C ±2°C.				
Standard Frequencies (partial list)		10.0, 12.8, 13.0, 14.4, 15.36, 16.384, 19.2, 19.440, 19.68, 20.0 MHz,				
Frequency Stability vs Temperature vs Aging vs Voltage Change vs Load Change vs reflow (SMD models only)		±1 ppm, ±1.5 ppm, ±2.0 ppm, ±2.5 ppm, ±3 ppm, or ±5 ppm, over operating temperature range. Referenced to frequency reading at +25°C. ±1.0 ppm max. first year at +25°C ±0.3 ppm max. for a ±5% input voltage change ±0.3 ppm max. for a ±10% loading condition change ±1 ppm max. 1 reflow and measured 24 hours afterwards				
Typical Operating Temperature Range (examples)		0°C to +60°C 0°C to +70°C -10°C to +60°C -20°C to +70°C -30°C to +60°C -30°C to +75°C -30°C to +85°C -40°C to +85°C. or custom.				
Output Voltage Level (peak to peak)		CMOS				
Mechanical Frequency Tuning		Standard ±3 ppm min. tuning Note: VM57 and VM53 have no mechanical trimmer built-in.				
		Option No mechanical trimmer built-in (for aqueous washing cycles). Part number: Please add “1” after the regular model prefix. For example: M381K3.				
Input Voltage Range		+2.8 V (voltage code is “28”)	+3.0 V (voltage code is “3”)	+3.3 V voltage code is “33”)		
Output Voltage Level	Logic High “1”	1.9V min.; 2.3V typ..	2.1V min.; 2.6V typ..	2.4V min.; 2.9V typ..		
	Logic Low “0”	0.27V typ.; 0.34V max.	0.29V typ.; 0.36V max.	0.32V typ.; 0.40V max.		
Current Consumption. V _{DD} =3.3V; 15 pF load (Over operating temperature range.)	12.8 MHz	2.3 mA typical	2.4 mA typical	2.6 mA typical		
	13.0 MHz	2.5 mA typical	2.6 mA typical	2.8 mA typical		
	14.4 MHz	2.6 mA typical	2.8 mA typical	3.1 mA typical		
	16.384 MHz	2.8 mA typical	3.0 mA typical	3.2 mA typical		
	19.2 MHz	3.2 mA typical	3.3 mA typical	3.6 mA typical		
	19.440 MHz	3.2 mA typical	3.4 mA typical	3.7 mA typical		
	20.0 MHz	3.2 mA typical	3.4 mA typical	3.7 mA typical		
26.0 MHz	3.6 mA typical	3.8 mA typical	4.1 mA typical			
Duty Cycle		45% ~55%. Measured at 1.4 V.				
Rise Time and Fall Time		4.0 n sec. typ; 0.3 V ↔ 3.0V with 15 pF load				
Pin 1 Options VCTCXO only	Control voltage	+1.5 V±1.0 V	+2.5 V±2.0 V. +1.5 V±1.0 V for VM57T5			
	Frequency Deviation Range	±5 ppm ~±12 ppm for +1.5 V±1.0 V				
	Slope Polarity	Positive slope. Positive voltage for positive frequency shift.				
	Linearity	10 % max.				
Start-Up Time.		10 m. sec. max. (reach 90% amplitude and at +25°C±2°C)				
Output Load		15 pF				
Fanout (Drive Capability)		12 mA typical; 17 mA max. (at TTL level).				
SSB Phase Noise at +25°C	Offset	100 Hz	1 KHz	10 KHz	100 KHz	1 MHz
	M14K3-27.000	-80 dBc/Hz	-110 dBc/Hz	-130 dBc/Hz	-135 dBc/Hz	-142 dBc/Hz

“TCXO” and “VCTCXO” “K” Series
Ultra Low Current, CMOS square wave



MERCURY
 Since 1973

RMS Period Jitter	3 ps max. (1 sigma, 1000 samples, with capacitive coupling between V _{DD} and ground)
Output Format	AC block, DC coupled

Note 1: Some specifications are package dependent. Please refer to the spec. sheet of individual packages once a package is selected.

Note 2: TCXO products ordered without mechanical and electrical frequency tuning should have a frequency tolerance of ± 2 ppm (at +25°C) and the frequency stability over temperature will be from that measured value.

Part Number Format and Examples:

Example of TCXO: M38K33-12.8-2.5/-30+75;										
Example of VCTCXO: VM38K33-12.800-2.5/-30+75										
V	M38	K	33	—	12.800	—	2.5	/	-30+75	: customer to specify
❶	❷	❸	❹		❺		❻		❼	
❶: “V” for VCTCXO; “blank” for TCXO ❷: Package code ❸: Wave form code “T” for Square wave ❹: Supply voltage code: “3” for +3.0V, “33” for “+3.3V, ❺: Frequency in MHz ❻: Frequency stability in \pm ppm ❼: Operating temperature range in °C										

Square Wave TCXO (VCTCXO) Test Circuit (example of VM14) and Output Wave Form:

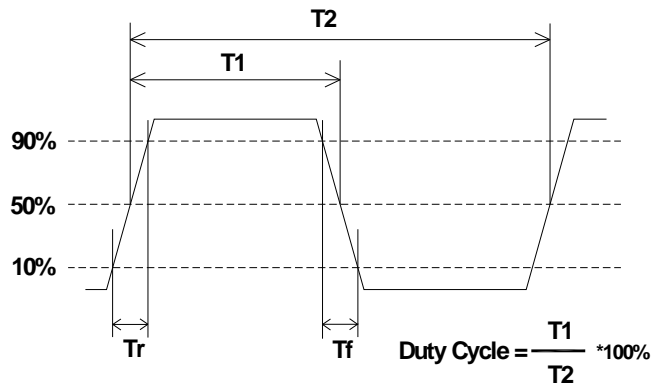
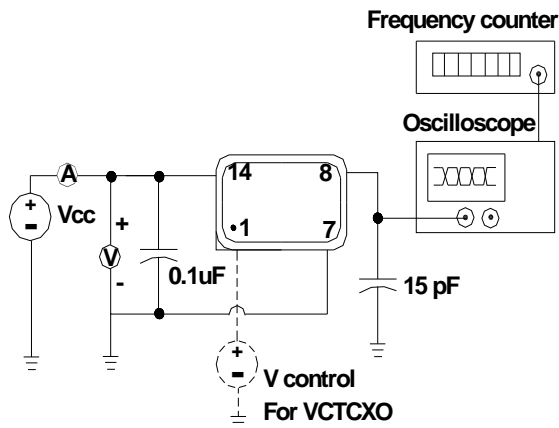

Package: M38K,VM38K

Open bottom

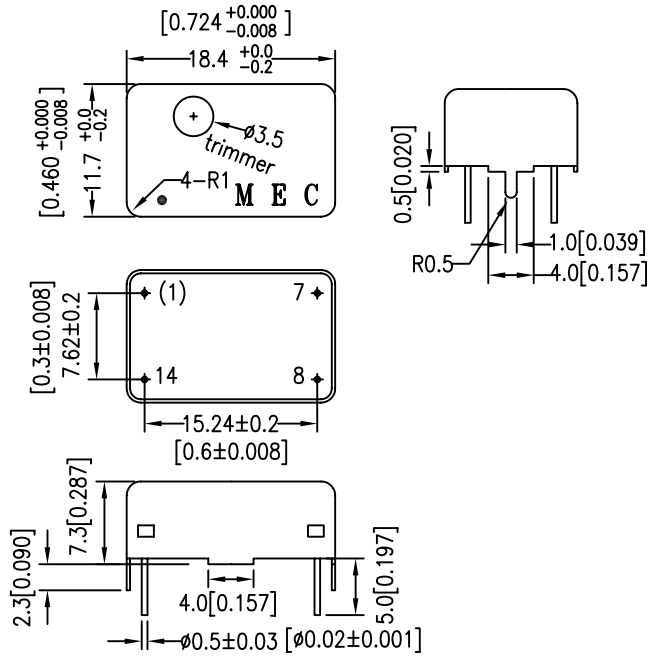

Pin Connections

- Pin 1: Voltage Control for VCTCXO; No physical pin 1 for TCXO
- Pin 7: Ground and case
- Pin 8: Output
- Pin 14: Supply Voltage

Package: M39K,VM39K

Unit: mm [inches]

Open bottom

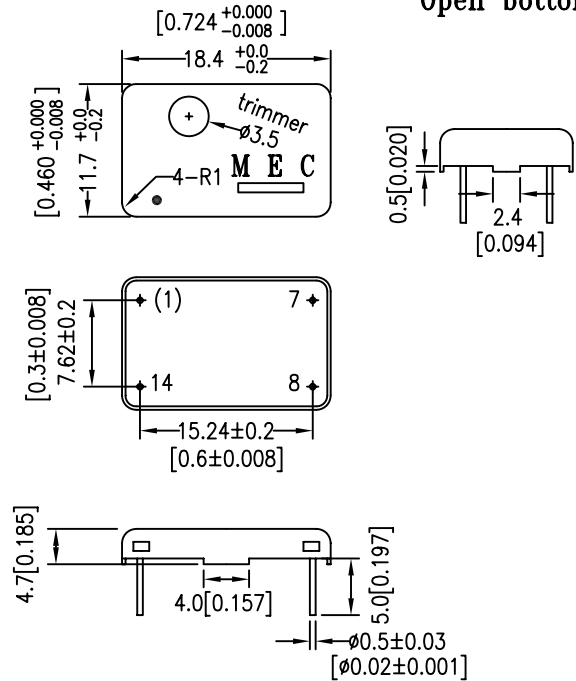

Pin Connections

- Pin 1: Voltage Control for VCTCXO; No physical pin 1 for TCXO
- Pin 7: Ground and case
- Pin 8: Output
- Pin 14: Supply Voltage

TCXO;VCTCXO

Package: M47K,VM47K

**Open bottom
Gull wing SMD**

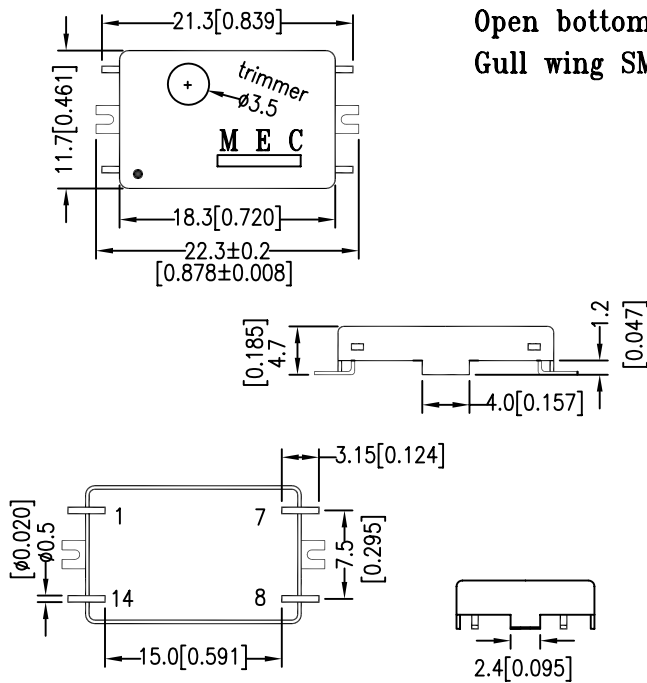

Pin Connections

- Pin 1: Voltage Control for VCTCXO. No Connection for TCXO.
- Pin 7: Ground and case
- Pin 8: Output
- Pin 14: Supply Voltage

Package: M55K,VM55K

**Open bottom
Gull wing SMD**

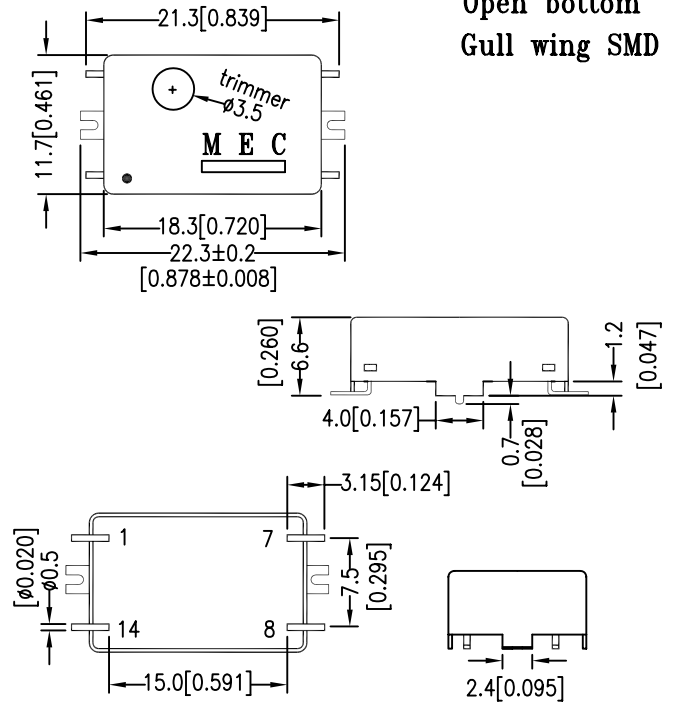

Pin Connections

- Pin 1: Voltage Control for VCTCXO. No Connection for TCXO.
- Pin 7: Ground and case
- Pin 8: Output
- Pin 14: Supply Voltage

Package: M14K,VM14K Hermetically Sealed DIP No Trimmer Access

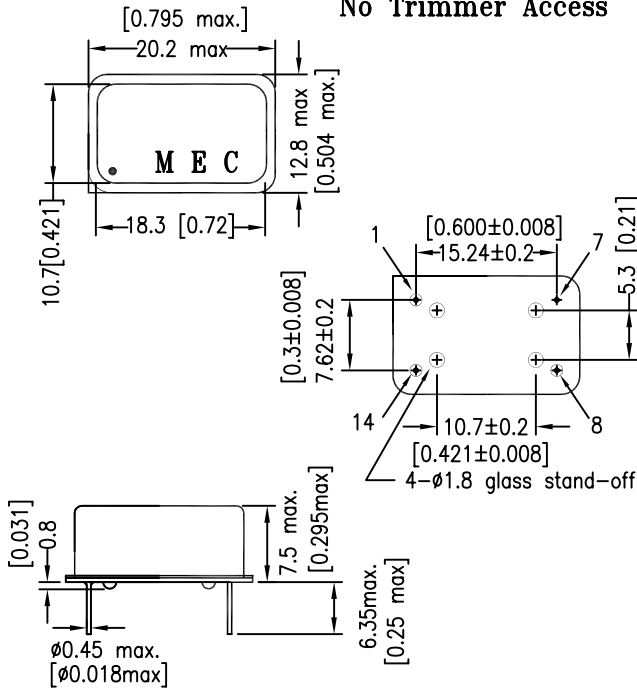

Pin Connections Square corner denotes pin 1
 Pin 1: Voltage Control for VCTCXO; No Connection for TCXO
 Pin 7: Ground and case
 Pin 8: Output
 Pin 14: Supply Voltage

Package: M15K,VM15K Unit: mm [inches] Sealed bottom

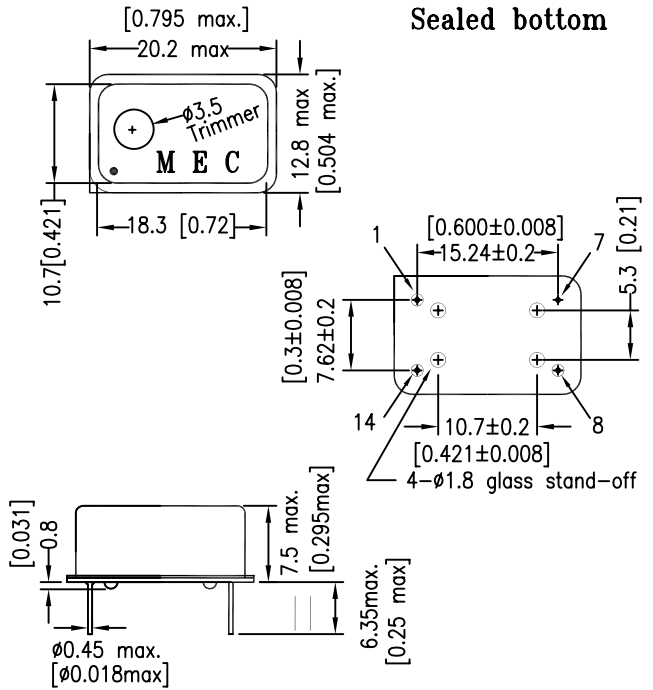

Pin Connections Square corner denotes pin 1
 Pin 1: Voltage Control for VCTCXO; No Connection for TCXO
 Pin 7: Ground and case
 Pin 8: Output
 Pin 14: Supply Voltage

TCXO;VCTCXO

Package: M24K,VM24K Hermetically sealed No trimmer access

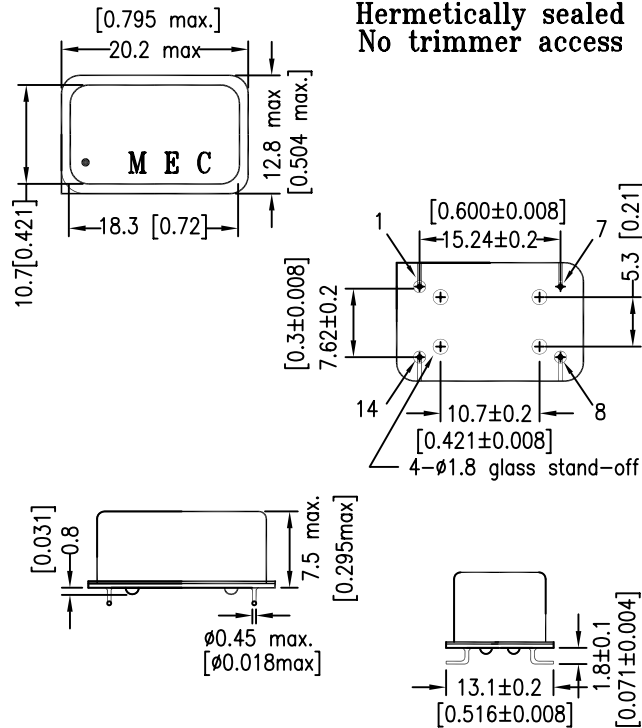

Pin Connections Square corner denotes pin 1
 Pin 1: Voltage Control for VCTCXO; No Connection for TCXO
 Pin 7: Ground and case
 Pin 8: Output
 Pin 14: Supply Voltage

Package: M25K,VM25K Sealed bottom

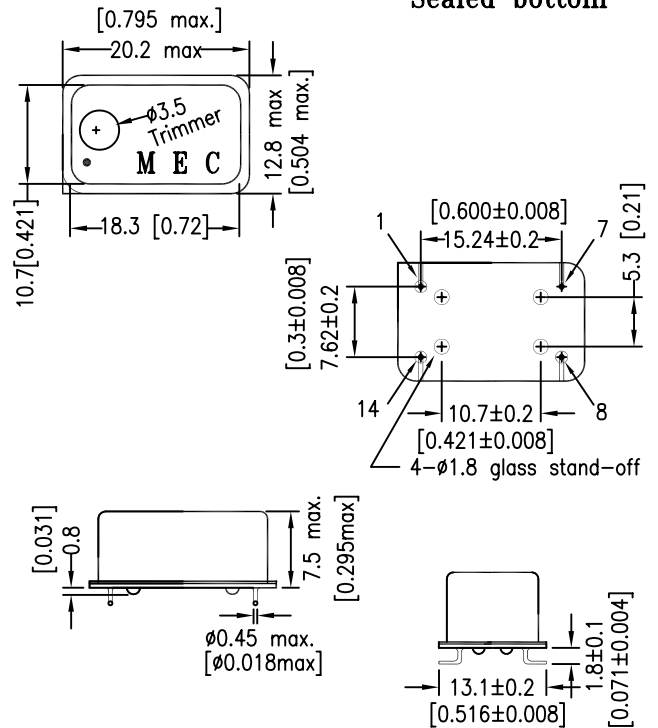

Pin Connections Square corner denotes pin 1
 Pin 1: Voltage Control for VCTCXO; No Connection for TCXO
 Pin 7: Ground and case
 Pin 8: Output
 Pin 14: Supply Voltage

Package: M8K,VM8K

Hermetically Sealed DIP
No trimmer Access

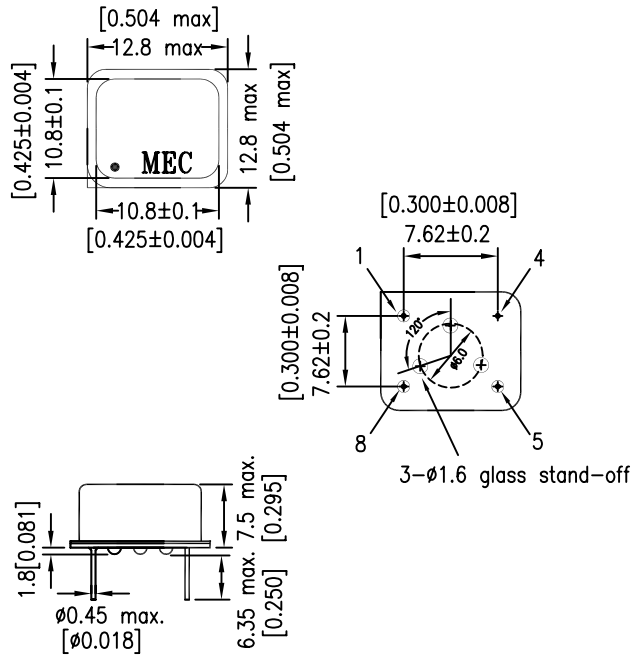

Pin Connections

Square corner denotes pin 1

- Pin 1: Voltage Control for VCTCXO or No Connection for TCXO
- Pin 4: Ground and case
- Pin 5: Output
- Pin 8: Supply Voltage

Package: M9K,VM9K

Unit: mm [inches]
Sealed bottom

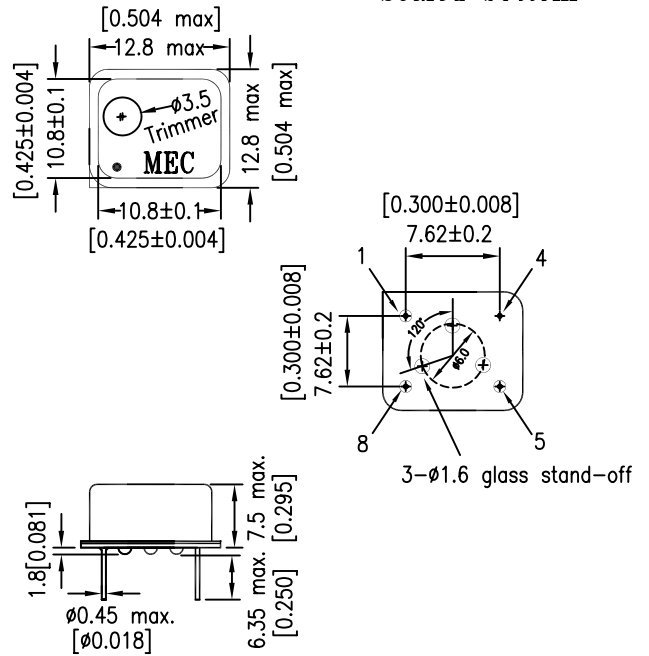

Pin Connections

Square corner denotes pin 1

- Pin 1: Voltage Control for VCTCXO or No Connection for TCXO
- Pin 4: Ground and case
- Pin 5: Output
- Pin 8: Supply Voltage

TCXO;VCTCXO

Package: M28K,VM28K

Hermetically Sealed
Gull Wing SMD
No trimmer Access

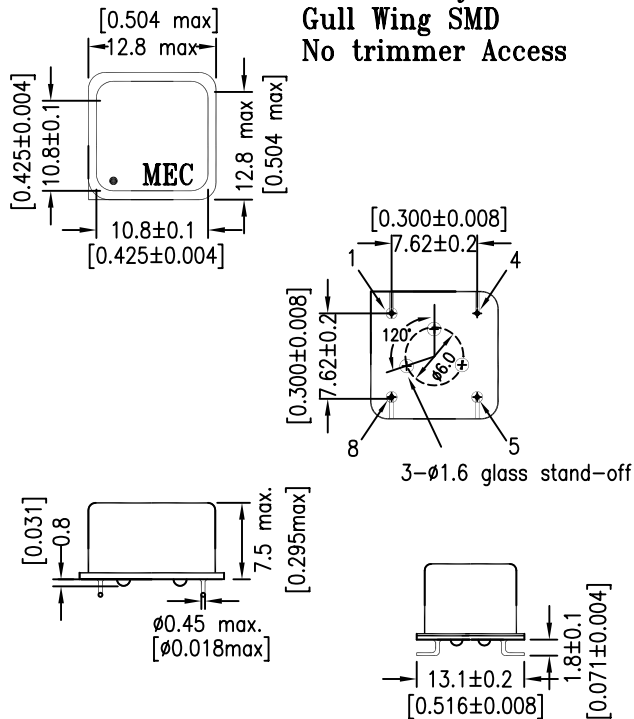

Pin Connections

Square corner denotes pin 1

- Pin 1: Voltage Control for VCTCXO or No Connection for TCXO
- Pin 4: Ground and case
- Pin 5: Output
- Pin 8: Supply Voltage

Package: M29K,VM29K

Sealed bottom
Gull Wing SMD

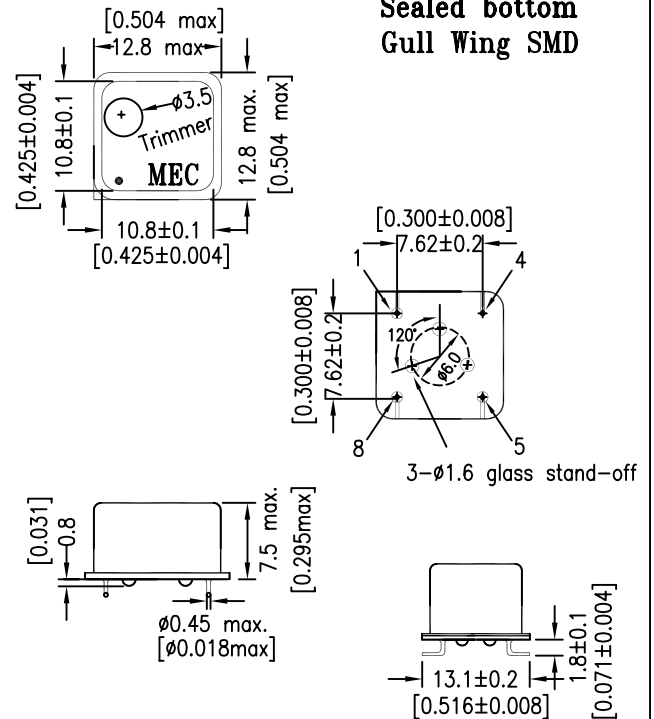

Pin Connections

Square corner denotes pin 1

- Pin 1: Voltage Control for VCTCXO or No Connection for TCXO
- Pin 4: Ground and case
- Pin 5: Output
- Pin 8: Supply Voltage

Package: M42K,VM42K

FR4 substrate

"42" represents 4 pads and 2.5 mm overall height

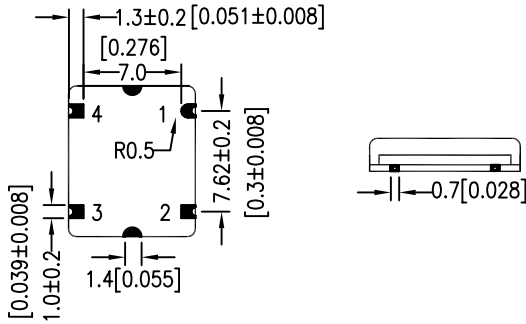
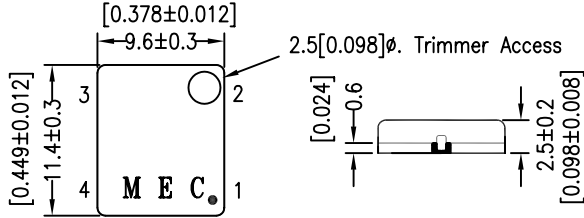

Pad Connections:

- Pad 1: Voltage Control for VCTCXO; No Connection for TCXO
- Pad 2: Ground and case
- Pad 3: Output
- Pad 4: Supply Voltage

Package: M62K,VM62K

FR4 substrate

"62" represents 6 pads and 2.5 mm overall height

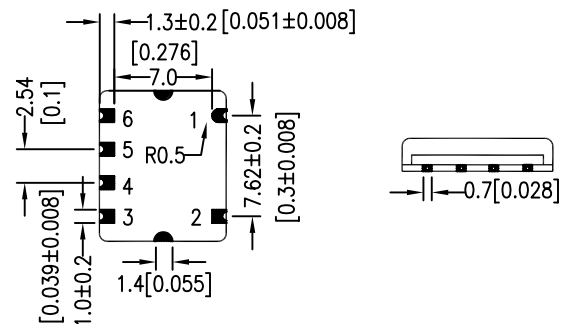
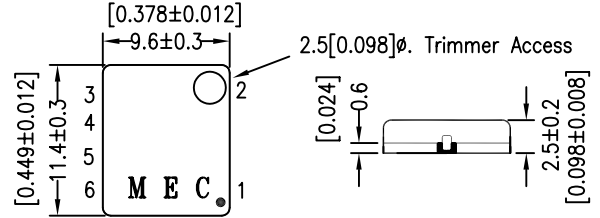

Pad Connections:

- Pad 1,2,4: Ground and case
- Pad 3: Output
- Pad 5: Voltage Control for VCTCXO; No Connection for TCXO
- Pad 6: Supply Voltage

Package: M44K,VM44K

FR4 substrate

"44" represents 4 pads and 4.7 mm overall height

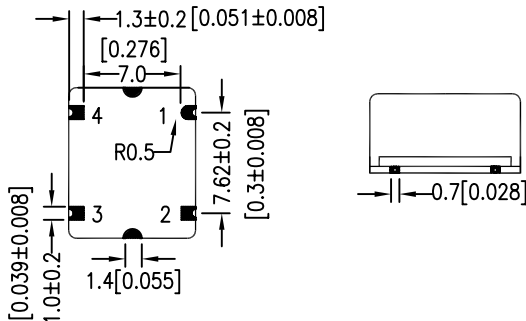
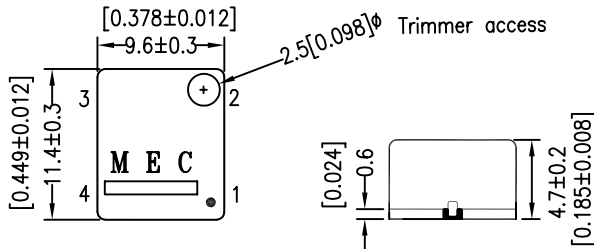

Pad Connections:

- Pad 1: Voltage Control for VCTCXO; No Connection for TCXO
- Pad 2: Ground and case
- Pad 3: Output
- Pad 4: Supply Voltage

Package: M64K,VM64K

FR4 substrate

"64" represents 6 pads and 4.7 mm overall height

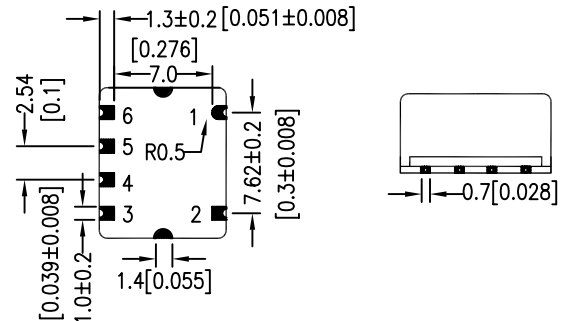
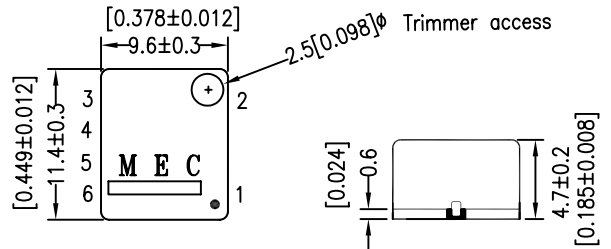

Pad Connections:

- Pad 1,2,4: Ground and case
- Pad 3: Output
- Pad 5: Voltage Control for VCTCXO; No Connection for TCXO
- Pad 6: Supply Voltage

TCXO;VCTCXO

Package: M57K,VM57K

Ceramic SMD

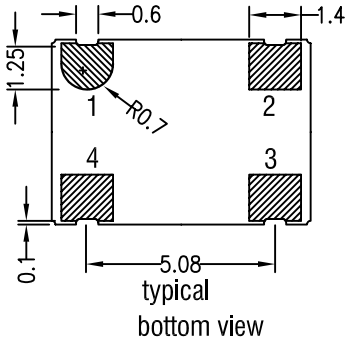
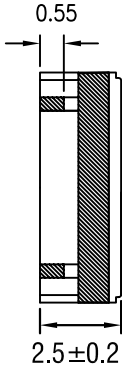
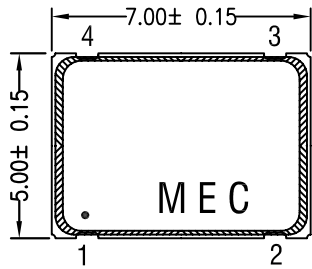

Pad Connections:

- Pad 1: "Do not connect" for TCXO; Voltage Control for VCTCXO
- Pad 2: Ground and metal lid
- Pad 3: Output
- Pad 4: Supply Voltage

Package: M53K,VM53K

Ceramic SMD

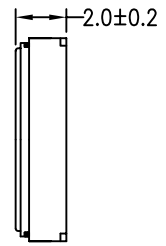
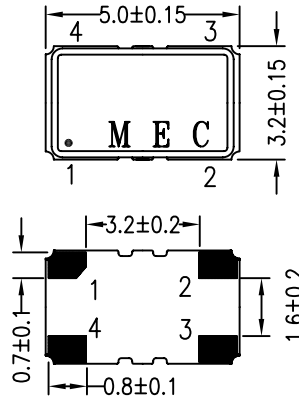

Pad Connections:

- Pad 1: "Do not connect" for TCXO; Voltage Control for VCTCXO
- Pad 2: Ground and metal lid
- Pad 3: Output
- Pad 4: Supply Voltage

TCXO;VCTCXO