

# Low EMI Spread Spectrum Clock Oscillators

3HM53 Group "R"

A DROP-IN REPLACEMENT SOLUTION FOR YOUR EMI / EMC COMPLIANCE PROBLEM

The principle sources of the EMI problem come from the system clocks. Therefore, rather than patch the problem with ferrite beads, EMI filters, ground plane and metal shielding, the most efficient and economic way to reduce the peak radiation energy is to use the low EMI clock oscillator.

Compared with the conventional clock oscillators, Mercury HM53 series spread spectrum (dithered) clock oscillators can reduce EMI as much as 12 dB. The beauty is it is a drop-in replacement for your existing 5x7 clock oscillator. No need to re-spin the board.

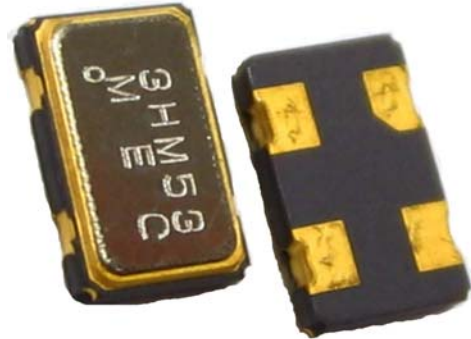

**3HM53 reduces your EMI and shorten your time to market.**

## Applications

- Printers; Multiple function printers (MPCs)
- Digital copiers; PDAs
- Networking; LAN / WAN; Routers
- Storage systems (CD-ROM, VCD, DVD and HDD)
- Scanner; Modems; projectors
- Hand-held ID readers
- Embedded systems; Electrical musical instrument
- Automotive; GPS car navigation systems
- LCD PC monitors / LCD TVs
- ADSL; PCMCIA
- Still Digital cameras (SDCs)

## Modulation Types

 Output amplitude (dB) vs frequency span (MHz)

Down spread "D". "D1" as an example

Center spread "C". "C0.5" as an example

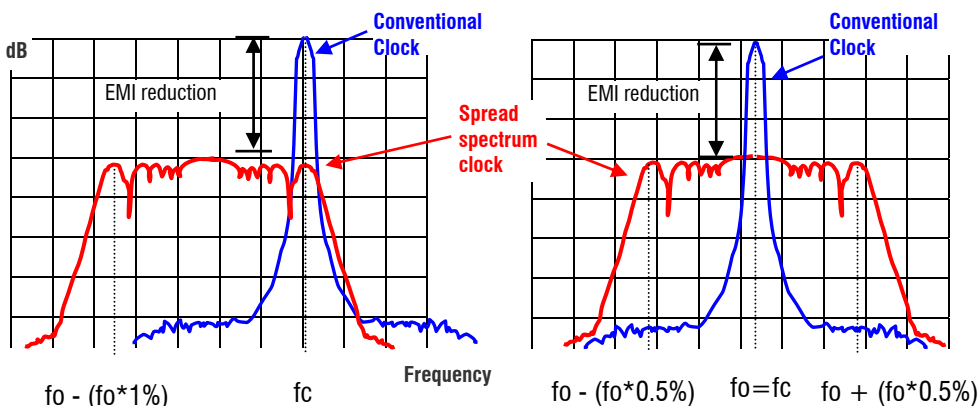

### Spread Spectrum Clock (SSC):

Unlike the conventional clock, the mode energy of a spread spectrum clock is spread over a wider bandwidth, resulting from the **frequency modulation** technique. The modulation carrier frequency is in the KHz range which makes the modulation process transparent to the oscillator frequency. The controlled modulation process can be on all of one side of the nominal frequency (**down spread**) or 50% up and 50% down (**center spread**). The down spread is preferred if **over-clocking** is a problem to the system.

MERCURY [www.mercury-crystal.com](http://www.mercury-crystal.com)



Taiwan: TEL (886)-2-2406-2779, FAX (886)-2-2496-0769, e-mail: [sales-tw@mercury-crystal.com](mailto:sales-tw@mercury-crystal.com)  
U.S.A.: TEL (1)-909-466-0427, FAX (1)-909-466-0762, e-mail: [sales-us@mercury-crystal.com](mailto:sales-us@mercury-crystal.com)

**General Specifications:** at Ta= +25°C, CL= 15 pF

<b>Mercury Model</b>	<b>3HM53 Group "R"</b>		
<b>Frequency Range</b>	6.0 ~160.0 MHz		
<b>Spread Type</b>	Total %	<b>Down Spread (D)</b>	<b>Center Spread (C)</b>
<b>Spread Percentage</b> (Part number suffix) (tolerance : ±2% of the total %)	1%	-1% (D1)	±0.5 (C0.5)
	3%	-3% (D3)	±1.5 (C1.5)
<b>EMI Reduction</b> (Reduction is applied to the entire spectrum)	-9 dBc min. 100 MHz at C0.5 -15 dBc min. 100 MHz at C1.5 With respect to the dB level when no modulation.		
<b>Modulation Carrier Frequency (Dither rate)</b>	6.9 KHz min.; 55.5 KHz max.; Frequency dependent. Call for details.		
<b>Output Logic</b>	CMOS Square Wave		
<b>Input Voltage (VDD)</b>	VDD = +3.3 V D.C. ±5%		
<b>Frequency Stability</b> (exclude modulation)	<b>Commercial</b> (0°C to +70°C): "A": ±25 ppm ; "B": ±50 ppm; "C": ±100 ppm		
	<b>Industrial</b> (-40°C to +85°C): "D": ±25 ppm ; "E": ±50 ppm; "F": ±100 ppm		
<b>Output Voltage "High"; "1"</b>	2.0 V min.; 3.2 V typical (at 90% VDD)		
<b>Output Voltage "Low"; "0"</b>	0.8 V max. ; 0.2 V typical (at 10% VDD)		
<b>Rise Time / Fall Time</b>	4 n sec. max. (10% VDD ↔ 90% VDD)		
<b>Load</b>	15 pF		
<b>Start-up Time</b>	2 ms typical; 5 ms max.		
<b>Stabilization Time</b>	2 ms max.		
<b>Current Consumption</b>	10.0 MHz: 7 mA; 32.768 MHz: 8 mA 75.0 MHz: 17 mA; 125 MHz: 18 mA		
<b>Duty Cycle</b>	50%±5%. ( CL= 15 pF ;at 50% VDD)		
<b>Cycle-to-cycle Jitter</b>	±250 ps typical; ±300 ps max.		
<b>Output Impedance</b>	40 ohms typical		
<b>Static Discharge Voltage</b>	>2000 V (per MIL-STD-883, method 3015)		
<b>Storage Temperature</b>	-65°C to +150°C		
<b>Aging</b>	±5 ppm per year max.; Ta= +25°C		
<b>Packaging</b>	16 mm tape and reel. 1000 pcs per reel		
<b>Pin 1 Function</b>	Output is high impedance when taken low. Output enable /disable time: 100 ns max.		

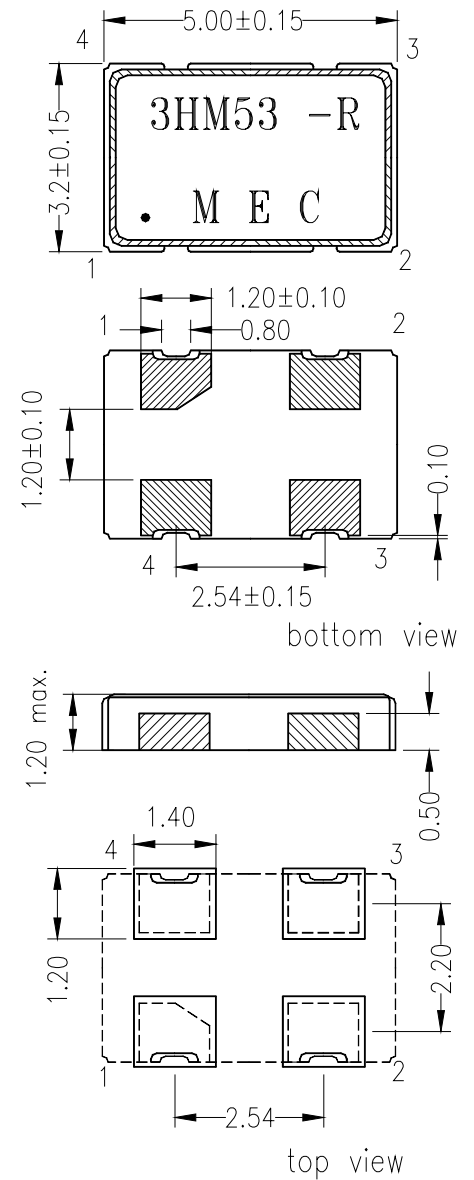

Pad Connections			
1	Tri-State	3	SSC Output
2	Ground	4	+3.3 V D.C.

**Environmental Performance Specifications**

Green Requirement	RoHS Compliant and Pb (lead) free
Storage temp. range	-55 to +125°C
Humidity	85% RH, 85°C, 48 hours
Hermetic seal	Leak rate 2x10 <sup>-8</sup> ATM-cm <sup>3</sup> /sec max.
Solderability	MIL-STD-202F method 208E
Reflow	260°C for 10 sec.
Vibration	MIL-STD-202F method 204, 35G, 50 to 2000 Hz
Shock	MIL-STD-202F method 213B, test condition. E, 1000GG ½ sine wave

**How to Order: Part number Example**

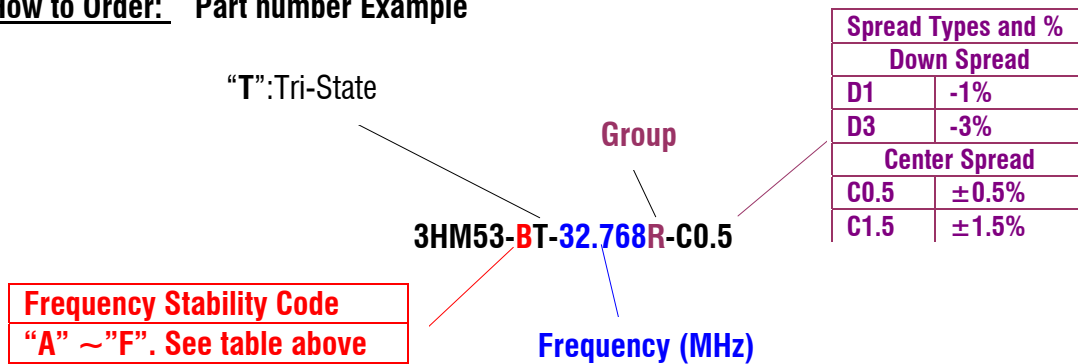

**Other Packages Available:**

- HM57: 5x7x1.8 mm 4 pad ceramic SMDs
  - HM14: Full size 4 pin DIPs
  - HM8: Half size 4 pin DIPs
  - HM42: 9.6x11.4x2.5 mm FR4 base leadless SMDs
  - HM44: 9.6x11.4x4.7 mm FR4 base leadless SMDs
- Please visit [www.mercury-crystal.com](http://www.mercury-crystal.com)

**Instantaneous Frequencies (Example of 100 MHz)**

If over-clocking is a problem to your system please choose down spread

Total Spread %	Down Spread Instantaneous Frequency		Center Spread Instantaneous Frequency	
	min.	max.	min.	max.
	Down Range	Up Range	Down Range	Up Range
1 %	- 1%	0%	-0.5 %	+0.5%
	-10,000 ppm	0 ppm	-5000 ppm	+5000 ppm
	<b>99.000000</b>	<b>100.000000</b>	<b>99.500000</b>	<b>100.500000</b>
3 %	- 3.0%	0%	-1.5 %	+1.5%
	-30,000 ppm	0 ppm	-15,000 ppm	+15,000 ppm
	<b>97.000000</b>	<b>100.000000</b>	<b>98.500000</b>	<b>101.500000</b>

**3HM53-32.768 at No Modulation and at Center Spread 1.5%: 13.1 dBc EMI reduction**

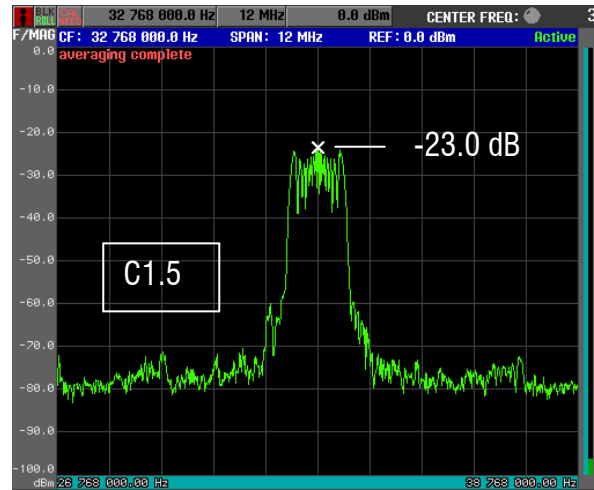
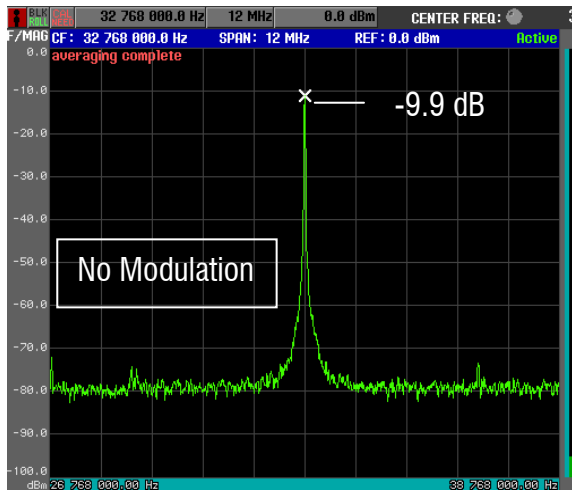

**EMI Reduction of 3HM53 100 MHz at C0.5 and C1.5 (main mode only)**

**Modulation Carrier Frequency = 34.687 KHz**

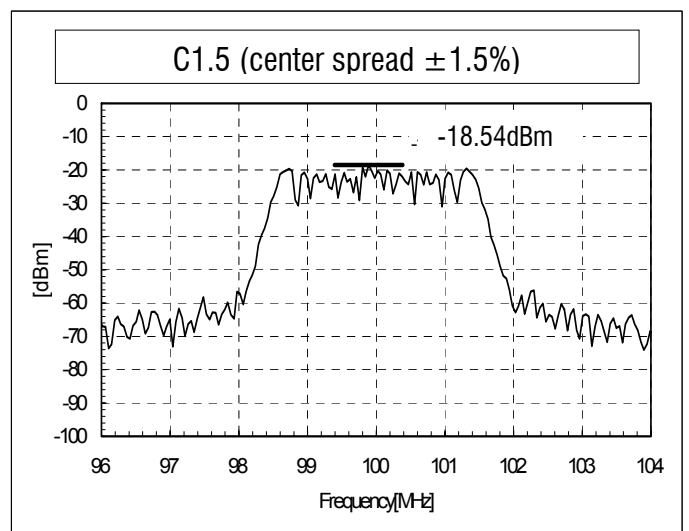
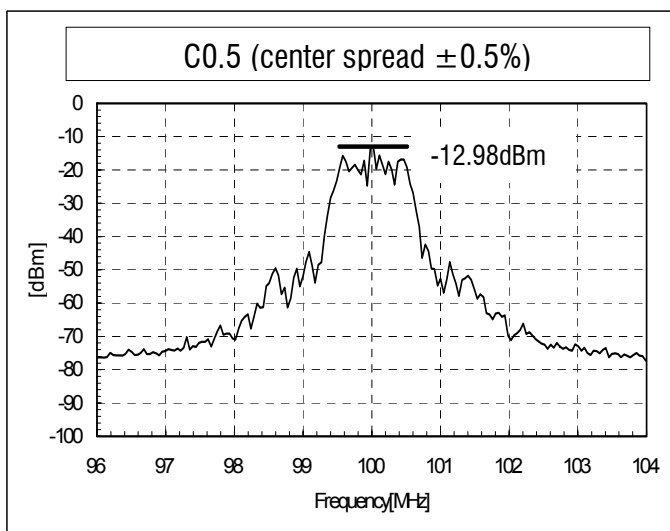
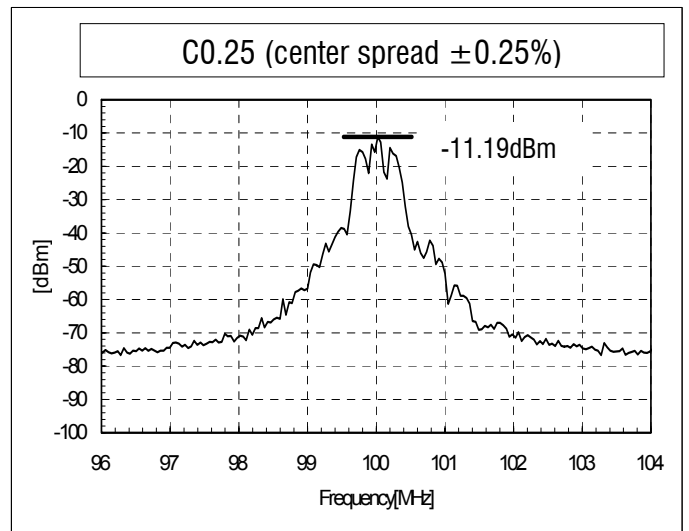
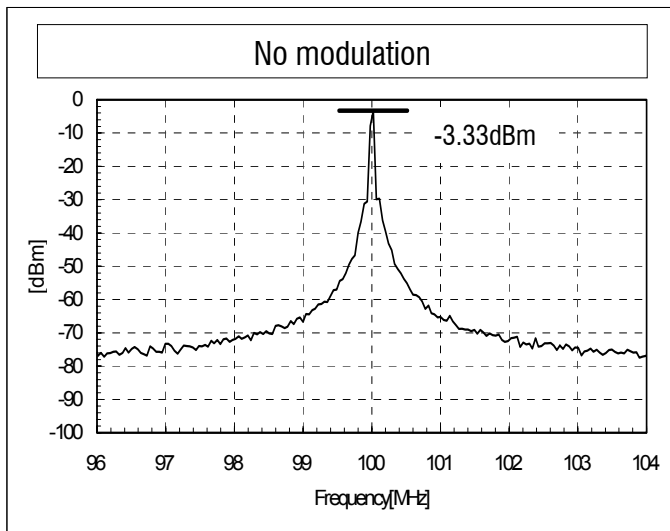

**EMI Reduction of 3HM53 100 MHz at C0.5 and C1.5 (the whole spectrum)**

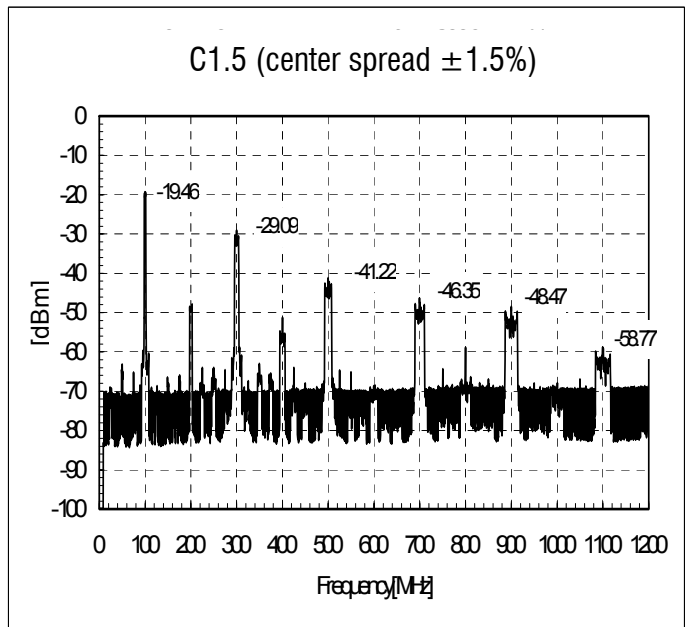
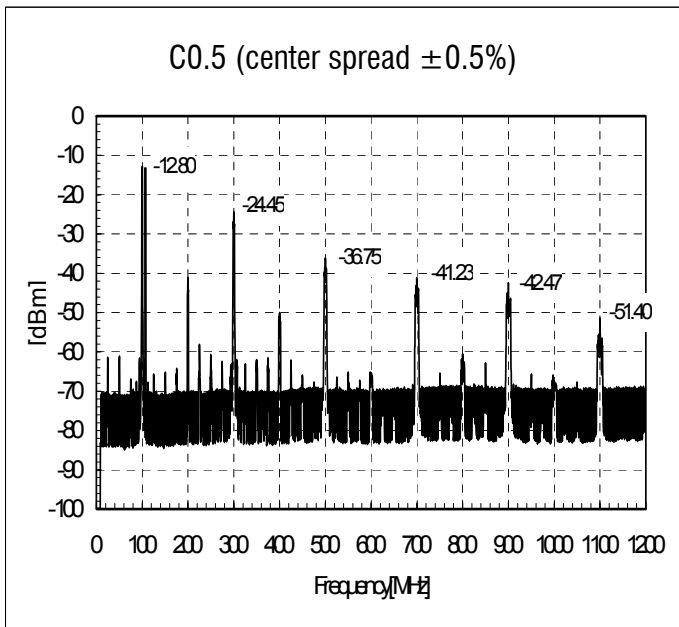
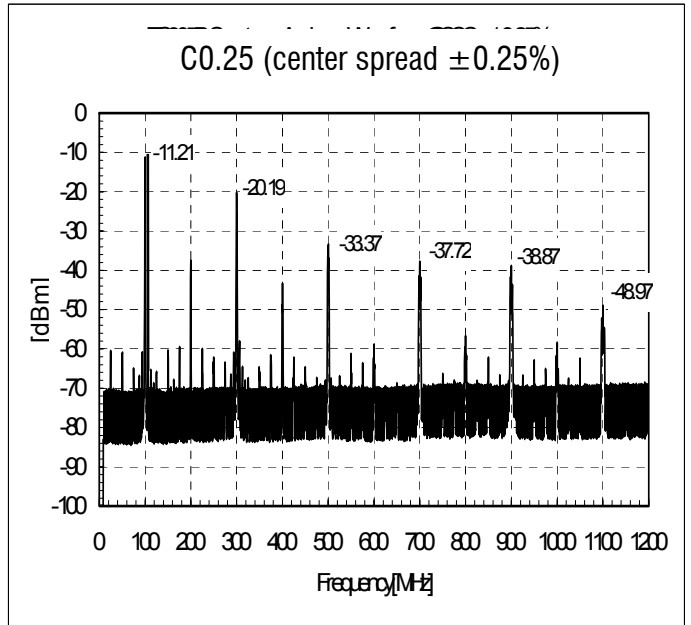
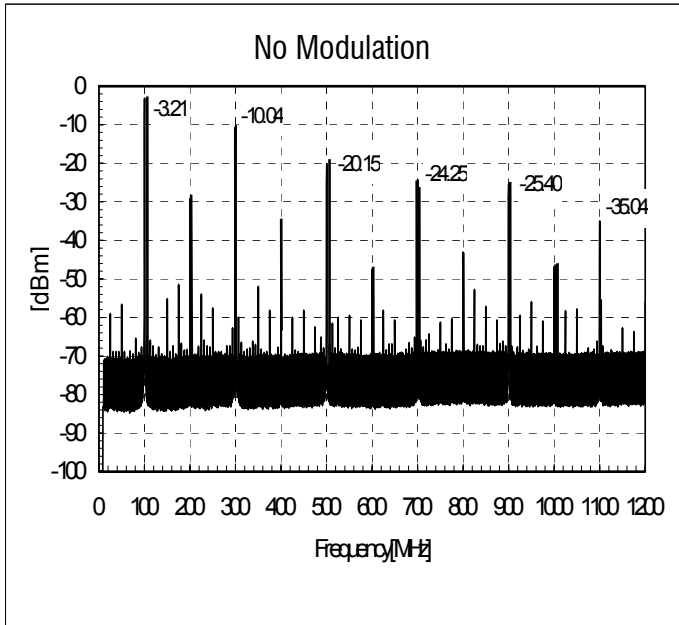

For more technical information please visit [www.mercury-crystal.com](http://www.mercury-crystal.com) and download our technical note TN-020 (Title: “**Low EMI Spread Spectrum Clock Oscillators**”).